

---

# GUIDELINES FOR GEOLOGIC HAZARD CHARACTERIZATION OF TRANSPORTATION CORRIDORS

---

Association of Environmental and Engineering Geologists Special Publication #32

---



Authors:

Arun Parsons  
Andrew Graber  
Kyle Radach  
Lindsey Margolies  
Jacquelyn Hagberry  
Jerry Higgins  
Marilyn Dodson  
Paul Santi ([psanti@mines.edu](mailto:psanti@mines.edu), corresponding author)

## **Author Affiliations**

All authors were affiliated with Colorado School of Mines at the time of writing, with the exception of Dodson, who is affiliated with the Federal Highway Administration.

## **Cover Figure**

U.S. Highway 24 Business / Manitou Avenue, Manitou Springs Colorado. Road damage from landslide due to uncontrolled rainfall runoff, 2013 flood event.

## **Acknowledgements**

The Federal Highway Administration sponsored this study, for which we are very grateful. This document is published with their permission.

The contents of this report reflect the views of the authors, who are responsible for the facts and accuracy of the data presented herein.

The contents do not necessarily reflect policy of the Department of Transportation. This report does not constitute a standard, specification, or regulation.

The United States Government does not endorse products or manufacturers. Trademarks or manufacturer's names appear in this report only because they are considered essential to the objective of this document.

Published by the Association of Environmental and Engineering Geologists

ISBN 978-09897253-8-5

**January 2025**

## SI\* (MODERN METRIC) CONVERSION FACTORS

### APPROXIMATE CONVERSIONS TO SI UNITS

Symbol	When You Know	Multiply By	To Find	Symbol
<b>LENGTH</b>				
in	inches	25.4	millimeters	mm
ft	feet	0.305	meters	m
yd	yards	0.914	meters	m
mi	miles	1.61	kilometers	km
<b>AREA</b>				
in <sup>2</sup>	square inches	645.2	square millimeters	mm <sup>2</sup>
ft <sup>2</sup>	square feet	0.093	square meters	m <sup>2</sup>
yd <sup>2</sup>	square yard	0.836	square meters	m <sup>2</sup>
ac	acres	0.405	hectares	ha
mi <sup>2</sup>	square miles	2.59	square kilometers	km <sup>2</sup>
<b>VOLUME</b>				
fl oz	fluid ounces	29.57	milliliters	mL
gal	gallons	3.785	liters	L
ft <sup>3</sup>	cubic feet	0.028	cubic meters	m <sup>3</sup>
yd <sup>3</sup>	cubic yards	0.765	cubic meters	m <sup>3</sup>
NOTE: volumes greater than 1000 L shall be shown in m <sup>3</sup>				
<b>MASS</b>				
oz	ounces	28.35	grams	g
lb	pounds	0.454	kilograms	kg
T	short tons (2000 lb)	0.907	megagrams (or "metric ton")	Mg (or "t")
<b>TEMPERATURE (exact degrees)</b>				
°F	Fahrenheit	5 (F-32)/9 or (F-32)/1.8	Celsius	°C
<b>ILLUMINATION</b>				
fc	foot-candles	10.76	lux	lx
fl	foot-Lamberts	3.426	candela/m <sup>2</sup>	cd/m <sup>2</sup>
<b>FORCE and PRESSURE or STRESS</b>				
lbf	poundforce	4.45	newtons	N
lbf/in <sup>2</sup>	poundforce per square inch	6.89	kilopascals	kPa

### APPROXIMATE CONVERSIONS FROM SI UNITS

Symbol	When You Know	Multiply By	To Find	Symbol
<b>LENGTH</b>				
mm	millimeters	0.039	inches	in
m	meters	3.28	feet	ft
m	meters	1.09	yards	yd
km	kilometers	0.621	miles	mi
<b>AREA</b>				
mm <sup>2</sup>	square millimeters	0.0016	square inches	in <sup>2</sup>
m <sup>2</sup>	square meters	10.764	square feet	ft <sup>2</sup>
m <sup>2</sup>	square meters	1.195	square yards	yd <sup>2</sup>
ha	hectares	2.47	acres	ac
km <sup>2</sup>	square kilometers	0.386	square miles	mi <sup>2</sup>
<b>VOLUME</b>				
mL	milliliters	0.034	fluid ounces	fl oz
L	liters	0.264	gallons	gal
m <sup>3</sup>	cubic meters	35.314	cubic feet	ft <sup>3</sup>
m <sup>3</sup>	cubic meters	1.307	cubic yards	yd <sup>3</sup>
<b>MASS</b>				
g	grams	0.035	ounces	oz
kg	kilograms	2.202	pounds	lb
Mg (or "t")	megagrams (or "metric ton")	1.103	short tons (2000 lb)	T
<b>TEMPERATURE (exact degrees)</b>				
°C	Celsius	1.8C+32	Fahrenheit	°F
<b>ILLUMINATION</b>				
lx	lux	0.0929	foot-candles	fc
cd/m <sup>2</sup>	candela/m <sup>2</sup>	0.2919	foot-Lamberts	fl
<b>FORCE and PRESSURE or STRESS</b>				
N	newtons	0.225	poundforce	lbf
kPa	kilopascals	0.145	poundforce per square inch	lbf/in <sup>2</sup>

## TABLE OF CONTENTS

LIST OF FIGURES .....	iii
LIST OF TABLES .....	v
PREFACE: HOW TO USE THIS DOCUMENT .....	vi
SECTION 1. INTRODUCTION .....	1
1.1 INTRODUCTION .....	2
1.2 CONCEPTUAL DEVELOPMENT .....	2
1.3 SYSTEM OVERVIEW .....	4
1.4 OUTCOMES .....	7
1.5 LIMITATIONS .....	10
1.6 SELECTED WIDELY APPLICABLE REFERENCES.....	10
SECTION 2. IDENTIFICATION OF POTENTIAL GEOLOGIC HAZARDS.....	11
2.1 REVIEW OF REQUIRED INFORMATION .....	12
2.1.1 Bedrock Information .....	16
2.1.2 Surficial Materials Information .....	17
2.1.3 Topography and Geomorphology Information .....	18
2.1.4 Location Information .....	19
2.1.5 Climate Information .....	21
2.2 FLOWCHARTS TO IDENTIFY POTENTIAL GEOLOGIC HAZARDS .....	22
2.2.1 Bedrock Flowchart .....	23
2.2.2 Surficial Materials Flowchart .....	24
2.2.3 Topography and Geomorphology Flowchart .....	25
2.2.4 Location Flowchart .....	26
2.2.5 Climate Flowchart .....	27
SECTION 3. GUIDELINES FOR GEOLOGIC HAZARD INVESTIGATION AND CHARACTERIZATION .....	28
3.1 EXPANSIVE CLAY SOILS AND BEDROCK .....	29
3.2 HEAVING BEDROCK .....	34
3.3 EXPANSIVE ALKALI SOILS .....	39
3.4 FROST ACTION .....	43
3.5 CARBONATE KARST .....	49
3.6 EVAPORITE KARST .....	59
3.7 SUBSIDENCE DUE TO UNDERGROUND MINING .....	65
3.8 SUBSIDENCE DUE TO FLUID WITHDRAWAL .....	71



3.9	COLLAPSIBLE SOILS .....	79
3.10	ORGANIC SOILS AND PEAT .....	87
3.11	SENSITIVE CLAYS .....	91
3.12	PERMAFROST .....	95
3.13	SALINE SOILS .....	103
3.14	GYPSIFEROUS SOILS .....	108
3.15	SULFATE SOILS .....	112
3.16	ACID SULFATE SOILS .....	117
3.17	SULFIDE ROCK .....	122
3.18	SULFIDE MINE TAILINGS .....	127
3.19	UNSTABLE ROCK SLOPES .....	131
3.20	UNSTABLE SOIL SLOPES .....	143
3.21	UNSTABLE SLOPES IN SHALE, CLAYSTONE AND OTHER DEGRADABLE SEDIMENTARY ROCKS .....	157
3.22	TALUS .....	164
3.23	SEISMIC HAZARDS .....	168
3.24	ACTIVE VOLCANIC HAZARDS .....	177
3.25	VOLCANIC TERRAIN HAZARDS .....	186
3.26	SURFACE WATER HAZARDS .....	193
3.27	COASTAL HAZARDS .....	201
3.28	NATURALLY OCCURRING ASBESTOS .....	212
3.29	WILDFIRE BURN AREAS .....	217
APPENDIX	Spreadsheet of Causative and Associative Factors .....	224

## LIST OF FIGURES

1-1	Diagram. Conceptual model for the identification of geologic hazards at a given location, following a two-stage process . . . . .	3
1-2	Diagram. The five-step process devised to facilitate the identification and characterization of geologic hazards at a given location . . . . .	4
3-1	Schematic. Block diagram of swelling clay soils . . . . .	30
3-2	Schematic. Block diagram of heaving bedrock, symmetrical heave features . . . . .	35
3-3	Schematic. Block diagram of heaving bedrock, asymmetrical heave features . . . . .	35
3-4	Schematic. Example trench log from an area prone to heaving bedrock near Denver, CO . . . . .	36
3-5	Schematic. Subsurface conditions associated with frost heave . . . . .	44
3-6	Chart. Frost susceptibility classification and expected average rate of heave, based upon particle size distribution and soil type . . . . .	47
3-7	Schematic. Cross section through limestone showing underground drainage, sinkholes and pinnacled rockhead . . . . .	50
3-8	Schematic. Cross section of sinkholes showing both gradual and sudden subsidence . . . . .	51
3-9	Photo. Surface collapse of cohesive soils above a sinkhole in Winter Park, Florida . . . . .	51
3-10	Photo. Pinnacled rockhead . . . . .	52
3-11	Photo. Cave beneath a construction site near Springfield, Missouri . . . . .	52
3-12	Photo. Solution features exposed during earthworks for the Clarence Cannon Dam, central Missouri . . . . .	52
3-13	Schematic. Cross section of exploratory borings in highly developed karst in Kuala Lumpur, Malaysia . . . . .	54
3-14	Chart. Cave stability related to cave width and rock mass quality . . . . .	56
3-15	Schematic. Cross sections through evaporite bedrock and soil cover showing the progressive formation of a sinkhole . . . . .	58
3-16	Schematic. Cross sections through evaporite bedrock illustrating the progressive formation of a breccia pipe . . . . .	60
3-17	Photo. Surface collapse features above evaporite sinkholes near Glenwood Springs, CO . . . . .	60
3-18	Schematic. Cross section of an advancing longwall faces . . . . .	66
3-19	Satellite photo. Room and pillar mine subsidence near Sheridan, Wyoming . . . . .	66
3-20	Map. Regions where land subsidence has been attributed to groundwater extraction, and areas underlain by major alluvial aquifers in the United States . . . . .	71
3-21	Schematic. Cross section illustrating cyclic compaction and rebound of a sandy aquifer due to seasonal fluctuations in groundwater levels . . . . .	72
3-22	Schematic. Cross section illustrating irreversible compaction of clay-rich aquitards due to long-term groundwater extraction . . . . .	73
3-23	Graph. Specific storage for non-recoverable compaction as a function of depth . . . . .	77

3-24	Charts. Examples of empirical relationships between soil properties and soil collapse . . . . .	83
3-25	Map. Occurrence of permafrost in Alaska . . . . .	96
3-26	Schematic. North south cross-section showing variation of permafrost thickness and continuity with latitude . . . . .	96
3-27	Schematic. Block diagrams of typical soil profiles in permafrost . . . . .	97
3-28	Schematic. Cross section of a typical thermal regime in a permafrost region . . . . .	100
3-29	Schematic. Simple structurally-controlled failures of rock slopes . . . . .	133
3-30	Schematic. Complex structurally-controlled failures of rock slopes . . . . .	133
3-31	Photographs. Environmentally-controlled failures of rock slopes . . . . .	134
3-32	Schematic. Slope profile identifying possible source, launch, impact and run-out zones . . . . .	140
3-33	Schematic. Block diagrams of morphologic changes with time of an idealized rotational slide in a humid climate . . . . .	144
3-34	Block diagrams of morphologic changes with time of an idealized rotational slide in an arid or semi-arid climate . . . . .	145
3-35	Schematic. Cross-sectional and block diagrams of movement types on soil slopes . . . . .	147
3-36	Photo. Talus slope and talus cones . . . . .	164
3-37	Schematic. Cross section through three classes of talus . . . . .	165
3-38	Map. Peak ground acceleration for a 10% probability of exceedance in 50 years . . . . .	169
3-39	Map. Volcanoes located in the western U.S. and its territories . . . . .	178
3-40	Photo. Photograph of pyroclastic flow traveling down the flanks of Mt. St Helens during the August 7, 1980 eruption, viewed from a vantage point 5 miles north of Mt. St. Helens on Johnston Ridge . . . . .	181
3-41	Schematic. Diagram of littoral drift process and terminology . . . . .	203

## LIST OF TABLES

1-1	Summary table of flowchart outcomes . . . . .	9
2-1	Required information and its sources . . . . .	13-15
3-1	Approximate height of capillary rise for broadly classified soil groups . . . . .	46
3-2	Severity Criteria for soil collapse with test load of 4,200 psf . . . . .	82
3-3	Hazard Criteria for soil collapse with test load of 1,000 psf . . . . .	82
3-4	Dispersivity classifications that may be applied to the crumb test . . . . .	84
3-5	Dispersivity classifications that may be applied to the double hydrometer test . . . . .	84
3-6	Properties and classification of organic soils and peat . . . . .	89
3-7	Classification of soil by sensitivity . . . . .	93
3-8	Effect of soil-resistivity on corrosion of metal . . . . .	106
3-9	Classification of severity of sulfate environment based upon concentration of water-soluble sulfates . . . . .	115
3-10	Guidelines for recommended lime-treatment of soils based upon concentration of water-soluble sulfates . . . . .	115
3-11	Some parameters of interest when investigating current movements on rock slopes, and the instrumentation that may be used to monitor them . . . . .	137
3-12	Abbreviated classification of slope movements . . . . .	146
3-13	Glossary for forming names of slope movements . . . . .	146
3-14	Key to landforms and their susceptibility to landslides . . . . .	151
3-15	Some parameters of interest when investigating current movements on soil slopes, and the instrumentation that may be used to monitor them . . . . .	152
3-16	Site class definitions specified by AASHTO for seismic design of bridges . . . . .	172

## **PREFACE: HOW TO USE THIS DOCUMENT**

While it is recommended that geologic hazard identification and characterization be a preliminary step in engineering projects and land-use planning, the system presented here can be applied at any stage in the planning and design process. The procedure for utilizing the potential geologic hazard identification system, and the site investigation and hazard characterization guidelines is as follows:

- 1) Know the specific location of the site of interest.
- 2) Gather and review existing information of the site, as detailed in ‘Review of Existing Information’ (Section 2.1).
- 3) Use the information to navigate the five flowcharts (Section 2.2) and identify potential geologic hazards that may exist at the site.
- 4) For each potential hazard indicated by the flowcharts, review the relevant chapter of ‘Site Investigation Guidelines for Geologic Hazard Characterization’ (Section 3). Preliminary review of each chapter will provide an understanding of the occurrence and mechanism of the hazard, and list field indicators that can be identified during site reconnaissance.
- 5) Perform site reconnaissance. Try to verify the presence the potential hazards indicated by the flow charts. Look for field indicators, and use an understanding of the development and occurrence of each hazard to assess the likelihood of its existence at the site. At this stage it may be possible to discount some of the potential hazards. If there is uncertainty over the existence of a hazard it is advisable to conduct investigations as recommended.
- 6) Plan and implement site investigations, as recommended, to identify and characterize geologic hazards that might exist at the site.



## **SECTION 1**

### **INTRODUCTION**

## 1.1 INTRODUCTION

Transportation corridors are frequently located in complex geologic settings where unexpected geologic hazards may exist; either because of their rarity, or because they are beyond the previous experience of the engineers involved.

This guidance was developed for the identification and characterization of geologic hazards affecting transportation corridors. It is designed to be efficient and easy to use, taking the form of flowcharts, checklists and concise documentation. The aim is to identify, characterize and evaluate geologic hazards in the early stages of engineering projects, in order to facilitate better selection of alignment alternatives, expedite the design process and prevent costly change orders during construction.

The problematic effects of geologic hazards are not restricted to transportation corridors. Geologic hazards pose a threat to all kinds of engineered works, and are often a danger to human life. A system of hazard identification and characterization that could be implemented in the early stages of land-use planning and feasibility studies would be widely applicable and could potentially save money and lives. Previously, no single system has been developed to identify and characterize a wide range of geologic hazards. This document presents such a system.

## 1.2 CONCEPTUAL DEVELOPMENT

In order for a geologic hazard identification and characterization system to be of practical use it must, at the very least, possess the following three attributes. These requirements were a major influence on the conceptualization and development of this system. The system must be:

- Relatively simple and easy to use,
- Cost effective, and
- Usable by professionals not trained in geological engineering or geologic hazard assessment, as such professionals are very often required to make decisions about land use or site selection.

This system addresses twenty-nine types of hazards that are identifiable in the United States and may be encountered in transportation projects. A two-stage process is presented to narrow this list down to the hazards that potentially affect a given location. Figure 1-1 illustrates this two-stage process.

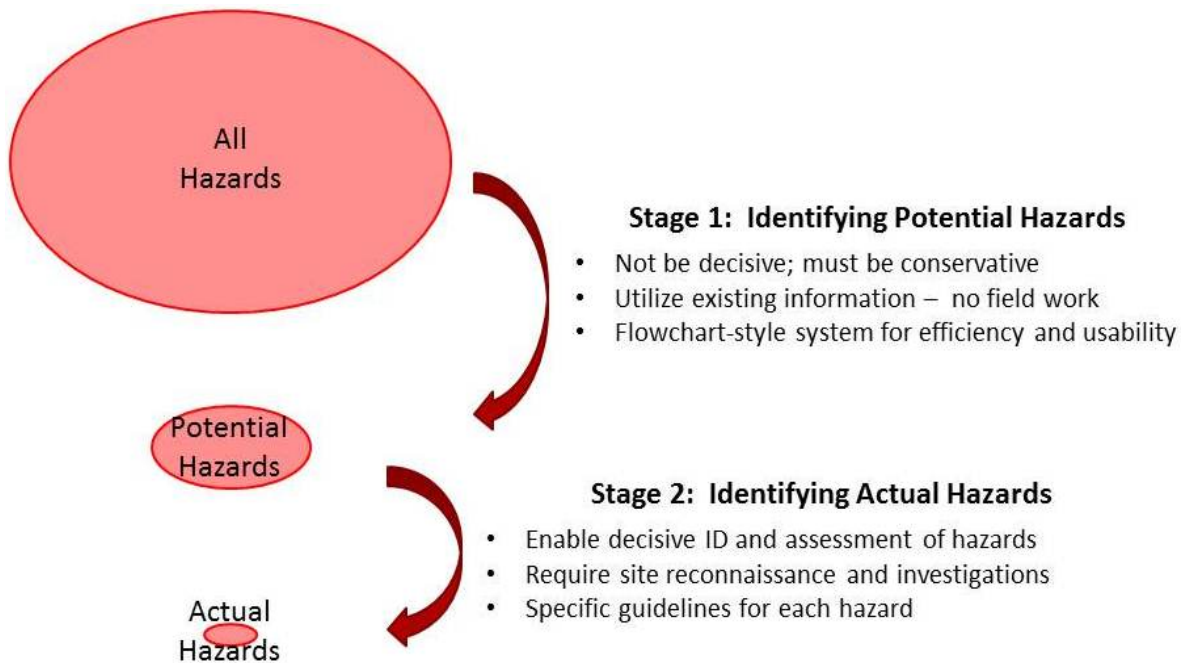
Stage 1 identifies potential hazards at the location of interest. This stage is intended to be conservative, in an effort to identify any hazards that could reasonably affect the location, so it likely indicates more hazards than actually exist at the location. Stage 1 is achieved using a flowchart-style system that requires only the use of existing information; no fieldwork is necessary. This type of procedure is efficient and cost-effective, providing the user with a list of potential hazards far reduced from the original list of possibilities.

Stage 2 identifies the actual hazards existing at the location, and allows for initial characterization of them. This stage is decisive, so as to allow judgements to be made regarding the ongoing project. This level of characterization requires site reconnaissance and

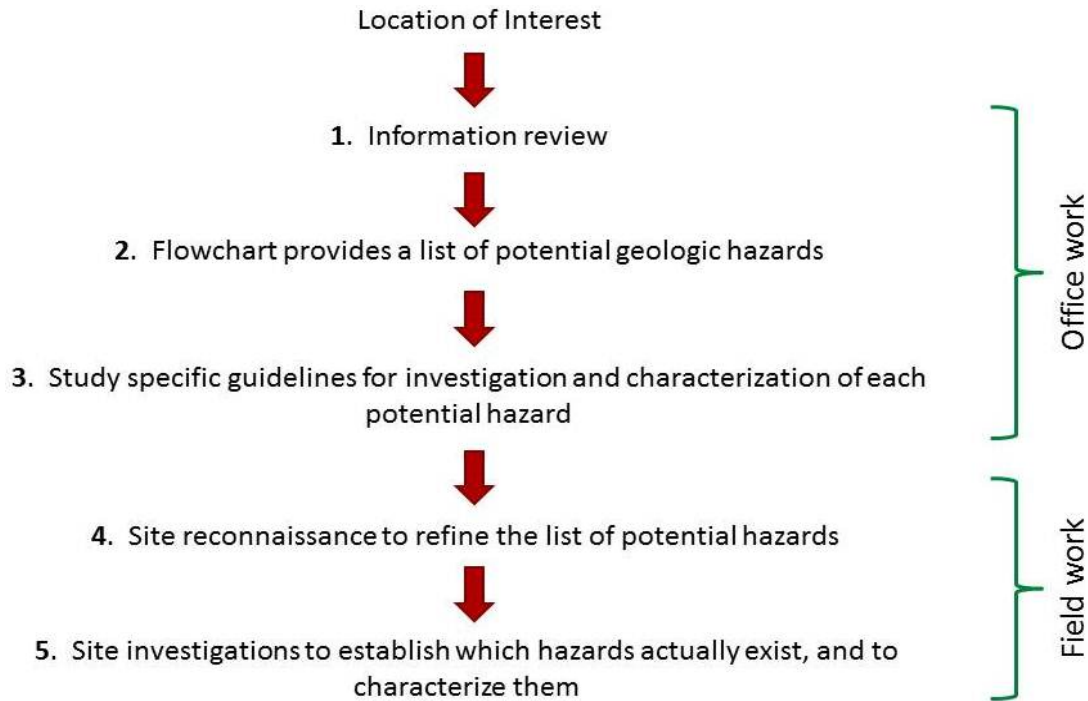
investigations, and Stage 2 chapters (Section 3) provide detailed, hazard-specific guidelines for site reconnaissance, site investigations and hazard characterization.

In practice, the concept described above is realized by a process involving five steps, as illustrated in Figure 1-2. With a specific location of interest, the user conducts research of existing information, as directed. The user applies the information to navigate a flowchart, which provides a list of geologic hazards that might potentially exist at the site. Use of the hazard-specific guidelines then enables the user to perform site reconnaissance and to plan and implement site investigations to effectively identify and characterize which geologic hazards actually exist at the location. The first three steps of this process (information review, flowchart navigation and guideline study) can generally be conducted in the office, prior to any site visits. The final two steps of this process (site reconnaissance and site investigations) require field work.

This process allows potential hazards to be recognized relatively quickly and cheaply. The process also produces background knowledge and understanding of the issue (geologic hazards to engineering works) before money is invested and resources are committed to identify and characterize actual hazards.



**Figure 1-1** Conceptual model for the identification of geologic hazards at a given location, following a two-stage process.



**Figure 1-2** The five-step process devised to facilitate the identification and characterization of geologic hazards at a given location, as conceptualized in Figure 1-1 above.

### 1.3 SYSTEM OVERVIEW

The system conceptualized in the previous section incorporates a list of information for navigating the flowchart, a flowchart system to identify potential geologic hazards, and hazard specific guidelines to definitively identify hazards at a given location. The flowchart system is explained first because the nature of the flowchart controls the information required to navigate it. The information list and hazard specific guidelines are explained last.

#### FLOWCHART SYSTEM

The prediction of geologic hazard occurrence requires knowledge and understanding of the factors that cause each hazard and the environmental conditions associated with each hazard. In this report, these are termed ‘causative factors’ and ‘associative factors’, respectively. The dominant causative and associative factors of geologic hazards included in the flowchart system are:

- Bedrock
- Surficial materials
- Topography and geomorphology
- Geographic location
- Climate
- Site history (in terms of previous land use)

Each one of these factors could be a causative factor, an associative factor, or both, depending upon the geologic hazard in question. For example; bedrock is a *causative* factor of heaving bedrock, but bedrock is an *associative* factor of expansive clay soils. While there is a distinct difference between what causes a hazard and what is associated with it, in the interests of hazard prediction both causative and associative factors may be equally important.

For a flowchart system to be effective, it must be ordered. The creation of the hazard identification flowchart required ordered information on the causative and associative factors of each hazard. This information was obtained through research of technical publications from the U.S. Department of Transportation (USDOT) and published material from the wider scientific community. The information was compiled in a spreadsheet, to allow for easy cross-reference and for the identification of patterns and order. The spreadsheet can be found in the Appendix.

Study of the spreadsheet quickly shows that ‘site history’ is only an important factor in a minority of geologic hazards. Due to the low influence of site history, this factor was discounted from the identification system at this point. Each of the five other factors are shown to be closely associated with a considerable number of hazards, but no factor alone is closely associated with all hazards. This implies that, while site history can be discounted because it does not help distinguish or identify hazards, the other factors are useful tools in the identification of hazards. Another important aspect of the spreadsheet is that the majority of hazards are only associated with two or three factors. This implies that, if the flowchart ‘decisions’ are chosen carefully, most hazards can be identified with just two or three steps.

The relationships between geologic hazards and their causative and associative factors implies that five separate flowcharts, each starting from a different factor, are more efficient and practical than a single flowchart. As described above, each hazard can potentially be identified with just two or three steps *if one started from the right point*. This efficiency is harnessed by separate flowcharts that allow for different ‘entry points’ into the system. Since each individual flowchart requires only two or three stages to distinguish among a select group of hazards, each of these flowcharts is relatively compact. Smaller flowcharts are easier to publish, more portable and easier to use.

Five flowcharts were created, each starting from one of the five causative factors; bedrock, surficial materials, topography and geomorphology, location, and climate. Each factor is related to only a fraction of geologic hazards, thus on each flowchart only a fraction of hazards are potential outcomes. To distinguish between the hazards for each factor requires only one or two well-chosen ‘qualifications’. Therefore, in the interest of conservancy, a qualifying factor was only incorporated if it was conclusively indicative of the hazard’s existence.

## **REQUIRED INFORMATION**

The information required to navigate the flowcharts was compiled by studying the flowcharts themselves. Effort was made to simplify and reduce the list as much as possible, and there were occasions where a flowchart was modified to make it navigable with information that is more readily available.



## **HAZARD-SPECIFIC GUIDELINES FOR GEOLOGIC HAZARD INVESTIGATION AND CHARACTERIZATION**

The guidelines for investigation and characterization were compiled through research of technical publications from the U.S. Department of Transportation (USDOT) and published material from the wider scientific community.

Each geologic hazard requires unique procedures for its site investigation and characterization, thus each hazard merited an individual set of guidelines. This part of the system is formatted to present each set of guidelines as a discreet chapter. Chapters were organized to be mindful of the target audience, ease of use, efficiency and cost.

### **The Target Audience:**

This system is intended for use by technical professionals with no pre-existing specialist knowledge of geologic hazards. To provide the user with useful background, the guidelines include concise explanations of the mechanisms of development and the manifestation of each geologic hazard, as well as references for further reading. However, many projects may eventually require the input of technical professionals who are experienced with particular hazards to facilitate adequate and efficient characterization and mitigation. Generally, detailed site investigation and mitigation design are the steps most likely to require additional expertise. Ultimately, when to seek additional expertise is a judgement that must be made on a case-by-case basis.

### **Ease of Use:**

The chapters should be concise and informative, allowing the user to assimilate and understand as much information as possible in a short time. The format should be identical between chapters, allowing the user to become more efficient with continued use of the system.

### **Efficiency and Cost:**

Being conservative, the flowcharts are likely to direct the user to several potential hazards for any given location. Rather than recommending site investigations for all of these potential hazards, this guide should enable the user to make educated decisions as to the necessity of investigations for each hazard. A list of field indicators of the hazard is included in each chapter; with this knowledge the user can perform site reconnaissance to assess the likelihood of the hazard existing at the site, and possibly eliminate further investigations.

With these considerations in mind, each hazard-specific chapter (Section 3) includes sections for threats posed to engineered works, field indicators, relevant background, site investigation goals and guidelines, possible mitigation options, and references for further reading.

### **Threats Posed to Engineered Works:**

A concise list of impacts that the hazard may have on planned works or land use.

#### Field Indicators:

A concise list of features to identify during initial site reconnaissance to help indicate whether a potential hazard is an actual hazard.

#### Relevant Background:

These sections may include information on some or all of the following: hazard mechanisms, occurrence, engineering characteristics, and associated processes and features. This information is included to aid the user in better assessing the likelihood, severity, and extent of each hazard at the site, and understand the reasoning behind the various techniques of investigation, characterization and mitigation.

#### Site Investigation Goals:

A bulleted list summarizing the site investigation goals, in order to clarify and solidify the investigation guidelines that are listed below.

#### Site Investigation Actions:

Concise guidelines, organized under discreet headings for each action, and ordered to reflect the site investigation goals detailed above. These guidelines include surface and subsurface investigations, field testing, sampling, laboratory testing and the interpretation of field or laboratory test results, where applicable. If standards exist for the characterization of the hazard these are also described.

#### Possible Mitigation Options:

A list of commonly-used techniques for the mitigation of the hazard. Mitigation design and criteria for choosing among mitigation options is outside the scope of this manual, so the mitigation section is typically brief. No detailed explanations of mitigation techniques, relative costs, or criteria for choosing between them, are given. For some hazards, the references provided at the end of the hazard chapters include design criteria or methods. However, in most cases, experienced professionals should be consulted to perform engineering design and economic analysis of mitigation options.

#### References:

A list of useful references, including both the items cited in each chapter, as well as items for further reading on the relevant hazard, including textbooks, government manuals, and scientific publications.

## 1.4 OUTCOMES

The majority of required information is directly available from the internet, and relevant web-addresses have been provided to expedite the research process. Information that is not directly available online can usually be sourced from a government agency. It may be necessary to purchase certain forms of information, such as technical papers. It may be necessary or desirable to perform site reconnaissance to validate or supplement existing information, prior to implementing the flowcharts.

The conservative approach to hazard identification has created simple flowcharts with multiple outcomes. While this is likely to produce extraneous outcomes, it makes it more likely that potential hazards will be identified. It should be remembered that this is a tool to be used in the preliminary stages of site evaluation; the list of potential geologic hazards indicated by the flowcharts can usually be reduced following preliminary site reconnaissance, with the remaining hazards then being evaluated and characterized by specific investigation actions.

The outcomes of the five flowcharts (the hazards that each is able to identify) are displayed in Table 1-1. Each flowchart is capable of identifying between six (topography) and eleven (bedrock) geologic hazards. Between all five flowcharts, every hazard listed in this guide is identifiable. No flowchart is redundant; each flowchart has at least one ‘unique’ hazard, which only that flowchart can identify.

The five flowcharts function independently from one another. Should some of the required information be unavailable, the system still retains a level of functionality. However, if any of the flowcharts are not fully implemented there is a possibility that some potential or actual hazards will not be identified. The conservative principle requires that, should any flowchart be unusable for any reason, the unique outcomes of that flowchart must be considered to be potential hazards at the location. Similarly, if more than one flowchart is unusable, the outcomes table (Table 1-1) should be checked to identify any hazards that are common to the unusable flowcharts, but excluded from the remaining flowcharts. These hazards should be considered to be potential hazards.

The ordered foundation for the identification system allows for the inclusion of ‘new’ hazards should such a situation arise. Once the important causative and associative factors of a geologic hazard are established, the hazard can be incorporated into the relevant flowchart(s) without disrupting the existing system.

The site investigation chapters dovetail with the flowcharts to form a complete system. The inclusion of ‘field indicators’ at the start of each chapter aids the transition from the knowledge of ‘potential hazards’ indicated by the flowcharts to ‘actual hazards’ that are to be characterized through site investigation. It is also likely that the list of potential hazards can be reduced following site reconnaissance, minimizing the amount of hazard-specific site investigations to be carried out. The general format of the site investigation guidelines is repeated throughout the chapters, making them quick and easy to read and understand, especially once the reader becomes familiar with the format.

**Table 1-1** Summary table of flowchart outcomes. No single flowchart is capable of identifying all the potential hazards at a location, and no flowchart is redundant. In order to be confident that all potential hazards at a location have been identified, it is necessary to implement all five flowcharts. Each flowchart has at least one ‘unique’ outcome (denoted by ‘U’). Should a flowchart be unusable for any reason, its unique outcomes must be considered to potentially exist at the location. Similarly, if more than one flowchart is unusable, any hazards that are common to the unusable flowcharts, but excluded from the remaining flowcharts, should be considered to be potential hazards.

Hazards	Flowchart outcomes (potential hazards that a flowchart can identify)				
	Flowchart 1	Flowchart 2	Flowchart 3	Flowchart 4	Flowchart 5
	Bedrock	Surficial Materials	Topography / Geomorphology	Location	Climate
Expansive clay soils	✓	✓			
Expansive clay bedrock	✓ U				
Heaving bedrock	✓ U				
Expansive alkali soils		✓			✓
Frost action					✓ U
Carbonate karst	✓ U				
Evaporite karst	✓ U				
Subsidence due to underground mining				✓ U	
Subsidence due to fluid withdrawal				✓ U	
Collapsible soils			✓		✓
Organic soils and peat		✓			✓
Sensitive clays		✓ U			
Permafrost				✓	✓
Saline soils	✓	✓		✓	✓
Gypsiferous soils	✓	✓			✓
Sulfate soils	✓	✓			✓
Acid sulfate soils	✓	✓		✓	
Sulfide rock	✓			✓	
Sulfide mine tailings				✓ U	
Unstable rock slopes			✓ U		
Unstable soil slopes			✓ U		
Unstable slopes in shale, claystone and other degradable rocks			✓ U		
Talus			✓ U		
Seismic hazards				✓ U	
Active volcanic hazards				✓ U	
Volcanic terrain hazards	✓ U				
Surface water hazards			✓ U		
Coastal hazards				✓ U	
Naturally occurring asbestos	✓			✓	
Wildfire Burn Areas				✓ U	

## 1.5 LIMITATIONS

The system presented here for geologic hazard identification and characterization is expected to be modified as experience in its application accumulates. Also, the range of geologic hazards for which this system has been created is limited to those thought to be detrimental to transportation corridors in the United States at the present time. It is possible that the system will need to include new hazards, and the logic of the identification system allows for them to be easily included without disrupting the existing system.

## 1.6 SELECTED WIDELY APPLICABLE REFERENCES

The following selected references are provided here because each contains information useful for evaluating more than one of the hazards listed in this guide. In addition, some of these references provide useful guidance on site investigation that can be useful for evaluating multiple hazards.

Clayton, C.R.I, and Smith, D.M. 2013. *Effective Site Investigation* (2<sup>nd</sup> ed.). London: ICE Publishing.

Coduto, D.P. 1999. *Geotechnical Engineering: Principles and practices*. Upper Saddle River, New Jersey: Prentice-Hall Inc, 759 p.

Burland, J.B. and Chapman, T. 2012. *ICE Manual of Geotechnical Engineering*. London: ICE Publishing.

Burt, R. (ed.) 2004. *Soil Survey Laboratory Methods Manual*. United States Department of Agriculture, Natural Resource Conservation Service, Soil Survey Investigations Report No. 42.

González de Vallejo, L. I., and Ferrer, M. 2011. *Geological Engineering*. New York, New York: CRC Press/Balkema, 678 p.

Goodman, R.E. 1993. *Engineering Geology: Rock in Engineering Construction*. New York, New York: John Wiley & Sons Inc., 412 p.

Hunt, R.E. 2005. *Geotechnical Engineering Investigation Handbook*. 2nd Ed. Boca Raton, Florida: Taylor & Francis Group, 1066 p.

United States Department of Transportation (USDOT). 1991. *Rock and Mineral Identification for Engineers*. U.S. Department of Transportation, Federal Highway Administration, Report No. FHWA-HI-91-025.



## **SECTION 2**

### **IDENTIFICATION OF POTENTIAL GEOLOGIC HAZARDS**

## 2.1 REVIEW OF REQUIRED INFORMATION

The information required to navigate the flowcharts has been subdivided into sections according to the causative or associative factor to which the information pertains. While these information sections have the same headings as the flowcharts, it is incorrect to assume that, for example, the bedrock flowchart requires only bedrock information. Each flowchart requires information pertaining to a number of factors, therefore it is advisable to obtain as much of the required information as possible before proceeding to the flowcharts. The required information is summarized in Table 2-1. More detailed descriptions of the information and its sources follows the table.

The majority of the required information can be obtained directly from the websites of government agencies such as the U.S. Geological Survey or the U.S. Department of Agriculture. Some information may require communication with these organizations or their state equivalents. In a few cases it may be necessary or desirable to deal with private industry to obtain specific information, such as reports or technical publications.

It is possible that some of the required information will be unavailable. In the case of bedrock, surficial materials and topography, information that is unavailable from the recommended sources can be supplemented by performing site reconnaissance. In fact, if the site is easily accessible, it is recommended to perform reconnaissance to validate the information obtained from literature review. In the case of location and climate, information that is unavailable from the recommended sources may be difficult to obtain by other means. If such a situation occurs, certain flowcharts or parts of flowcharts may be unusable, whereupon the unique outcomes indicated in the unusable flowchart sections should be considered to be potential hazards (this reasoning is more fully explained in Section 1.4).

**Table 2-1** Required information and its sources.

	Required Information	Forms of Information	Sources of Information
<b>Bedrock</b>	What is the bedrock type?	Geologic maps	United States Geological Survey (USGS) maps and imagery: <a href="http://www.usgs.gov/pubprod/maps.html">http://www.usgs.gov/pubprod/maps.html</a>
	If the bedrock is sedimentary, what is the angle of dip of the bedding?		State geologic organizations
	Does the bedrock contain pyrite?	Geologic maps	United States Geological Survey (USGS) maps and imagery: <a href="http://www.usgs.gov/pubprod/maps.html">http://www.usgs.gov/pubprod/maps.html</a>
			State geologic organizations
		Engineering geologic maps	State geologic organizations
		Published literature of specific geologic units or rock groups	Internet search
Visual identification and assessment	Site reconnaissance		
<b>Surficial Materials</b>	Do surficial materials at the site contain any of the following? <ul style="list-style-type: none"> <li>• Clay</li> <li>• Gypsum</li> <li>• Soluble salts</li> <li>• Organics</li> <li>• Pyrite</li> <li>• Asbestos</li> </ul>	Visual identification and assessment	Site reconnaissance
		Soil surveys	United States Department of Agriculture (USDA) soil surveys: <a href="https://websoilsurvey.sc.egov.usda.gov/App/HomePage.htm">https://websoilsurvey.sc.egov.usda.gov/App/HomePage.htm</a>
		Engineering geologic maps	State geologic organizations
	Do surficial materials at the site have a sodium adsorption ratio (SAR) $\geq$ 13?	Soil surveys	United States Department of Agriculture (USDA) soil surveys: <a href="https://websoilsurvey.sc.egov.usda.gov/App/HomePage.htm">https://websoilsurvey.sc.egov.usda.gov/App/HomePage.htm</a>

Table 2-1 (continued)

Required information and its sources.

	Required Information	Forms of Information	Sources of Information
Topography / Geomorphology	Does the site contain any of the following? <ul style="list-style-type: none"> <li>• Sloping ground</li> <li>• Valley or canyon floors</li> <li>• Floodplains</li> </ul>	Topographic maps	United States Geological Survey (USGS) topographic maps: <a href="http://nationalmap.gov/ustopo/index.html">http://nationalmap.gov/ustopo/index.html</a>
		Visual identification and assessment	Site reconnaissance
		Digital elevation data: Digital Elevation Models (DEMs) and LiDAR point clouds	Various internet sources: e.g. United States Geological Survey (USGS) Earth Explorer: : <a href="https://earthexplorer.usgs.gov/">https://earthexplorer.usgs.gov/</a> USGS National Map: <a href="https://www.usgs.gov/core-science-systems/national-geospatial-program/national-map">https://www.usgs.gov/core-science-systems/national-geospatial-program/national-map</a>
	Does the site contain any of the following? <ul style="list-style-type: none"> <li>• Alluvial fans</li> <li>• Colluvial deposits</li> <li>• Debris flow deposits</li> <li>• Loess deposits</li> </ul>	Google Earth or other internet or printed aerial photographs	United States Geological Survey (USGS) Earth Explorer: <a href="https://earthexplorer.usgs.gov/">https://earthexplorer.usgs.gov/</a>
			United States Department of Agriculture (USDA): <a href="http://www.fsa.usda.gov/FSA/apfoapp?area=home&amp;subject=prod&amp;topic=landing">http://www.fsa.usda.gov/FSA/apfoapp?area=home&amp;subject=prod&amp;topic=landing</a>
			Private industry (internet search)
		Visual identification and assessment	Site reconnaissance
		Digital elevation data: Digital Elevation Models (DEMs) and LiDAR point clouds	Various internet sources: e.g. United States Geological Survey (USGS) Earth Explorer: : <a href="https://earthexplorer.usgs.gov/">https://earthexplorer.usgs.gov/</a> USGS National Map: <a href="https://www.usgs.gov/core-science-systems/national-geospatial-program/national-map">https://www.usgs.gov/core-science-systems/national-geospatial-program/national-map</a>

Table 2-1 (continued)

Required information and its sources.

	Required Information	Forms of Information	Sources of Information
Location	Is the site in Alaska or mountains in the western U.S.?	General knowledge	
	Is the site in a low-lying coastal region?	Topographic maps	United States Geological Survey (USGS) topographic maps: <a href="http://nationalmap.gov/ustopo/index.html">http://nationalmap.gov/ustopo/index.html</a>
	Is the site in a region that might be affected by seismic activity?	Seismic hazard maps	United States Geological Survey (USGS) Earthquake Hazards Program: <a href="http://earthquake.usgs.gov/hazards/products/conterminous/2008/maps/">http://earthquake.usgs.gov/hazards/products/conterminous/2008/maps/</a>
	Is the site in a region that might be affected by an active volcano?	Maps of active volcanoes	United States Geological Survey (USGS) Volcano Hazards Program: <a href="https://volcanoes.usgs.gov/index.html">https://volcanoes.usgs.gov/index.html</a>
	Is the site in a region of extensive groundwater or hydrocarbon extraction?	Aquifer maps	United States Geological Survey (USGS) Groundwater Information Pages: <a href="http://water.usgs.gov/ogw/basics.html#aquifers">http://water.usgs.gov/ogw/basics.html#aquifers</a>
		Oil and gas reservoir maps	United States Energy Information Administration (EIA): <a href="https://www.eia.gov/maps/">https://www.eia.gov/maps/</a>
	Is the site: • In a region of coal or metal ore mining? • Above an underground mine?	Mine maps and mining records	National Mine Map Repository (NMMR): <a href="https://mmr.osmre.gov/">https://mmr.osmre.gov/</a>
	Is the site close to a known location of asbestos occurrence?	Asbestos-occurrence maps and datasets	United States Geological Survey (USGS) mineral information pages: <a href="http://minerals.usgs.gov/minerals/pubs/commodity/asbestos/">http://minerals.usgs.gov/minerals/pubs/commodity/asbestos/</a>
	Is the site in a region that might be affected by a wildfire or has been affected by a wildfire in the last 3-4 years?	Google Earth or other internet or printed aerial photographs	United States Geological Survey (USGS) Earth Explorer: <a href="https://earthexplorer.usgs.gov/">https://earthexplorer.usgs.gov/</a>  Private Industry (internet search)
		State or National wildfire databases	Internet search
Visual identification and assessment		Site reconnaissance	
Climate	Is the climate of the site classified as one of the following? • Arid • Temperate • Snow • Polar	Koppen-Geiger climate classification maps	Various internet sources: Koppen-Geiger classification map of the world: <a href="http://koeppen-geiger.vu-wien.ac.at/present.htm">http://koeppen-geiger.vu-wien.ac.at/present.htm</a> Koppen-Geiger classification map of North America: <a href="https://editors.eol.org/eoearth/wiki/K%C3%B6ppen_Climate_Classification_System">https://editors.eol.org/eoearth/wiki/K%C3%B6ppen_Climate_Classification_System</a> Koppen-Geiger classification map of the conterminous United States: <a href="https://catalog.data.gov/dataset/koppen-climate-classification-for-the-conterminous-united-states63aa7">https://catalog.data.gov/dataset/koppen-climate-classification-for-the-conterminous-united-states63aa7</a>



## 2.1.1 Bedrock Information

### Required Information

- What is the type (genetic classification) of bedrock beneath the site?
- If the bedrock beneath the site is sedimentary, what is the angle of the dip of the bedding?
- Does the rock contain pyrite?

### Sources of Information

#### *Bedrock Type and the Angle of Dip of Sedimentary Bedding*

Certain rock types are expected to contain mineral components or to have structural or strength properties that are indicative of certain geologic hazards. This has been accounted for in the hazard identification flowcharts and means that, for the most part, entering the flowcharts with knowledge of the bedrock type is sufficient to identify potential hazards.

Geologic maps document the types and distribution of bedrock beneath a given area, and usually detail the general angle of dip of any sedimentary units. Furthermore, geologic maps often contain useful information about rock structure, relative strength, weathering characteristics and composition that may be useful in characterizing bedrock-related hazards.

Geologic maps can be obtained from the United States Geological Survey (USGS) or the relevant state geological organizations. USGS geologic map resources can be accessed through their website<sup>1</sup>. State geological organizations can usually be found through an internet search.

#### *Pyrite Content*

Although uncommon, pyrite in bedrock in significant quantities can cause problems in soils developed over this bedrock. However, since pyrite can occur in such a wide variety of rock-types, the presence of pyrite cannot be reliably inferred from bedrock type. Therefore, the presence of pyrite must be established from rock composition information obtained in geologic maps, engineering geologic maps or published literature, or by conducting site reconnaissance to look for pyritic bedrock.

More detailed geologic maps may mention the occurrence of pyrite in rock groups, if it is significant. Similarly, engineering geologic maps may mention pyrite occurrence if it is significant enough to impact engineering works. Geologic maps can be obtained from the United States Geological Survey (USGS) or the relevant state geological organizations, as described above. Engineering geologic maps, where available, can be obtained from relevant state geological organizations.

More detailed information about rock composition can usually be found in published literature. A web-search of the rock-group in question (such as “Pierre Shale”, or “Fox Hills Sandstone”) is likely to return published material containing detailed geologic and engineering information. It

---

<sup>1</sup> <http://www.usgs.gov/pubprod/maps.html>

is important to note that rock composition may vary; a study of the Pierre Shale at location A may not reflect the Pierre Shale at location B, but such research is useful in recognizing potentially pyritic rocks.

The most definitive means of assessing pyrite content in bedrock is by conducting site reconnaissance. Pyrite occurs most often as small, disseminated grains that have a cubic shape, a pale brassy-yellow color (tarnishing to grey) and a metallic luster. Weathering of pyrite produces iron staining on rock faces. Procedures for the identification of pyrite in the field are detailed in Rock and Mineral Identification for Engineers<sup>2</sup>.

### **2.1.2 Surficial Materials Information**

#### **Required Information**

- Do surficial materials at the site contain any of the following?
  - Clay
  - Gypsum
  - Soluble salts
  - Organics
  - Pyrite
  - Asbestos
- Do surficial materials at the site have a sodium adsorption ratio (SAR) of 13 or greater?

#### **Sources of Information**

United States Department of Agriculture (USDA) soil surveys are compiled by the Natural Resource Conservation Service (NRCS) and are available online via an interactive mapping tool<sup>3</sup>. They provide information of the top eighty inches (2 meters) of surficial cover, including:

- Clay percent by weight
- Gypsum percent by weight
- Electrical conductivity (an indicator of the concentration of water-soluble salts)
- Organic percent by weight
- pH (if soils are acidic it may be as a result of pyrite oxidation)
- Sodium adsorption ratio (SAR)

USDA soil surveys also contain information on soil physical properties, erosion factors, permeability, frost susceptibility and groundwater levels, as well as guidelines on the suitability and limitations for construction and land use.

---

<sup>2</sup> United States Department of Transportation (USDOT). 1991. Rock and Mineral Identification for Engineers. U.S. Department of Transportation, Federal Highway Administration, Report No. FHWA-HI-91-025.

<sup>3</sup> <https://websoilsurvey.sc.egov.usda.gov/App/HomePage.htm>

The most definitive means of assessing pyrite content in surficial materials is by conducting site reconnaissance. Field indicators of acid sulfate soils (indicative of pyrite in soils) are detailed in Section 3.16. Procedures for the identification of pyrite in the field are detailed in Rock and Mineral Identification for Engineers<sup>4</sup>.

Engineering geologic maps will provide useful information of surficial materials, probably with more emphasis on characteristics that may affect engineering works. Engineering geologic maps, where available, can be obtained from relevant state geological organizations. State geological organizations can usually be found through an internet search.

### **2.1.3 Topography and Geomorphology Information**

#### **Required Information**

Does the site contain any of the following?

- Sloping ground
- Valley or canyon floors
- Flood plains
- Alluvial fans
- Colluvial deposits
- Debris flow deposits
- Loess deposits

#### **Sources of Information**

Topographic maps clearly define sloping ground, valleys and canyons. Most topographic maps also display rivers and streams, and can be used to identify flood plains. Topographic maps can be obtained from the United States Geological Survey (USGS)<sup>5</sup>.

Alluvial fans, colluvial, debris flow and loess deposits are more accurately identified by Google Earth or other internet or printed aerial photographs. Stereographic viewing of aerial photograph pairs can further assist in identifying these features. Aerial photographs can be obtained from the United States Geological Survey (USGS), the United States Department of Agriculture (USDA), or through private industry. USGS aerial photo resources can be accessed through their website<sup>6</sup>. USDA aerial photo resources can be accessed through the Aerial Photography Field Office (APFO) of the Farm Service Agency (FSA)<sup>7</sup>. Private industry providers of aerial photographs can usually be found through an internet search.

---

<sup>4</sup> United States Department of Transportation (USDOT). 1991. Rock and Mineral Identification for Engineers. U.S. Department of Transportation, Federal Highway Administration, Report No. FHWA-HI-91-025

<sup>5</sup> <http://nationalmap.gov/ustopo/index.html>

<sup>6</sup> <https://earthexplorer.usgs.gov/>

<sup>7</sup> <http://www.fsa.usda.gov/FSA/apfoapp?area=home&subject=prod&topic=landing>

Digital elevation models (DEMs) and Light Detection and Ranging (LiDAR) point cloud data are also useful for describing topography, sometimes with great detail (~1m resolution or greater). DEMs are available as raster spatial datasets from USGS Earth Explorer<sup>2</sup> with resolutions up to 10m per pixel. Higher resolution DEMs and LiDAR point clouds are also available from the USGS National Map<sup>8</sup>.

It should be recognized that, while distinctive topographic or geomorphic features may have been modified by development, their associated geologic hazards may remain. This problem applies mainly to the bases of slopes (alluvial fans, colluvial deposits and debris flow deposits). In this case, aerial stereo-photographs taken prior to development may be of use.

#### **2.1.4 Location Information**

##### **Required Information**

Is the site:

- In Alaska or high mountains in the western U.S.?
- In a low-lying coastal region?
- In a region that might be affected by seismic activity?
- In a region that might be affected by an active volcano?
- In a region of extensive groundwater or hydrocarbon extraction?
- In a region of coal or metal ore mining?
- Above an underground mine?
- Close to a known location of asbestos occurrence?
- In a region that might be affected by a wildfire, or was affected by a recent wildfire?

##### **Sources of Information**

###### ***Low-Lying Coastal Regions***

Sites that are in low lying coastal regions can be easily recognized on topographic maps that can be obtained from the United States Geological Survey (USGS)<sup>9</sup>. In the context of recognizing the potential for acid sulfate soils; low-lying coastal regions have elevation less than ten meters above sea level, and laterally extend to include all areas that are affected by salt water, such as estuaries, tidal flats and coastal wetlands.

###### ***Regions Affected By Seismic Activity***

When identifying regions that are affected by seismic activity, it is first necessary to define the seismic event for which the proposed works are to be designed. This is usually expressed as an event with a certain probability of occurrence in a given time period. For example; the AASHTO seismic design criterion specifies a seismic event with a 7% probability of occurrence

---

<sup>8</sup> <https://www.usgs.gov/core-science-systems/national-geospatial-program/national-map>

<sup>9</sup> <http://nationalmap.gov/ustopo/index.html>

in 75 years. The United States Geological Survey (USGS) National Seismic Hazard Mapping Project has produced hazard mapping images and data for the entire US, showing areas that would experience seismic motion, and the probable ground acceleration, during seismic events of various probabilities and return periods. The USGS seismic hazard maps are accessible online<sup>10</sup>.

### ***Regions Affected By Active Volcanoes***

The United States Geological Survey (USGS) Volcano Hazards Program has mapped active volcanoes in the U.S., and maintains current data of volcanic activity and alert levels for individual volcanoes. The USGS has recognized regions of the U.S. affected by active volcanoes:

- Alaska
- Cascades (CA, OR, WA)
- Hawaiian Islands
- Long Valley Volcanic Centre (CA)
- Marianas Islands
- Yellowstone (WY)

The USGS map of active volcanoes in the U.S. can be found online<sup>11</sup>, as can more detailed information of volcanoes in specific regions<sup>12</sup>.

### ***Regions of Extensive Groundwater or Hydrocarbon Extraction***

The US Geological Survey has detailed maps of aquifers in the U.S. that are accessible online<sup>13</sup>. The U.S. Energy Information Administration has detailed maps of oil and gas reservoirs in the U.S. that are also available online<sup>14</sup>.

### ***Coal or Metal Ore Mining, and Underground Mines***

Mining activities in the U.S. are well documented and records have been compiled by the National Mine Map Repository (NMMR), part of the U.S. Department of the Interior's Office of Surface Mining. NMMR resources are accessible online<sup>15</sup>. Available information is extensive and includes type of mine and mapped locations. A list of additional state mining information repositories is also available from NMMR<sup>16</sup>.

---

<sup>10</sup> <http://earthquake.usgs.gov/hazards/products/conterminous/2008/maps/>

<sup>11</sup> <http://volcanoes.usgs.gov/>

<sup>12</sup> <https://volcanoes.usgs.gov/index.html>

<sup>13</sup> <http://water.usgs.gov/ogw/basics.html#aquifers>

<sup>14</sup> <https://www.eia.gov/maps/>

<sup>15</sup> <https://mmr.osmre.gov/>

<sup>16</sup> [https://mmr.osmre.gov/MMR\\_Links.aspx](https://mmr.osmre.gov/MMR_Links.aspx)

## *Asbestos Occurrence*

The occurrence of asbestos in the United States has been well documented by the USGS as part of their Mineral Information pages. Special publications of asbestos statistics and information have been compiled for the following regions:

- California
- Eastern United States
- Central United States
- Rocky Mountain States of the United States (CO, ID, MT, NM, WY)
- Southwestern United States (AZ, NV, UT)
- Oregon and Washington

These special publications are available online<sup>17</sup> and include maps of natural asbestos occurrence, and datasets including exact locations, host rocks and useful references.

### **2.1.5 Climate Information**

#### **Required Information**

Is the climate of the site classified as one of the following?

- Arid
- Temperate
- Snow
- Polar

#### **Sources of Information**

The climate types listed above are taken from the widely used and accepted Koppen-Geiger climate classification scheme (Kottek et al., 2006). The scheme uses vegetation, precipitation and temperature to classify climate types for the entire globe.

Due to its widespread use, a wealth of Koppen-Geiger information and imagery can be found online, including:

- A short description of the Koppen-Geiger classification scheme<sup>18</sup>.
- The Koppen-Geiger classification map of the world<sup>19</sup>.
- The Koppen-Geiger classification map of North America<sup>20</sup>.
- The Koppen-Geiger classification map of the conterminous United States<sup>21</sup>.

---

<sup>17</sup> <http://minerals.usgs.gov/minerals/pubs/commodity/asbestos/>

<sup>18</sup> [http://koeppen-geiger.vu-wien.ac.at/pdf/Paper\\_2006.pdf](http://koeppen-geiger.vu-wien.ac.at/pdf/Paper_2006.pdf)

<sup>19</sup> <http://koeppen-geiger.vu-wien.ac.at/present.htm>

<sup>20</sup> [https://editors.eol.org/eoearth/wiki/K%C3%B6ppen\\_Climate\\_Classification\\_System](https://editors.eol.org/eoearth/wiki/K%C3%B6ppen_Climate_Classification_System)

<sup>21</sup> <https://catalog.data.gov/dataset/koppen-climate-classification-for-the-conterminous-united-states63aa7>

## **2.2 FLOWCHARTS TO IDENTIFY POTENTIAL GEOLOGIC HAZARDS**

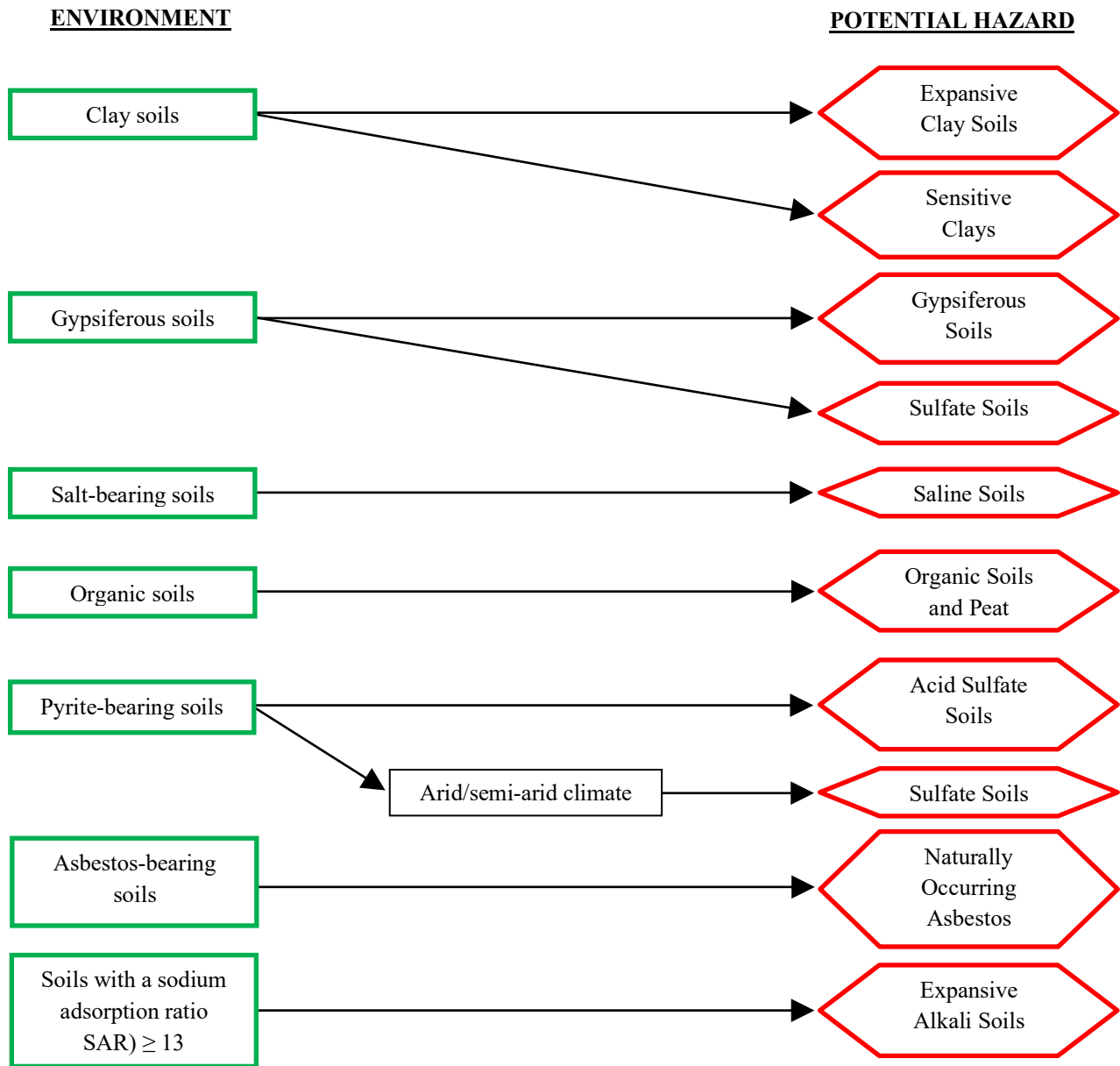
The five flowcharts function independently to identify potential hazards at the location of interest. Each flowchart begins with information from a different causative or associative factor. The navigation of each flowchart also requires some information of other factors. It is recommended that the information review (Section 2.1) be completed before the flowcharts are utilized.

Should some of the required information be unavailable, all or part of a flowchart may become unusable. Therefore, a geologic hazard could exist at the site that is not identified. The conservative principle requires that should any part of a flowchart be unusable for any reason, the unique outcomes of that flowchart must be considered to be potential hazards at the location. Similarly, if more than one flowchart is unusable, the outcomes table (Table 1-1) should be checked to identify any hazards that are common to the unusable flowcharts, but excluded from the remaining flowcharts. These hazards should also be considered to be potential hazards. This concept is described more fully in Section 1.4.

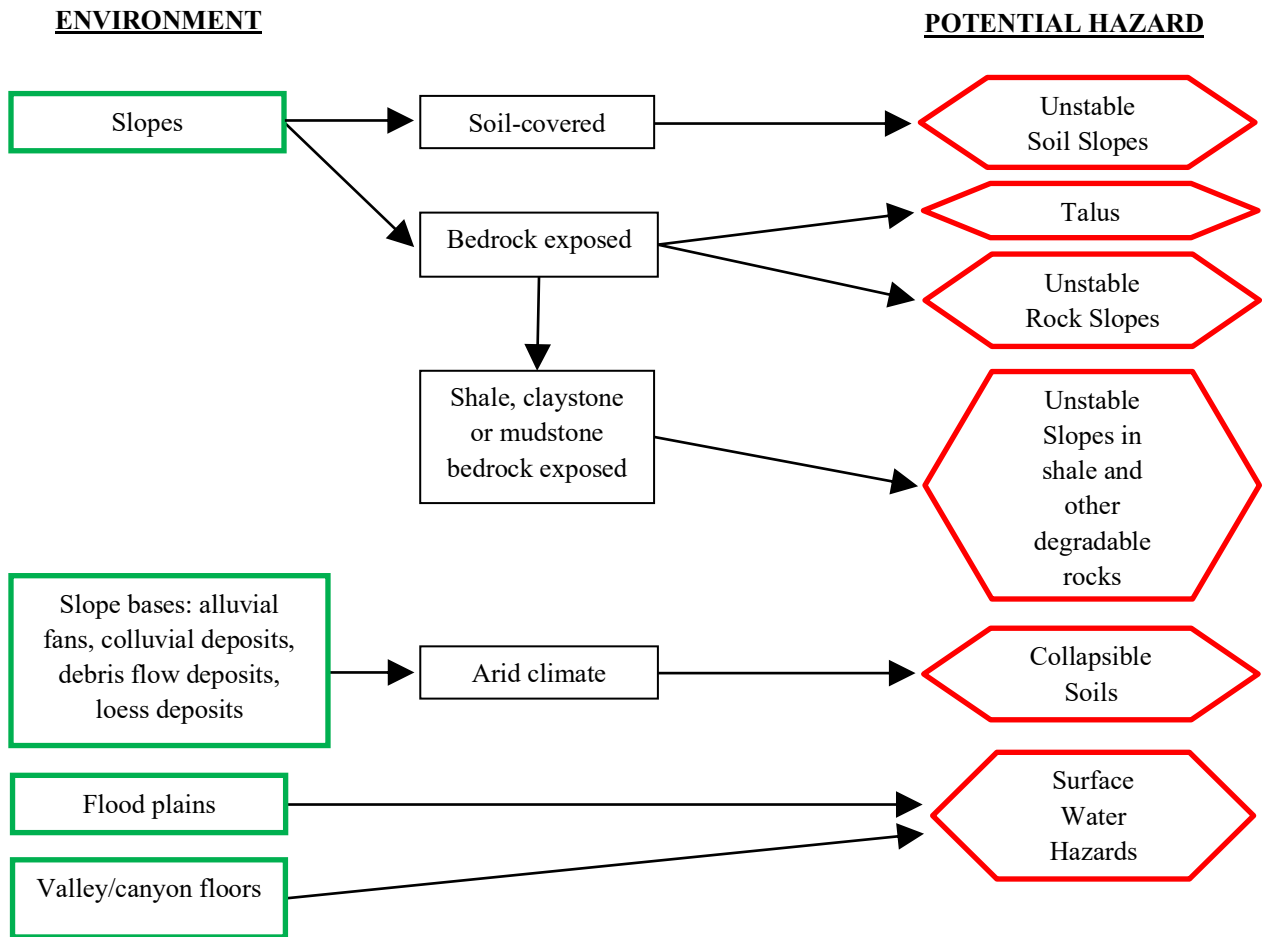




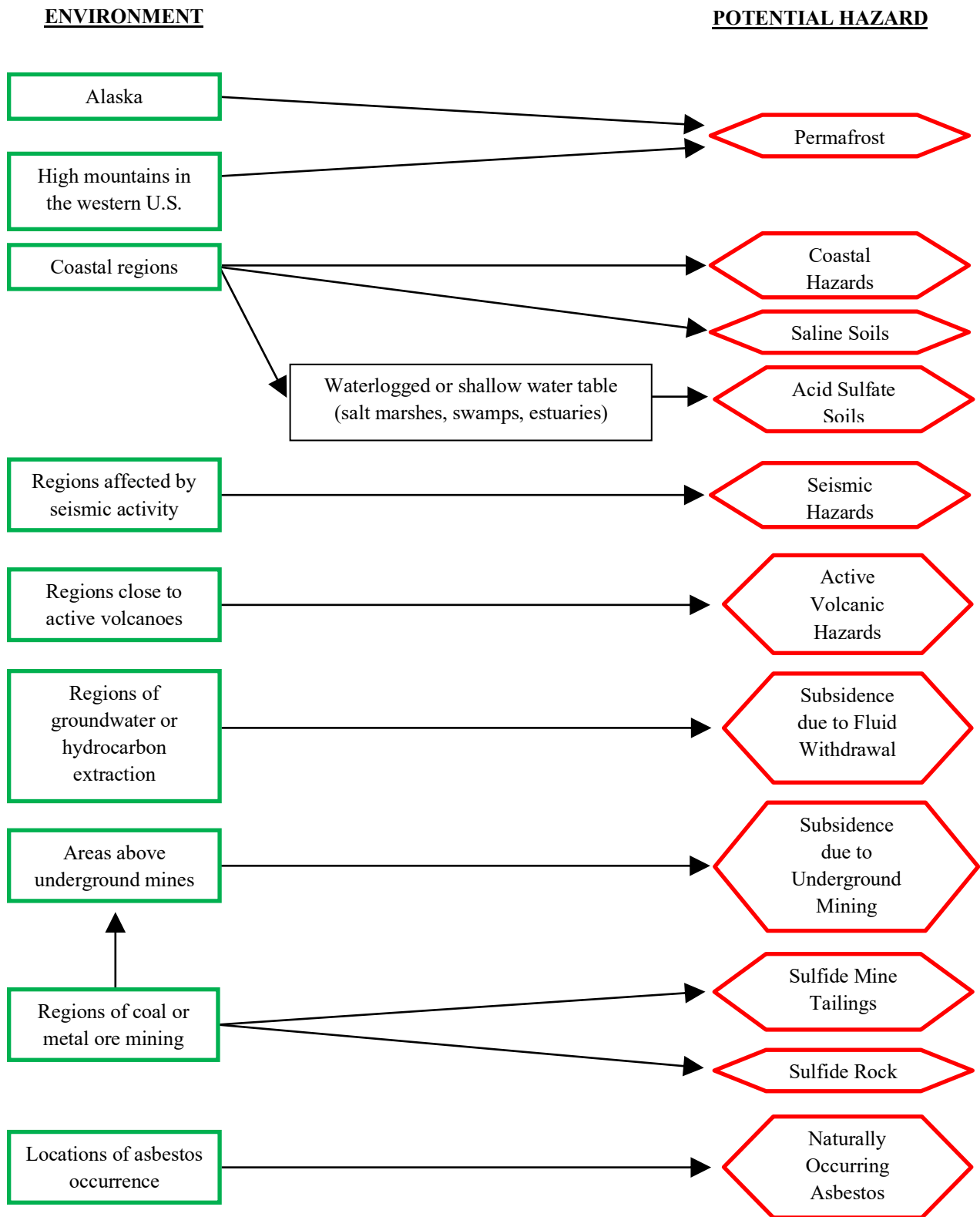
## 2.2.2 Surficial Materials Flowchart



### 2.2.3 Topography and Geomorphology Flowchart



## 2.2.4 Location Flowchart





**SECTION 3**

**GUIDELINES FOR GEOLOGIC HAZARD INVESTIGATION  
AND CHARACTERIZATION**

### **3.1 EXPANSIVE CLAY SOILS AND BEDROCK**

#### **THREATS POSED TO ENGINEERED WORKS**

- Swelling (upon wetting) can produce high expansion pressures, heaving lightly loaded foundations
- Shrinking (upon drying) can cause significant differential settlement

#### **FIELD INDICATORS OF EXPANSIVE CLAY SOILS**

##### **Dry Conditions**

- Desiccation cracks in soil surface
- Popcorn-like soil texture at surface
- High dry-strength of soil clods and surface irregularities
- Glazed surfaces where soil has been cut or graded

##### **Wet Conditions**

- Soil is sticky and clingy
- Heavy equipment develops a coating of soil on wheels, tracks or rollers
- Smooth and shiny surfaces where soil has been cut or graded
- Soil can be easily molded by hand

#### **FIELD INDICATORS OF EXPANSIVE CLAY BEDROCK**

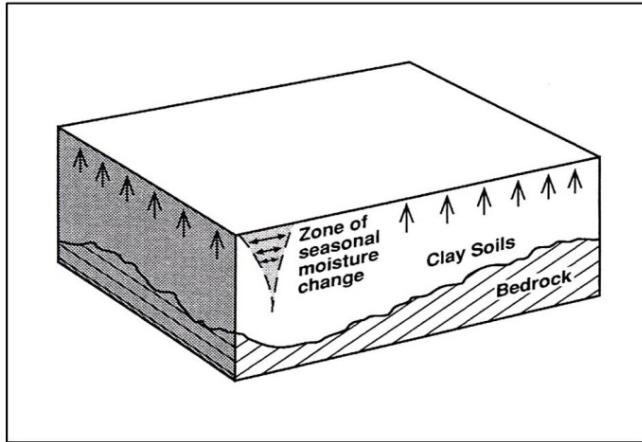
- Expansive clay rocks are typically claystones, clay shales, marine shales and mudstones
- Exposed rock is usually disintegrating, being highly broken and micro-fissured
- Rock in the weathered zone commonly exists as hard fragments in a soil matrix
- Transition between bedrock and residual soil is usually gradual
- Residual soils are highly expansive clays (see field indicators of expansive clay soils, above)

#### **MECHANISMS OF CLAY EXPANSION AND SHRINKAGE**

The absorption of water by clays causes swelling of soils, while their drying causes shrinking. Swelling produces both vertical and lateral pressures; volume increase is usually vertical as this is most often the direction of least confining pressure.

Highly plastic clays, such as smectite, have the ability to absorb large quantities of water and impart accordingly high swell potentials to a soil. An expansive clay material can be characterized by its 'swell potential' and/or its 'swell capacity'. Swell potential is an empirical expression of a soil's potential for volume change, calculated with information of the soil's index properties and fines component. Swell capacity is an empirical expression of a soil's potential for volume change or swelling pressure, derived directly from laboratory or field tests.

Shrink-swell behavior is most common in the upper few meters of clay-rich soil that is affected by seasonal moisture change, as shown in Figure 3-1. The zone over which shrink-swell occurs is called the active zone; the base of the active zone is the depth below which moisture content remains nearly constant.



**Figure 3-1** Block diagram of swelling clay soils. Shrink-swell behavior and vertical heaving occurs within the zone of seasonal moisture change. From Noe and Dodson (1999).

In wet regions, drainage of the subsurface or unusually dry weather may cause shrinkage of clay-rich materials and associated settlement. In dry regions, wetting of the subsurface or unusually wet weather may cause swelling of clay-rich materials and associated heave. Structures covering the soil may retard evaporation and concentrate infiltration at their margins, leading to a general wetting of soils.

## **SITE INVESTIGATION GOALS**

- a) Determine the types and depths of subsurface materials (through trenching or boring).
- b) Determine the depth of the active zone (through sampling and laboratory testing).
- c) Assess the swell potential and swell capacity of subsurface materials (through sampling and laboratory testing).

## **SITE INVESTIGATION ACTIONS**

### **Trenching**

Trenching allows for study of the soil profile, identification of clay layers and the recovery of samples for laboratory analysis. Soil units can initially be characterized by visual inspection, and revised after laboratory testing. Trenches provide more detail of subsurface conditions than do borings, but are limited in terms of depth.

### **Borings**

Borings are used to study the soil profile, identify clay layers and the base of the active zone, and to recover samples for laboratory analysis. Detailed boring logs should be created. Soil units can initially be characterized by visual inspection, and revised after laboratory testing. Boring depths and spacing depend upon the nature of the planned works.

## Sampling

Representative samples are required to assess the swell potential and swell capacity of soils, and to determine the depth of the active zone. Samples should be taken of all soil and rock units that may be expansive, and at regular intervals within apparently homogeneous materials. For assessment of swell potential and moisture content, disturbed samples are sufficient. For assessment of swell capacity, undisturbed samples are necessary.

## Laboratory Testing

Assessment of swell potential:

- Liquid and plastic limits, plasticity index (AASHTO T 90; ASTM D4318)
- Hydrometer analysis (AASHTO T 88; ASTM D422)

Assessment of swell capacity:

- One-dimensional swell test (ASTM D4546)

Finding the base of the active zone:

- Moisture content of soil and rock (AASHTO T 265; ASTM D2216)

## Interpretation of Laboratory Results

Seed's Swell Potential is perhaps the most widely used method for determination and classification of swell potential (Seed et al. 1962):

$$\text{Seed's Swell Potential (\%)} = 3.6 \times 10^5 (A^{2.44})(C^{3.44})$$

Where:  $A$  = Activity of clay (Plasticity Index / Clay weight fraction from hydrometer analysis)  
 $C$  = Percentage of clay sizes from hydrometer analysis

<b>Seed's Swell Potential (%)</b>	> 25 %	5 – 25%	1.5 – 5%	0 – 1.5%
<b>Seed's Swell Potential Rating</b>	Very High	High	Moderate	Low

The one-dimensional swell test indicates the swelling pressure (at constant volume) or volume change (under a constant confining pressure) produced by uptake of water. These findings should be related to the planned structural load to be applied to the soil and the thickness of swelling units. Caution should be taken when applying swell test results to the field; the tests are performed on small samples of soil and do not account for macro-structures in the subsurface, or environmental conditions.



## POSSIBLE MITIGATION OPTIONS

- Avoidance
- Maintaining the subsurface moisture content at a constant level
- Excavation of expansive materials
- Application of surcharge pressure
- Incorporating swell potential into foundation design
- Anchoring foundations below the active zone
- Mixing swelling soils with a chemical binder, such as fly ash or cement, or with a physical binder, such as natural or artificial fibers

## RECOMMENDED AND CITED REFERENCES

Ikeagwuani, Chijioke Christopher, and Nwonu, Donald Chimobi. 2019. Emerging trends in expansive soil stabilisation: A review. *Journal of Rock Mechanics and Geotechnical Engineering*, Vol 11, Iss. 2, pp. 234-440.

Jones, Lee D., and Jefferson, I. 2012. "Chapter 33: Expansive Soils." In *ICE Manual of Geotechnical Engineering, Volume 1 - Geotechnical Engineering Principles, Problematic Soils and Site Investigation*, John Burland, Tim Chapman, Hilary Skinner, and Michael Brown eds. London: ICE Publishing.

Nelson, John D., Kuo Chieh Chao, Daniel D. Overton, and Erik J. Nelson. *Foundation Engineering for Expansive Soils*, Hoboken, New Jersey: John Wiley & Sons, 2015.

Nicholson, Peter G. 2015. *Soil Improvement and Ground Modification Methods*. Kidlington, Oxford, UK : Butterworth-Heinemann, 445p.

Noe, D.C., and Dodson, M.D. 1999. *Heaving Bedrock Hazards Associated with Expansive, Steeply Dipping Bedrock in Douglas County, Colorado*. Colorado Geological Survey, Special Publication 42.

Sabatini, P.J., Bachus, R.C., Mayne, P.W., Schneider, J.A., and Zettler, T.E. 2002. *Expansive Soils*. In *Geotechnical Engineering Circular No. 5: Evaluation of Soil and Rock Properties (Section 7.3)*. US Department of Transportation, Report No. FHWA-IF-02-034.

Samtani, N.C., Nowatzki, E.A. 2006. *Evaluation of Swell Potential*. In *Soils and Foundations Reference Manual (Section 5.7.1.1)*. U.S. Department of Transportation, Report No. FHWA-NHI-06-088.

Seed, H.B., Woodward, J.R. and Lundgren, R. 1962. Prediction of Swelling Potential for Compacted Clays. *Journal of the Soil Mechanics and Foundations Division*, 1962, Vol. 88, Issue 3, Pg. 53-87.

Snethen, D.R., and Townsend, F.C. 1975. A Review of Engineering Experiences with Expansive Soils in Highway Subgrades. U.S. Department of Transportation, Report No. FHWA-RD-75-48.

Snethen, D.R. 1980. Technical Guidelines for Expansive Soils in Highway Subgrades. U.S. Department of Transportation, Report No. FHWA-RD-79-51.

Snethen, D.R. 1980. Expansive Soil in Highway Subgrades: Summary. U.S. Department of Transportation, Report No. FHWA-TS-80-236.

## 3.2 HEAVING BEDROCK

### THREATS POSED TO ENGINEERED WORKS

- Differential expansion pressures and associated heave across steeply dipping bedrock strata (following wetting and expansion)
- Differential settlement across bedrock strata (following drying and shrinkage)

### FIELD INDICATORS OF HEAVING BEDROCK

- Shales, claystones, or mudstones with a bedding dip angle greater than 30 degrees, and at a depth of 10 feet or less below the base of planned works
- Longitudinal heave features at the ground surface
- The presence of expansive clay soils (Section 3.1), combined with the presence of bedrock as described above
- The presence of gypsum or calcite in bedrock fractures, as alteration products of bentonite clays

### MECHANISMS OF DIFFERENTIAL HEAVING OF BEDROCK

The absorption of water by clays in weathered, clay-rich bedrock causes swelling, while their drying causes shrinking. Swelling produces both vertical and lateral pressures; volume increase is usually vertical as this is most often the direction of least confining pressure.

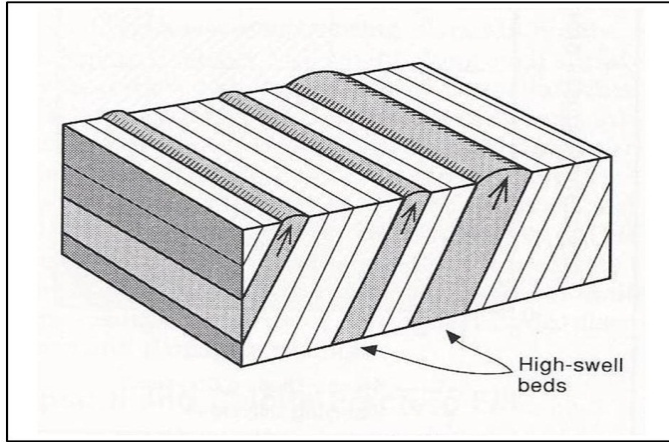
A rock's swell potential reflects the potential magnitude of volume change, as a percentage, and is controlled by the types and abundance of clays within it. Highly plastic clays, such as smectite, have the ability to absorb large quantities of water and impart accordingly high swell potentials to bedrock.

Heaving Bedrock describes the situation that arises when beds of varying swell potential meet the surface at an appreciable angle from the horizontal, resulting in heave features that are continuous with the strike of the strata but variable perpendicular to the strike, as shown in Figure 3-2. Asymmetrical heave features may form when shear-slip movement occurs along bedding planes or fracture surfaces, as shown in Figure 3-3. Heaving bedrock occurs almost exclusively in interbedded sedimentary successions containing shales, mudstones and claystones.

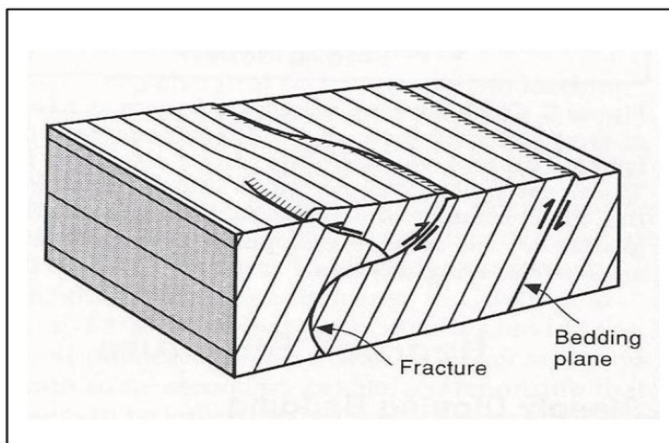
The depth to which shrink-swell behavior occurs in heaving bedrock is highly variable, and can potentially be quite significant, depending on the depth of moisture penetration in the various beds.

### SITE INVESTIGATION GOALS

- a) Determine the subsurface structure, materials and bedding attitude (through trenching and boring).
- b) Identify the swell potentials of subsurface materials (through sampling and laboratory testing).



**Figure 3-2** Block diagram of heaving bedrock. The vertical heave of individual beds varies with swell potential. Heave features are aligned with the strike of the strata; heave is variable across the strata. From Noe and Dodson (1999).



**Figure 3-3** Block diagram of heaving bedrock in which asymmetrical heave features have formed due to shear-slip movement along fractures and bedding planes. From Noe and Dodson (1999).

## SITE INVESTIGATION ACTIONS

### Trenching

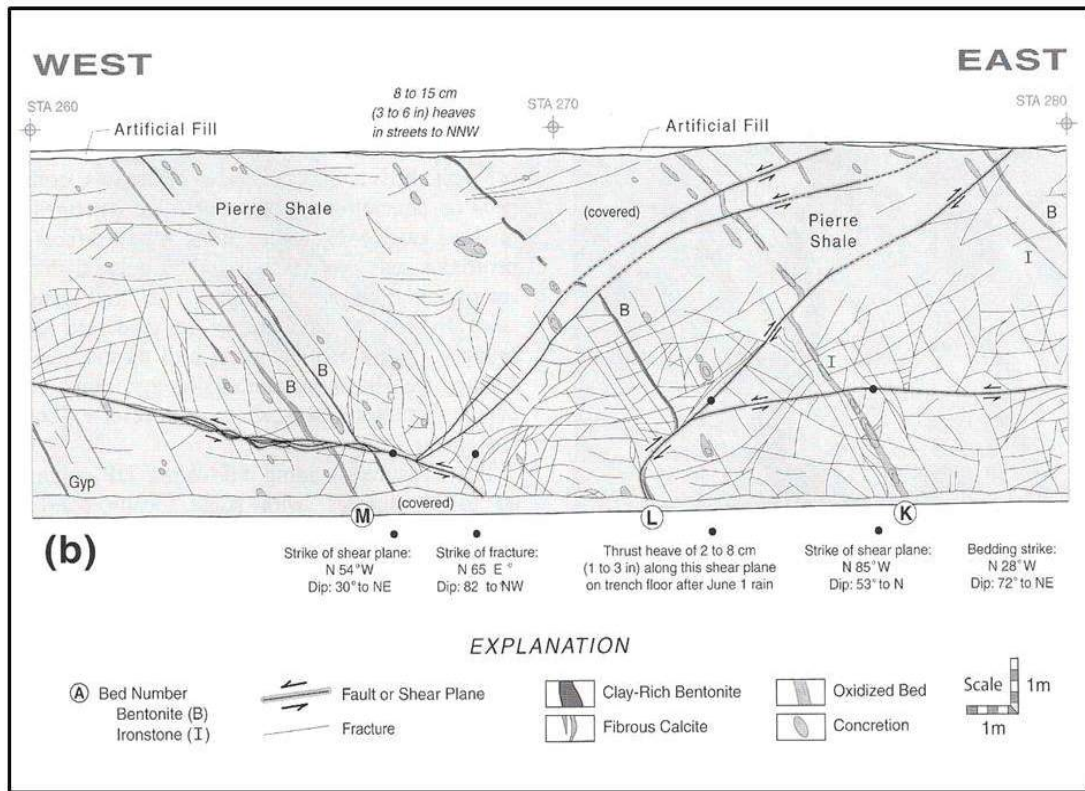
Trenching in heaving bedrock allows identification and documentation of bedding structure, geometry and lithologies, and the recovery of samples for laboratory analysis. Trenches provide more detail of subsurface conditions than do borings, but are limited in terms of depth.

For heaving bedrock investigation trenches should be aligned perpendicularly to the strike of the strata, their depth and length depending largely upon the nature of the planned works. Parallel trenches should be dug some distance apart in order to assess the continuity of the strata. Detailed trench logs should be created, an example is shown in Figure 3-4.

### Borings

Borings in heaving bedrock allows identification and documentation of bedding structure, geometry and lithologies, and the recovery of samples for laboratory analysis; all from depths greater than can be reached by trenching. Boring depths and spacing depend upon the nature of the planned works. The drilling method depends largely upon the nature of the subsurface material but it is important that each boring is continuously logged. Detailed cross sections

should be created from the boring logs. Subsurface conditions in steeply dipping bedded strata can be highly variable over even short distances; extrapolation should not be relied upon.



**Figure 3-4** Example trench log from an area prone to heaving bedrock near Denver, CO. Note identical vertical and horizontal scales, and detail of structure and materials. From Noe et al (2007).

### Sampling

Samples should be taken of all materials encountered in trenches and borings, except those that are clearly non-expansive. For the assessment of swell potential disturbed samples are sufficient, for the assessment of swell capacity undisturbed samples are necessary.

### Laboratory Testing

Assessment of swell potential:

- Liquid and plastic limits, plasticity index (AASHTO T 90; ASTM D4318)
- Hydrometer analysis (AASHTO T 88; ASTM D1140)

Assessment of swell capacity:

- One-dimensional swell test (ASTM D4546)

## Interpretation of Laboratory Results

Seed's Swell Potential is perhaps the most widely used method for determination and classification of swell potential (Seed et al. 1962):

$$\text{Seed's Swell Potential (\%)} = 3.6 \times 10^5 (A^{2.44})(C^{3.44})$$

Where:  $A$  = Activity of clay (Plasticity Index / Clay weight fraction from hydrometer analysis)  
 $C$  = Percentage of clay sizes from hydrometer analysis

<b>Seed's Swell Potential (%)</b>	> 25 %	5 – 25%	1.5 – 5%	0 – 1.5%
<b>Seed's Swell Potential Rating</b>	Very High	High	Moderate	Low

The one-dimensional swell test indicates the swelling pressure (at constant volume) or volume change (under a constant confining pressure) produced by uptake of water. These findings should be related to the planned structural load to be applied to the soil and the thickness of swelling units. Caution should be taken when applying swell test results to the field; the tests are performed on small samples of soil and do not account for macro-structures in the subsurface, or environmental conditions.

The most damaging feature of heaving bedrock is the *variability* of swelling pressure and heave beneath a site or foundation; laboratory results should be assessed with this in mind.

## POSSIBLE MITIGATION OPTIONS

- Avoidance
- Maintaining the soil moisture content at a constant level
- Excavating and backfilling sufficient depth of non-expansive fill between foundations and heaving bedrock
- Incorporating swell potential into foundation design

## RECOMMENDED AND CITED REFERENCES

Lamb, D.R., and Hannah, S.J. 1973. Proceedings of Workshop on Expansive Clays and Shales in Highway Design and Construction. U.S. Department of Transportation, Report No. FHWA-RD-73-72.

Nelson, John D., Kuo Chieh Chao, Daniel D. Overton, and Erik J. Nelson. Foundation Engineering for Expansive Soils Hoboken, New Jersey: John Wiley & Sons, 2015.

Noe, D.C., Higgins, J.D., and Olsen, H.W. 2007. Steeply Dipping Heaving Bedrock, Colorado: Part 1 – Heave features and Physical Geological Framework. *Environmental and Engineering Geoscience*, Vol. XIII, No. 4, November 2007, pp.289-308.

Noe, D.C., and Dodson, M.D. 1999. Heaving Bedrock Hazards Associated with Expansive, Steeply Dipping Bedrock in Douglas County, Colorado. Colorado Geological Survey, Special Publication 42.

Seed, H.B., Woodward, J.R. and Lundgren, R. 1962. Prediction of Swelling Potential for Compacted Clays. *Journal of the Soil Mechanics and Foundations Division*, 1962, Vol. 88, Issue 3, Pg. 53-87.

Snethen, D.R., and Townsend, F.C. 1975. A Review of Engineering Experiences with Expansive Soils in Highway Subgrades. U.S. Department of Transportation, Report No. FHWA-RD-75-48.

Snethen, D.R. 1980. Technical Guidelines for Expansive Soils in Highway Subgrades. U.S. Department of Transportation, Report No. FHWA-RD-79-51.

Snethen, D.R. 1980. Expansive Soil in Highway Subgrades: Summary. U.S. Department of Transportation, Report No. FHWA-TS-80-236.

### 3.3 EXPANSIVE ALKALI SOILS

#### THREATS POSED TO ENGINEERED WORKS

This section addresses geohazards resulting from non-saline alkali (sodic) soils. These are soils that have high sodium content in compounds such as  $\text{NaCO}_3$  (i.e. “sodic”) but not high salt contents (see Section 3.13 for saline soil geohazards).

- Expansion of soils and upward heave
- Calcium carbonate crust commonly formed a short distance below the surface
- Low infiltration capacity and associated high rates of surface run-off, due to the loss of soil structure and formation of limestone crust.

•

#### FIELD INDICATORS OF EXPANSIVE ALKALI SOILS

- Upper soil layers powdery and loose when dry (no structure)
- Fibers of wooden posts swelled and disrupted just above ground level
- Spalling or flaking of concrete in contact with the soil
- Narrow white outline around damp areas in the shade
- Limestone crust short distance below surface

#### MECHANISM OF EXPANSION OF ALKALI SOILS

Alkali soils have a high concentration of sodium carbonate ( $\text{NaCO}_3$ ). When they also contain clay the following chemical processes may take place:

- $\text{NaCO}_3$  reacts with water to form sodium hydroxide, causing high alkalinity
- $\text{NaCO}_3$  reacts with calcium of the clay particles to precipitate solid calcium carbonate
- Sodium ions replace the calcium lost from the clays, inducing expansion and a deterioration of the soil structure

#### OCCURRENCE OF SODIUM CARBONATE ( $\text{NaCO}_3$ ) IN SOILS

Sodium carbonate in soils originates from the breakdown of natural minerals, or from the long-term application of irrigation water rich in sodium carbonate or bicarbonate. It is transported in solution in ground or surface water. High concentrations of  $\text{NaCO}_3$  evolve in soils when consistently more  $\text{NaCO}_3$  is precipitated than can be leached out by groundwater flow (i.e., when evaporation is significant compared to groundwater flow). Alkali soils are thus associated with semi-arid and arid regions, and especially with irrigated land in these regions.

For a given soil type and climate, the concentration of  $\text{NaCO}_3$  in the soil is influenced by elevation, topography, vegetation, surface and subsurface drainage patterns, and depth to the water table.

#### SITE INVESTIGATION GOALS

- a) Confirm the presence of alkali soils and carbonate crust (through field testing, trenching and boring).



- b) Quantify the sodicity of the soils, to aid in mitigation planning (through sampling and laboratory testing).
- c) Assess potential for heave (through laboratory testing).

## **SITE INVESTIGATION ACTIONS**

### **Field Testing**

Field testing of pH, using a portable electronic potentiometer, allows for quick identification of alkali soils. Alkali soils have a pH greater than 8.5.

### **Trenching**

Trenching is performed to investigate the soil profile, including the depth, thickness and continuity of any carbonate crust. Alkali soil units can be identified in the field by testing their pH. Samples of alkali soils should be taken for laboratory analysis. Trench logs should be created.

### **Borings**

Borings serve to investigate the soil profile, and to obtain samples for laboratory analysis. Alkali soils can be identified by pH testing of soil cuttings.

The depth and spacing of borings depends largely on the planned works. Furthermore, it is likely that areas with different elevation, topography or vegetation will have different soil alkalinities; borings should be located to investigate the different areas of the site to a depth below that of planned works, or to the water table.

While borings may not be necessary for shallow works, they may be a more efficient method of investigation for a large site, given the potential for lateral variability of alkali soils.

### **Sampling**

Samples should be taken of all alkali soil units encountered in borings and trenches, and at regular depth intervals. Disturbed samples are sufficient for chemical analyses, undisturbed samples are necessary if swell tests are to be performed.

### **Laboratory Testing**

To quantify the sodicity of soils:

- Exchangeable Sodium Percentage (ESP) (USDA NRCS 4F3a)
- Sodium Adsorption Ratio (SAR) (USDA NRCS 4F3b)

To assess the swell potential of soils:

- One-dimensional swell test (ASTM D4546)

## **Interpretation of Laboratory Results**

### Sodicity

Soils are classified as alkali (also known as sodic) by an ESP of 15 or more, or a SAR of 13 or more. The U.S. Department of Agriculture has specified guidelines regarding the quantities of various remediation agents necessary to reduce the ESP to desired levels (Richards, 1954).

### Swell testing:

The findings of the one-dimensional oedometer swell test will indicate the swelling pressure (at constant volume) or volume change (under a constant confining pressure) produced by uptake of water. These findings should be related to the planned structural load to be applied to the soil and the thickness of swelling units. Caution should be taken when applying swell test results to the field; the tests are performed on small samples of soil and do not account for macro-structures in the subsurface, or environmental conditions.

## **POSSIBLE MITIGATION OPTIONS**

- Avoidance
- Treatment of soils with remediation agents to replace exchangeable sodium, best performed through excavation and mixing. Agents include gypsum, sulfur, lime-sulfur, iron sulfate and limestone. The choice of agent depends largely upon the natural carbonate content of the soil.
- Mixing of soils with, or replacement by, non-alkali material to reduce the overall alkalinity to acceptable levels.

## **RECOMMENDED AND CITED REFERENCES**

Food and Agriculture Organization of the United Nations (FAO), Soil Resources Management and Conservation Service. 1988. Sodic Soils and Their Management. *In* Saline Soils and Their Management. FAO Soils Bulletin 39. [www.fao.org/docrep/x5871e/x5871e00.htm](http://www.fao.org/docrep/x5871e/x5871e00.htm)

Gupta, I.C. and Gupta S.K. 2019. Crop Production in Salt Affected Soils. India: Scientific Publishers.

Richards, L.A. 1954. Diagnosis and improvement of Saline and Alkali Soils. U.S. Department of Agriculture, Handbook No. 60.

Sabatini, P.J., Bachus, R.C., Mayne, P.W., Schneider, J.A., and Zettler, T.E. 2002. Expansive Soils. *In* Geotechnical Engineering Circular No. 5: Evaluation of Soil and Rock Properties. (Section 7.3). U.S. Department of Transportation, Report No. FHWA-IF-02-034

Shahid, Shabbir A., Zaman, Mohammad, and Heng, Lee. 2018. Salinity and Sodicity Adaptation and Mitigation Options. In: Guideline for Salinity Assessment, Mitigation and Adaptation Using Nuclear and Related Technology, Springer, Cham. <https://doi.org/10.1007/978-3-319-96190-3>

UNESCO. 1973. Reclamation of saline and alkali soils. In: Irrigation, drainage and salinity: an international source book, FAO/UNESCO, 531 p.  
<https://unesdoc.unesco.org/ark:/48223/pf0000005717?posInSet=14&queryId=3f2fa233-444b-4e87-a5c4-0277499c4be4>

## 3.4 FROST ACTION

### THREATS POSED TO ENGINEERED WORKS

- Localized heaving of the ground surface during subsurface freezing
- Localized softening and deformation during subsurface thawing

### FIELD INDICATORS OF FROST ACTION

- Hummocky ground above growing ice lenses
- Heave damage to existing structures
- Angular fractured rock, due to freeze-thaw cycles
- Ice wedges extending into the subsurface
- Patterned (polygonal) ground in northern latitudes

### MECHANISMS OF FROST ACTION

Frost action involves two critical phases, the phase of subsurface freezing that may be accompanied by heaving of the ground surface, and the thawing phase that may be accompanied by softening of the subsurface material.

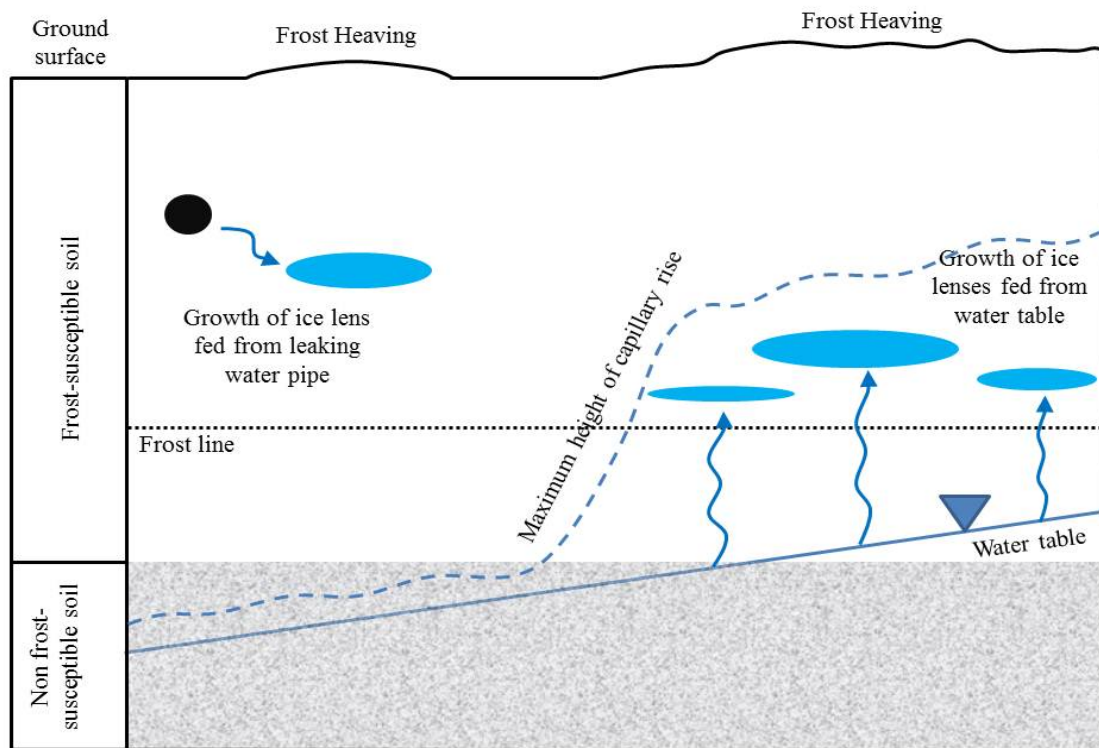
During the freezing phase, lenses of ice form within the frozen zone of the soil. If the lenses are fed by water they grow in the direction of heat loss (usually vertically) and may cause surface heaving and damage to rigid structures. The water source is usually the water table, via capillary action, but may also be surface infiltration or seepage from canals or leaking water pipes.

For frost action to develop where sources of free water do not exist, a continuous depth of frost susceptible soil must exist in the zone of capillary rise above the water table, as shown in Figure 3-5. Frost susceptible soils are those with porosity and grain size that promote capillary flow.

During the thawing phase, ice lenses become zones of excess liquid water, which causes a loss of soil strength and may allow plastic deformation.

### SITE INVESTIGATION GOALS

- a) Confirm that freezing temperatures exist in the soil, and determine the depth to which the frost line penetrates (through boring and the installation of frost tubes or thermocouples).
- b) Locate the water table, and identify possible sources of free water at the site (through installation of wells or piezometers, and site reconnaissance).
- c) Determine the types and depths of subsurface materials (through borings).
- d) Assess the frost susceptibility, frost heave potential and thaw weakening potential of soils (through sampling and laboratory testing).



**Figure 3-5** Subsurface conditions associated with frost heave. Ice lenses grow in the frozen zone of the soil if they are fed by water. Frost susceptible soils allow for the capillary rise of water to feed lens growth. Ice lenses can also be fed by free water in the subsurface, such as from leaking water pipes.

## SITE INVESTIGATION ACTIONS

### Borings

Borings in areas of possible frost action serve to confirm that freezing temperatures exist in the soil, to install frost tubes and/or thermocouples, to model the soil profile and to recover samples for laboratory analysis. The spacing of borings depends largely upon the nature of the planned works. Borings should be to the water table or the expected future water table if this is lower.

Frost penetration in uncompacted soil can be determined by boring into the soil, and noting the depth at which penetration resistance decreases (Jones et al., 1982). In compacted soils it may be difficult to identify such a drill break; in this case it is necessary to measure the temperature of soil cuttings at regular depth intervals, immediately after they reach the surface, to locate the transition to above-freezing temperatures.

### Frost Tubes and Thermocouples

The depth of the frost line can be monitored by the installation of a 'frost tube'. Frost tubes are of various designs; some provide real-time information of frost depth, others record the maximum depth of frost penetration over a given period. Thermocouples can also be installed at

depth intervals, in a back-filled hole, to monitor the temperature profile of the soil (Jones et al., 1982). Site investigation should take place during the winter months as this is when soil temperatures, and the frost line, are at their lowest.

### **Wells and Piezometers**

While ice lenses form above the frost line, they are usually fed by water from the water table. The water table can be located by sinking observation wells, or installing piezometers. It is worthwhile monitoring seasonal fluctuations in the water table.

The depth of the water table after construction, and during the lifespan, of the structure is very important. If this will be different to the present water table, this should be considered when assessing the soil profile and identifying potentially susceptible soils.

If free subsurface water exists close to the frost zone it may be incorporated into ice lenses. While the water table may be too far below the frost zone to act as a water source, seepage from nearby canals, surface run off, or leaking water pipes may act as localized sources.

### **Sampling**

When selecting soil units for investigation, it should be remembered that ice lenses will only form above the frost line and, if there is no source of free water, are restricted to the zone of capillary rise above the water table. This relationship is illustrated in Figure 3-5. Stratigraphic logs showing the frost line and the water table will aid in selecting soil units for further investigation. In general, finer grained soils support higher capillary rise, as summarized in Table 3-1.

Disturbed samples are sufficient for the assessment of frost susceptibility (by USCS classification and grain size analysis). Undisturbed samples are necessary for the testing of frost heave and thaw weakening susceptibility.

### **Laboratory Testing**

Assessment of frost susceptibility of soils by soil type (USCS classification) and grain size distribution:

- Particle size distribution (AASHTO T 88; ASTM D422)
- Liquid limit, plastic limit and plasticity index (AASHTO T 90; ASTM D4318)
- Classification of soils (USCS) (ASTM D2487)

Assessment of frost heave potential and thaw weakening potential:

- Frost Heave and Thaw Weakening Susceptibility of Soils (ASTM D5918)

**Table 3-1** Approximate height of capillary rise for broadly classified soil groups. Adapted from Jones et al. (1982).

Soil Type	Approximate Height of Capillary Rise	
	m	ft.
Coarse grained	0.1 – 1.5	0.3 – 5
Silt Varied silt and clay Silty, fine sand	1 - 5	3 - 16
Saturated, compressible clay	> 3	> 10

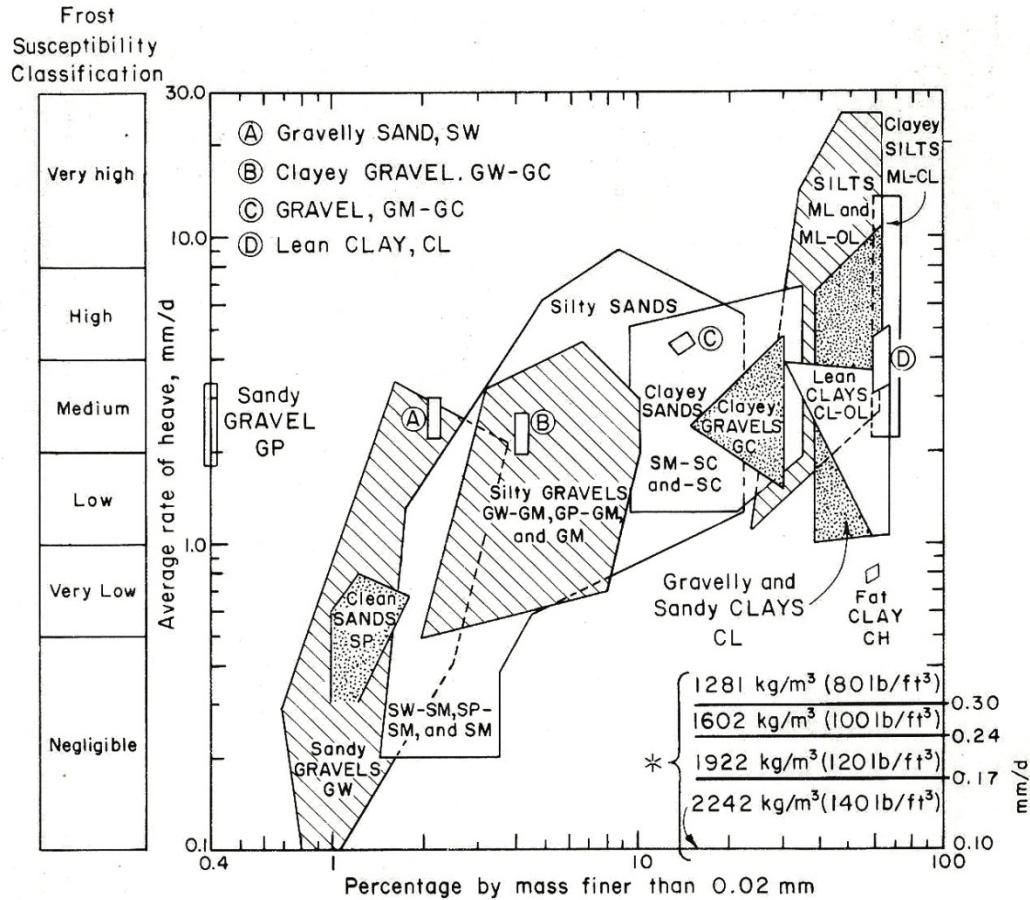
### Interpretation of Laboratory Results

Many schemes exist for the classification of soil frost susceptibility and prediction of potential frost heave. Perhaps the most widely used in the United States is that developed by the U.S. Army Corps of Engineers (1965), displayed in Figure 3-6.

Caution should be taken when applying the results of frost heave and thaw weakening tests to the field; the tests are performed on small samples of soil and do not account for macro-structures in the subsurface, or environmental conditions.

### POSSIBLE MITIGATION OPTIONS

- Replacement of frost susceptible soil within the frost zone with non-susceptible materials
- Restriction of the water supply to frost susceptible soils through drainage and a lowering of the water table. This approach does not always prevent frost heave, as soils often retain sufficient moisture to facilitate frost action
- Restriction of the water supply by emplacing an impermeable barrier below susceptible soils, or a layer of coarse grained material to prevent capillary rise – this layer should be thicker than the expected height of capillary rise within it
- Placement of thermal insulation such as coarse well-drained soils, plastic or glass foam above susceptible soils to inhibit the penetration of freezing temperatures
- Reducing the permeability of the susceptible soil by the addition of additives such as calcium chloride, lime, Portland cement or chemical dispersing agents



\* Indicated heave rate due to expansion in volume if all original water in 100 percent saturated specimen was frozen, with rate of frost penetration 6.35 mm (0.25-in) per day.

**Figure 3-6** Frost susceptibility classification and expected average rate of heave, based upon particle size distribution and soil type (USCS classification), modified from the US Army Corps of Engineers (1965). From Jones et al. (1982).

## RECOMMENDED AND CITED REFERENCES

Andersland, O.B. and Ladanyi, B. 2004. Frozen Ground Engineering, 2nd Ed. The American Society of Civil Engineers. Hoboken, New Jersey: John Wiley & Sons, Inc.

Chamberlain, E.J. 1982. Frost Susceptibility of Soil, Review of Index Tests. U.S. Department of Transportation, Report No. FHWA/RD-82/081.

Johnson, T. C., Berg, R. L., Chamberlain, E. J., and Cole, D. M. 1987. Frost Action Predictive Techniques for Roads and Airfields: Volume 1: A Comprehensive Survey of Research Findings, U.S. Department of Transportation, Report No. FHWA/RD-87/057.



Jones, C.W., Miedema, D.G., and Watkins, J.S. 1982. Frost action in Soil Foundations and Control of Surface Structure Heaving. U.S. Department of the Interior, Bureau of Reclamation, Report No. REC-ERC-82-17

Shoop, Sally A. ed. 2020. Frost Action in Soils: Fundamentals and Mitigation in a Changing Climate, American Society of Civil Engineers, 146p.

## 3.5 CARBONATE KARST

### THREATS POSED TO ENGINEERED WORKS

- Difficulties in predicting soil thickness over pinnacled bedrock
- Difficulties in excavation and grading over pinnacled bedrock
- Subsidence or collapse of soil cover over sinkholes
- Collapse of near-surface voids in the bedrock
- Difficulties in finding reliable foundation footings
- High drainage rates through the bedrock, affecting water storage and conveyance projects

### FIELD INDICATORS OF CARBONATE KARST

- Carbonate bedrock environment (caves and fissures)
- Chert and clay-rich residual soils
- Poorly developed surface drainage
- Closed surface depressions
- Springs and seeps

### MECHANISMS OF HAZARD DEVELOPMENT IN CARBONATE KARST

Carbonate rocks include limestone, dolomite, marble and chalk, all of which may be dissolved by water. Dissolution occurs on exposed rock surfaces, beneath the soil at the bedrock surface, or within the rock itself along discontinuities, as shown in Figure 3-7. The dissolution of bedrock forms karst features. Karst features pose a risk to engineered works through gradual or sudden loss of support, and complicate foundation designs. The rate of dissolution of carbonate bedrock is slow enough that the lowering of the bedrock surface itself does not pose a direct threat of subsidence. Of more importance are sinkholes, pinnacled bedrock surface and near-surface voids.

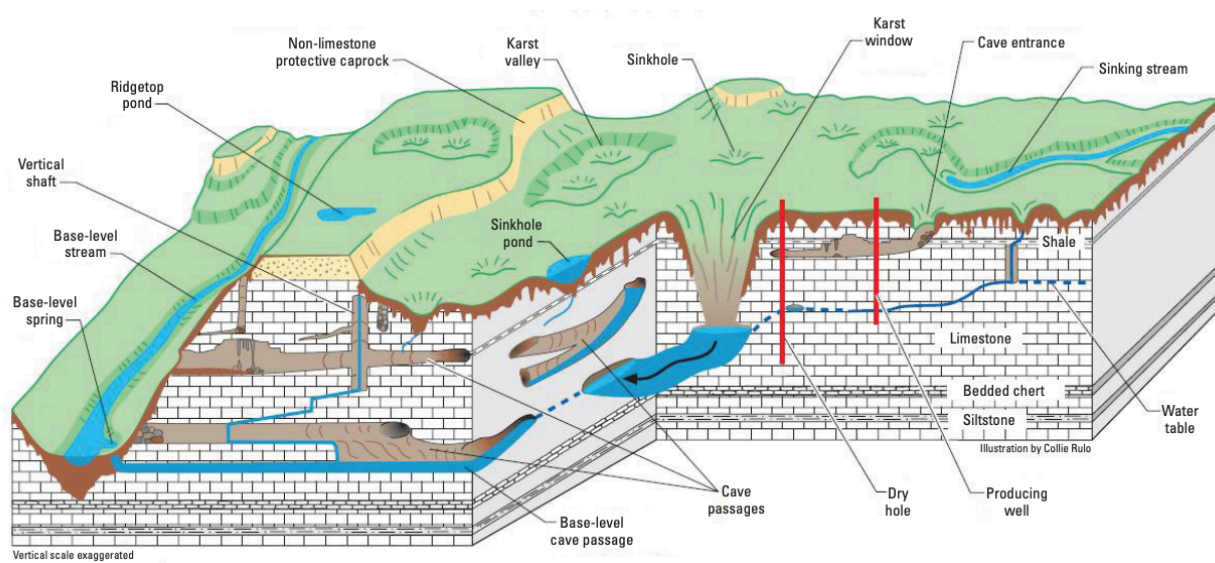
Sinkholes are closed surface depressions with underground drainage. Subsidence occurs as soils are removed through drainage pathways. Subsidence over sinkholes may be gradual or sudden, depending largely upon the cohesion of the soil cover. In general, sudden collapse is more likely to occur in cohesive soils where cavities are able to form, as illustrated in Figures 3-8 and 3-9. Sinkhole formation can be initiated by water table decline below bedrock surface, inducing material transport and removing buoyant forces from the overburden.

Pinnacled bedrock results from dissolution along inclined or vertical discontinuities to form unstable or loose blocks that may be supported only by soil, as shown in Figures 3-10 and 3-13. Pinnacled bedrock topography is notably unpredictable, with great variation in the depth and frequency of fissuring, the height and stability of buried pinnacles, and the size of loose blocks of rock. The presence of pinnacled bedrock complicates the prediction of soil thickness and the calculation of excavation volumes.

The size and shape of near-surface voids is highly variable, as shown in Figures 3-11 and 3-12. They occur along subsurface drainage pathways, may be fully or partially filled with sediment

and may collapse when their dimensions create unstable roof spans. If voids lie at sufficient depth, stable compression arches can develop within the rock roof. Of greater hazard to surface engineering are large voids at shallow depths, where they may threaten foundation integrity.

It is important to control subsurface drainage and groundwater levels in karst terrain. A lowering of the water table may enhance soil transport, accelerating the growth of existing sinkholes or forming new ones; it may also increase the effective weight of void overburden by the reduction of buoyant forces. The residual soils overlying limestone karst are usually clay-rich and often contain high concentrations of chert.



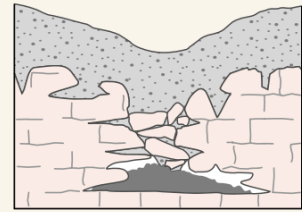
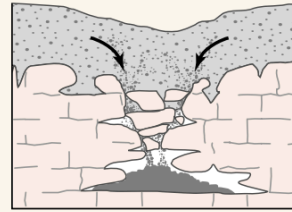
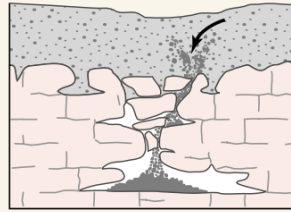
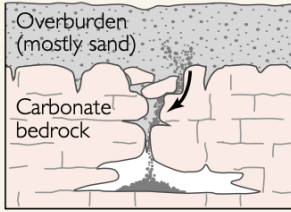
**Figure 3-7** Cross section through limestone showing underground drainage, sinkholes and pinnaced bedrock. From Taylor et al. (2014).

Granular sediments spall into secondary openings in the underlying carbonate rocks.

A column of overlying sediments settles into the vacated spaces (a process termed "piping").

Dissolution and infilling continue, forming a noticeable depression in the land surface.

The slow downward erosion eventually forms small surface depressions 1 inch to several feet in depth and diameter.

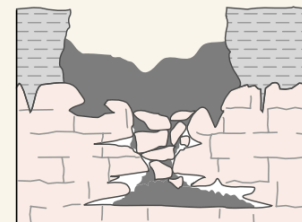
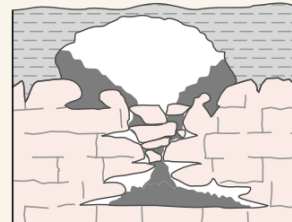
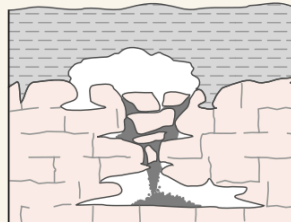
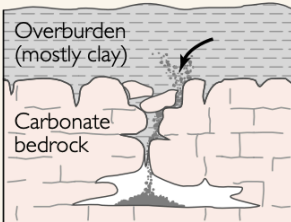


Sediments spall into a cavity.

As spalling continues, the cohesive covering sediments form a structural arch.

The cavity migrates upward by progressive roof collapse.

The cavity eventually breaches the ground surface, creating sudden and dramatic sinkholes.



**Figure 3-8** Cross section of sinkholes showing both gradual subsidence (Top) and sudden subsidence (Bottom). Sudden subsidence involves the collapse of a void in the surficial cover and is most common in cohesive soils. From Galloway et al. (1999).

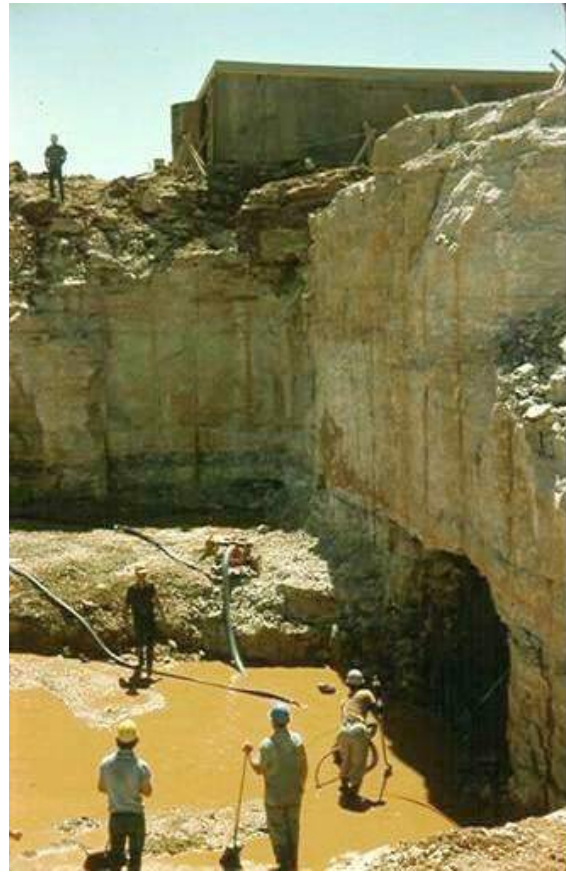


**Figure 3-9** Surface collapse of cohesive soils above a sinkhole in Winter Park, Florida. Note vehicles in the foreground for scale. From <https://www.usgs.gov/media/images/winter-park-florida-sinkhole-1981-12>





**Figure 3-10** Pinnacled bedrock. Top: highly developed, exposed on a construction site in China. From Waltham and Fookes (2005); Bottom: moderately developed, exposed in a 6 metre roadcut. Courtesy of J. Higgins, Colorado School of Mines.



**Figure 3-11** Cave beneath a construction site near Springfield, Missouri. Courtesy of J. Higgins, Colorado School of Mines.



**Figure 3-12** Solution features exposed during earthworks for the Clarence Cannon Dam, central Missouri. Courtesy of J. Higgins, Colorado School of Mines.

## **SITE INVESTIGATION GOALS**

The potential for serious geological hazards, combined with the inherent unpredictability and lack of spatial uniformity of karst features, demands an extensive and comprehensive site investigation. It is highly recommended that personnel experienced in karstic investigation and engineering be involved in this phase.

The goals of the site investigation are to:

- a) Review existing information of geology, hydrology and engineering history.
- b) Assess rock mass structure, and the state and variability of the bedrock surface (through outcrop study and trenching).
- c) Identify possible sinkholes and voids (through geophysical methods).
- d) Assess depth to bedrock, bedrock integrity and rock mass structure, and investigate possible sinkhole and void locations (through boring).
- e) Characterize groundwater conditions (through wells, piezometers and existing data).
- f) Characterize existing surface drainage patterns (through site reconnaissance).
- g) Assess soil and rock engineering properties (through sampling and laboratory testing).

For lightly loaded structures designed with shallow foundations, the investigation and characterization of bedrock and bedrock voids may be of lesser importance than that of soils.

## **SITE INVESTIGATION ACTIONS**

### **Preliminary Information Review**

The following information should be reviewed; it will provide a starting point for the subsequent site investigation.

- USGS Groundwater Information Pages to locate known karstic aquifers in the region
- Geologic maps to locate carbonate bedrock
- USGS national karst map to evaluate if carbonates in the region may be karst prone (Weary and Doctor, 2014)
- Topographic maps and aerial photos (best viewed stereoscopically), or Google Earth or other internet or printed aerial photographs, to identify depressions, possible sinkholes and unusual surface drainage patterns
- Hydrogeologic reports for expected water table depths and fluctuations
- Existing investigation reports for areas on, or close to, the site
- Existing investigation reports from areas with similar geology, topography and climate
- Local media reports on sinkhole occurrences
- Interviews with persons familiar with the site

### **Trenching and Outcrop Study**

Trenching and outcrop study in karst terrain is performed to assess bedrock structure, the degree of weathering and the variability of the bedrock surface, and the soil profile. The spacing and

orientation of rock mass discontinuities should be recorded for rock mass classification, soil types and depths should be noted, and soil samples taken for laboratory analysis. Trenching provides good, detailed information but can be difficult over pinnacled bedrock.

### Geophysical Investigation

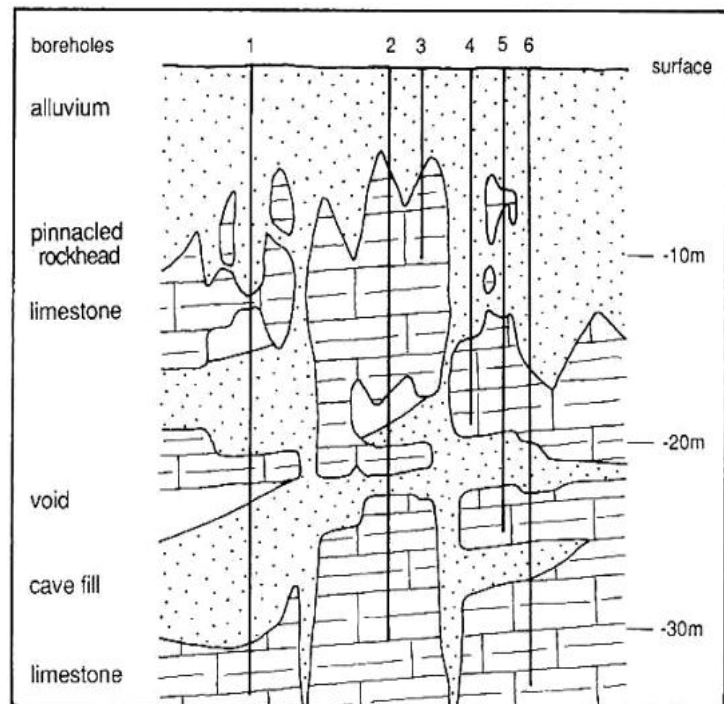
Geophysical exploration in karst terrain aims to locate geophysical anomalies that may be sinkholes or subsurface voids. Techniques may include mechanical waves, seismic reflection and refraction, resistivity, microgravity, magnetic surveying and ground-penetrating radar. Geophysical techniques can provide useful information but their degree of reliability is variable. Findings from geophysical investigations should serve as a guide for the boring investigation, from which they can be validated (Waltham and Fookes, 2005).

### Borings

A boring plan should be designed to locate the bedrock surface, assess bedrock integrity, locate voids and obtain samples for RQD and laboratory analysis. The boring plan should be guided in part by the findings of the geophysical investigation. Suspected voids, sinkholes and potential foundation locations should be targeted.

It is important to note that sound bedrock may not be easy to locate with complete certainty, especially in highly developed karst terrain, as illustrated by Figure 3-13. It should not be assumed that encountered rock is part of the bedrock mass, rather, the opposite should be assumed until deeper exploration indicates otherwise.

Rotary drilling methods may be used to locate rock contacts; intact rock cores are required for RQD analysis and laboratory sampling; oriented cores are required for the assessment of rock mass structure.



**Figure 3-13** Cross section of exploratory borings in highly developed karst in Kuala Lumpur, Malaysia. Note borings 3, 4 and 5 which independently appear to have reached bedrock. From Waltham (2002).

## **Groundwater Study**

It is important to locate the water table and to monitor its fluctuation, through the installation of piezometers and/or observation wells, and with the aid of data from nearby existing wells.

## **Surface Drainage Study**

It is important to identify surface drainage patterns on the site, and to assess how the planned works may affect these patterns. Drainage through sinkholes may inadvertently become clogged by grading or by excess erosion, causing surface flooding if no alternative drainage is developed. Sinkholes may be stabilized to maintain local subsurface drainage. Drainage directed off-site will affect the adjacent drainage systems.

## **Sampling**

Beyond standard sampling procedures, the focus of the sampling plan depends upon the nature of the subsurface and the planned work. For an abundance of empty voids or foundations anchored on rock the sampling and analysis of the relevant rock is of importance. For an abundance of soil-filled voids or foundations anchored in soils the sampling and analysis of the relevant soils is important.

For rock sampling, cores should be retrieved to enable rock classification, RQD, and to record discontinuities. The rock mass can be separated into zones of similar quality or expected behavior based upon this information. For each rock zone samples should be taken for laboratory analysis.

For soil sampling, disturbed or undisturbed samples should be collected depending upon the required laboratory tests.

## **Laboratory Testing**

Laboratory tests of soil and rock engineering properties should be selected based upon the nature of the planned works. For foundations anchored in soils, the engineering properties of the soils may be of more importance than those of the rock mass. For foundations anchored on bedrock, the engineering properties of the rock mass may be of more importance than those of the soils.

## **Rock Mass Properties**

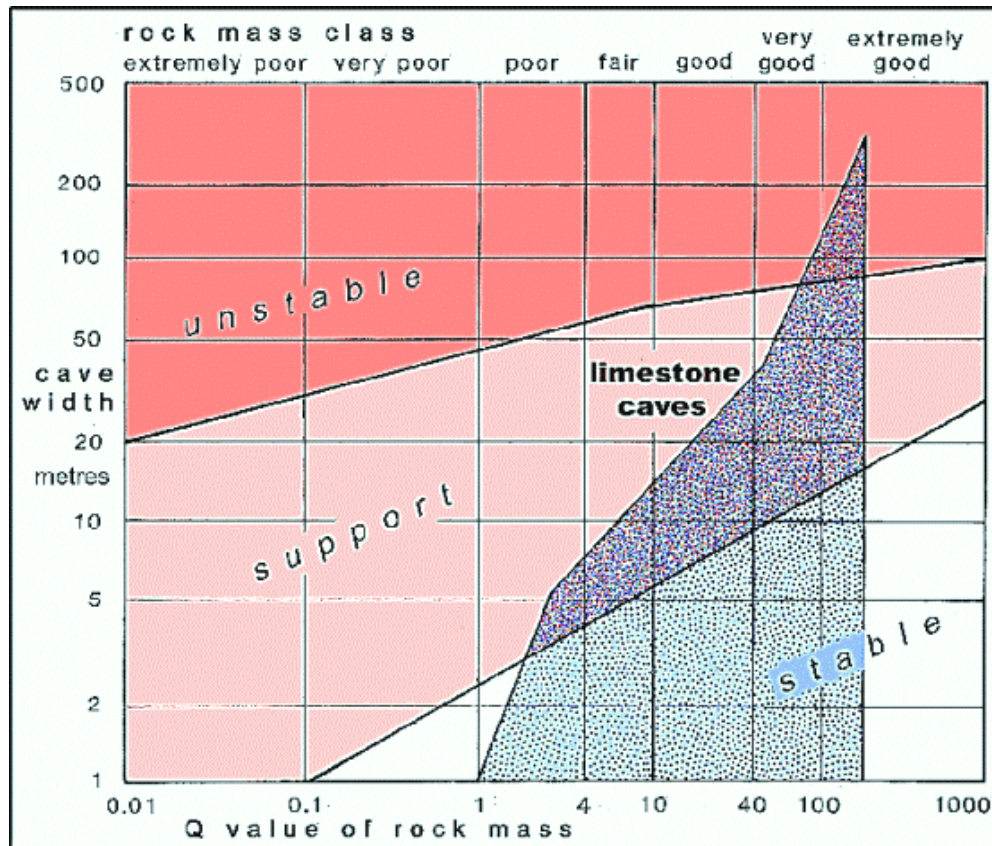
The properties of the rock mass are important in karst terrains, especially for the assessment of void stability. Rock mass properties are evaluated from intact rock properties and field observations of discontinuities, groundwater conditions and RQD. Several rock mass classification schemes exist, suited to various engineering works:

- The Rock Mass Rating System (RMR), for mining, tunneling and cut-slope applications (Bieniawski, 1989)
- The Norwegian Geotechnical Institute–Q Rating, for tunneling applications (NGI, 2015)



- The Geological Strength Index (GSI), for strength and stiffness of intact and fractured rock (Hoek and Brown, 2019)

Several empirical guides have been developed that relate rock mass classifications to void size and stability, an example is shown in Figure 3-14.



**Figure 3-14** Cave stability related to cave width and rock mass quality (Q, after Barton et al., 1974). The envelope of limestone caves (stippled) is derived from observations of limestone caves around the world. The labeled fields of stability are those applied in guidelines for the Norwegian Tunneling Method and are conservative in relation to natural caves. From Waltham and Fookes (2005).

## POSSIBLE MITIGATION OPTIONS

Site preparation:

- Excavation of topmost levels of pinnacled bedrock
- Excavation and sealing of sinkholes to mitigate subsurface drainage
- Emplacement of lined ditches to accommodate surface drainage
- Excavation and filling of sinkholes with graded fill to allow subsurface drainage without loss of soil

Foundation design:

- Rafts, rock pads or grade beams to bridge depressions and sinkholes
- Grouting of weathered rock, fissures or voids
- Drilled shafts (driven piles may be doglegged)
- Sacrificial supports

## RECOMMENDED AND CITED REFERENCES

Bieniawski, Z.T. 1989. *Engineering rock mass classifications: a complete manual for engineers and geologists in mining, civil, and petroleum engineering*. New York: Wiley. 251p.

Galloway, D., Jones, D.R., and Ingebritsen, S.E. 1999. Land Subsidence in the United States. USGS Circular 1182, 177p. Available from: <https://pubs.usgs.gov/circ/circ1182/#pdf>.

Goodman, R.E. 1993. Soluble Rocks: Limestone, Dolomite and Evaporites. *In Engineering Geology: Rock in Engineering Construction* (Chapter 5). John Wiley and Sons.

Gouzie, D. and Pendergrass, G. 2009. Investigation and Remediation of the 2006 Nixa, Missouri, Collapse Sinkhole. *Environmental and Engineering Geoscience*, Vol. XV, No. 1, February 2009, pp. 13-27.

Hoek, E. and Brown, E.T. 2019. The Hoek-Brown failure criterion and GSI – 2018 edition. *Journal of Rock Mechanics and Geotechnical Engineering*, Vol. 11, No. 3, pp. 445-463.

Moore, H.L. 2006. A Proactive Approach to Planning and Designing Highways in East Tennessee Karst. *Environmental and Engineering Geoscience*, Vol. XII, No. 2, pp. 147-160.

NGI. 2015. Using the Q-system: Rock mass classification and support design. Oslo: Norwegian Geotechnical Institute, 56 p, [electronic document]. Available from: <https://www.ngi.no/eng/Services/Technical-expertise/Engineering-geology-and-rock-mechanics/Q-system>

Taylor, Charles J. and Greene, Earl A. 2014. Hydrogeologic Characterization and Methods Used in the Investigation of Karst Hydrology, In: *Field Techniques for Estimating Water Fluxes Between Surface Water and Ground Water*, Donald O. Roosenberry and James W. LaBaugh, eds. US Department of the Interior, USGS, Techniques and Methods 4-D2. Available from: <https://pubs.usgs.gov/tm/04d02/pdf/TM4-D2-chap3.pdf>

Waltham, T. 2002. Subsidence on Limestone. *In Foundations of Engineering Geology*, 2 Ed (Chapter 29). Spon Press.

Waltham, Tony. 2012. "Chapter 38: Soluble Ground." In *ICE Manual of Geotechnical Engineering, Volume 1 - Geotechnical Engineering Principles, Problematic Soils and Site Investigation*, John Burland, Tim Chapman, Hilary Skinner, and Michael Brown eds. London: ICE Publishing.

Waltham, A.C., and Fookes, P.G. 2005. Engineering Classification of Karst Ground Conditions. *Speleogenesis and Evolution of Karst Aquifers*, Vol. 3, No. 1, pp. 1-20.

Weary, David J. and Doctor, Daniel H. 2014. Karst in the United States: A Digital Map Compilation and Database. U.S. Geological Survey Open-File Report 2014-1156, 23p. <https://dx.doi.org/10.3133/ofr20141156>.

Xeidakis, G.S., Torok, A., Skias, S., and Kleb, B. 2004. Engineering Geologic Problems Associated with Karst Terrains: Their Investigation, Monitoring and Mitigation, and Design of Engineering Structures on Karst Terrains. *Bulletin of the Geological Society of Greece XXXVI*, pp. 1932-1941.

## 3.6 EVAPORITE KARST

### THREATS POSED TO ENGINEERED WORKS

- Subsidence or collapse of soil cover over voids in soil or bedrock
- Lateral variability of subsurface materials across subsidence and collapse features
- High drainage rates through bedrock, affecting water storage and conveyance projects

### FIELD INDICATORS OF EVAPORITE KARST

- Cavities (vugs) and distorted bedding in bedrock
- Subsidence bowls
- Vegetation is often sparse in evaporite soils
- ‘Popcorn’ texture of soils at surface
- Poorly developed surface drainage
- Springs and seeps

### ENGINEERING CHARACTERISTICS OF EVAPORITE KARST

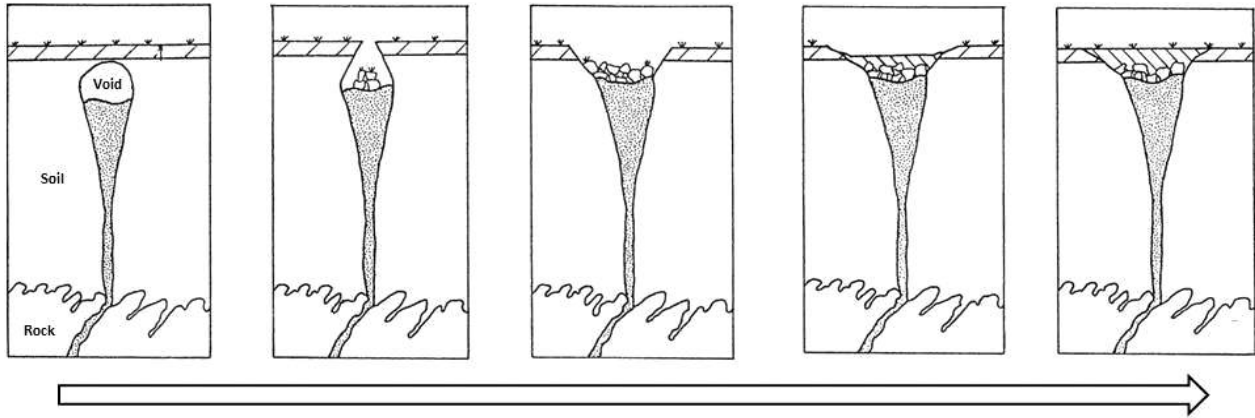
Evaporite rocks include gypsum, anhydrite and halite. Evaporite rocks, and soils derived from them, are subject to dissolution weathering. Due to the speed of evaporite dissolution, the associated volume changes in bedrock and soils can be significant over the lifespan of an engineered structure. Karst features associated with evaporite environments are subsurface voids, sinkholes and breccia pipes. Hazards associated with these environments are subsidence or collapse of the ground surface, and difficulty in finding reliable foundation footings.

The dissolution of evaporite bedrock forms fissures and voids along paths of water transport. Differential subsidence may occur as soils ravel through drainage pathways. Surface collapse may also occur when the ravelling of soils forms an upward-stoping cavity, as shown in Figures 3-15, 3-16, 3-17.

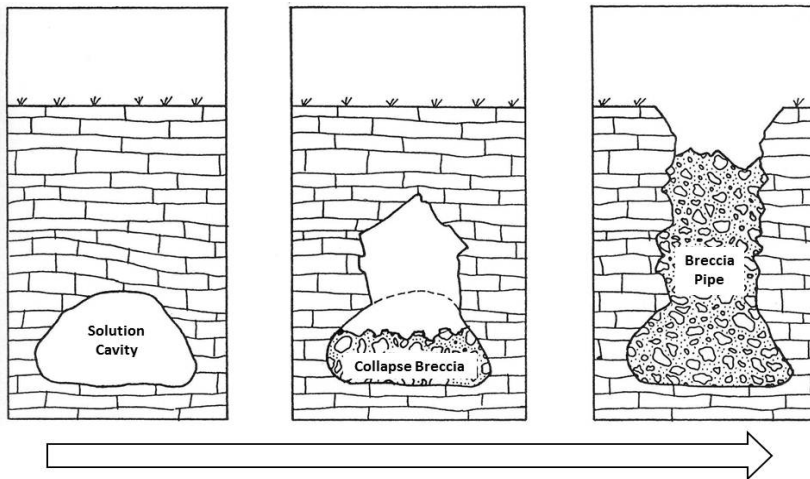
Evaporite rock is of relatively low strength and does not support the formation of large empty voids. The upward-stoping collapse of a bedrock void forms a breccia pipe, eventually resulting in surface collapse and subsidence, as illustrated in Figure 3-16.

Soils derived from evaporite rock are prone to settlement, and possibly collapse, when wetted. Refer to sections on saline soils (Section 3.13) and gypsiferous soils (Section 3.14) for guidelines on hazard assessment in evaporite soils.

It is important to control subsurface drainage and groundwater levels in evaporite terrain. Increases in subsurface drainage may exacerbate bedrock dissolution, inducing the formation of sinkholes. Decline in groundwater levels may induce soil raveling and the formation of sinkholes, and may also induce the collapse of existing voids as buoyant forces are removed.



**Figure 3-15** Cross sections through evaporite bedrock and soil cover showing the progressive formation of a sinkhole. Transport of soil into the fissured bedrock forms an upward-stoping void, resulting in surface collapse. Over time the collapse structure is filled with sediment and may become difficult to identify. Modified from Mock (2002).



**Figure 3-16** Cross sections through evaporite bedrock illustrating the progressive formation of a breccia pipe. Evaporite bedrock does not support the formation of large voids. The progressive collapse of the void roof propagates the cavity toward the surface, leaving a pipe of brecciated rock material in its path. Modified from Mock (2002).

## SITE INVESTIGATION GOALS

Site investigation goals and actions depend largely upon the planned works. For important structures such as bridge abutments, it may be necessary to fully characterize the site, identifying all voids and sinkholes. For less sensitive structures such as roadways it may be more economical to incorporate subsidence mitigation into design, rather than locate and stabilize all voids and sinkholes beneath the route.

It can be difficult and costly to locate all the bedrock voids, fissures and sinkholes within a large area. In areas that experience considerable underground drainage, voids and fissures are likely to be more numerous and more difficult to stabilize. In such environments it is also likely that existing voids and fissures will enlarge, and new sinkholes will form, over the lifespan of the engineered structure.



**Figure 3-17** Surface collapse features above evaporite sinkholes near Glenwood Springs, CO. In this case, irrigation has exacerbated the dissolution of underlying evaporite bedrock, inducing the formation of sinkholes. For scale, note the vehicle in the depression on the left (From Lovekin and Higgins, 2003).

The aims of the site investigation are to:

- a) Review existing information of geology, hydrology and engineering history
- b) Locate possible voids, sinkholes and breccia pipes (through geophysics, trenching and boring)
- c) Assess rock mass structure (through outcrop study and trenching)
- d) Assess rock engineering properties (through sampling and lab testing)
- e) Characterize groundwater conditions (through wells, piezometers and existing data)
- f) Characterize surface drainage patterns (through site reconnaissance)

## **SITE INVESTIGATION ACTIONS**

### **Preliminary Information Review**

The following information should be reviewed; it will provide a starting point for the subsequent site investigation.

- Geologic maps to locate evaporite bedrock
- Topographic maps and aerial photos (best viewed stereoscopically) or Google Earth or other internet or printed aerial photos to identify depressions, possible sinkholes and unusual surface drainage patterns
- Hydrogeologic reports for expected water table depths and fluctuations
- Existing investigation reports for areas close to the site
- Existing investigation reports from areas with similar geology, topography and climate
- Local media reports on sinkhole occurrences
- Interviews with persons familiar with the site

## **Geophysical Exploration**

Exploratory drill holes may easily miss subsurface voids and fissures. Geophysical exploration can identify anomalies that may be voids, fissures, sinkholes or breccia pipes (Cooper and Calow, 1998; Cooper, 1998). Geophysical exploration is perhaps most efficient and of most value when started from, and used to extend, existing borehole data. Anomalies identified by geophysics should be the focus of investigative drilling.

Since evaporite rocks are relatively soft and low density, and the voids within them are relatively small; it can be difficult to detect cavities. Geophysical techniques that have been applied in evaporite karst include resistivity tomography, microgravity, and ground-penetrating radar.

## **Outcrop Study**

Where evaporite rocks outcrop, it is likely that they will be highly weathered and not wholly representative of the rock mass at depth. However, discontinuity orientations can be assessed in outcrops and, combined with information of the rock at depth, may be useful in the design of foundations.

## **Trenching**

Trenching in evaporite terrain allows study of the bedrock surface, to assess rock mass structure and the degree of weathering of the bedrock surface. Trenching for these purposes is only feasible if the bedrock surface is within a few meters of the ground surface. The spacing and orientation of discontinuities should be assessed, and the size and abundance of solution weathering features (such as fissures) noted. Trenching also allows for study of the soil overburden, and the collection of soil samples.

## **Borings**

The purpose of borings in evaporite terrain is to locate the bedrock surface, assess bedrock integrity, locate voids and obtain samples for laboratory analysis. Suspected voids, sinkholes, breccia pipes and proposed foundation locations should be targeted. If geophysical surveys have been conducted, their findings can be used to guide the boring exploration.

Destructive drilling methods may be used to locate rock contacts and voids. Intact rock cores are required for laboratory sampling.

## **Sampling**

Rock cores should be retrieved to enable rock classification, and to provide samples for laboratory analysis. The rock mass can be separated into zones of similar quality or expected behavior, based upon the logging of cores. For each rock zone, representative samples should be taken for laboratory analysis.



## **Laboratory Testing**

Laboratory tests of rock engineering properties should be selected based upon the nature of the planned works. For foundations anchored in soils, the engineering properties of the rock mass may not be of great importance. For foundations anchored on bedrock, the engineering properties of the rock mass are of great importance.

## **Groundwater Study**

It is important to locate the water table and to monitor its fluctuation, through the installation of piezometers and/or observation wells, and with the aid of data from nearby existing wells.

## **Surface Drainage Study**

Existing drainage patterns in the area of the site should be studied and understood. The impact of the planned works on existing drainage patterns should be assessed. If water is allowed to drain freely through the subsurface; soil dissolution and sinkhole development may progress within the lifespan of the engineered works.

## **POSSIBLE MITIGATION OPTIONS**

In all karst environments the control of drainage into the subsurface, and the maintenance of the water table are essential. The selection of mitigation methods is largely dependent upon the nature of the planned works.

Site preparation:

- Excavation and sealing of sinkholes to minimize subsurface drainage
- Emplacement of impermeable surface drainage facilities, to accommodate surface drainage and reduce infiltration into the subsurface

Foundation design:

- Rafts, rock pads or grade beams to bridge depressions and sinkholes
- Grouting of voids and fissures with sulfate-resistant grout. It should be noted that, if drainage is not controlled, grouting may simply exacerbate dissolution of adjacent rock.
- Drilled shafts (driven piles may be doglegged)
- Sacrificial supports
- Layers of high-tensile 'geo-grid' in road sub-base or embankments to mitigate collapse event

## **RECOMMENDED AND CITED REFERENCES**

Cooper, A.H. 1998. Subsidence Hazards Caused by the Dissolution of Permian Gypsum in England: Geology, Investigation and Remediation. *In* Maund, J.G. and Eddleston, M. (Eds.), *Geohazards in Engineering Geology. Engineering Geology Special Publications*, Vol. 15. Geological Society, London. pp. 265-275.



Cooper, A.H. and Calow, R.C. 1998. Avoiding Gypsum Geohazards: Guidance for Planning and Construction. British geological Survey (BGS) Technical Report WC/98/5.

Cooper, A.H., Gutiérrez, F., 2013. Dealing with gypsum karst problems: hazards, environmental issues, and planning. In: Shroder, J. (Editor in Chief), Frumkin, A. (Ed.), *Treatise on Geomorphology*. Academic Press, San Diego, CA, vol. 6, Karst Geomorphology, pp. 451–462. Available from: <https://core.ac.uk/download/pdf/17201109.pdf?repositoryId=79>

Cooper, A.H., and Saunders, J.M. 2002. Road and Bridge Construction across Gypsum Karst in England. *Engineering Geology*, Vol. 65 (2002), pp. 217-223.

Guerrero, J., Gutierrez, F., and Lucha, P. 2003. Paleosubsidence and Active Subsidence due to Evaporite Dissolution in the Zaragoza area (Huerva River Valley, NE Spain): Processes, Spatial Distribution and Protection Measures for Transport Routes. *Engineering Geology*, Vol. 72 (2004), pp. 309-329.

Gutierrez, F., Cooper, A.H., and Johnson, K.S. 2008. Identification, Prediction and Mitigation of Sinkhole Hazards in Evaporite Karst Areas. *Environmental Geology*, Vol. 53, pp. 1007-1022.

Lovekin, J.R., and Higgins, J.D. 2003. Major Geologic Hazards along the Roaring Fork River near Glenwood Springs, Colorado. Association of Engineering Geologists, Special Publication 15 (2003).

Mock, R.G. 2002. Geologic Setting, Character, and Potential Hazards for Evaporite-Related Sinkholes in Eagle and Garfield Counties, Northwestern Colorado. Geological Society of America Special Papers (2002), Vol. 366, pp. 157-166.

Waltham, Tony. 2012. “Chapter 38: Soluble Ground.” In *ICE Manual of Geotechnical Engineering, Volume 1 - Geotechnical Engineering Principles, Problematic Soils and Site Investigation*, John Burland, Tim Chapman, Hilary Skinner, and Michael Brown eds. London: ICE Publishing.

Weary, David J. and Doctor, Daniel H. 2014. Karst in the United States: A Digital Map Compilation and Database. U.S. Geological Survey Open-File Report 2014-1156, 23p. <https://dx.doi.org/10.3133/ofr20141156>.

## 3.7 SUBSIDENCE DUE TO UNDERGROUND MINING

### THREATS POSED TO ENGINEERED WORKS

- Differential settlement and grade altering of the ground surface
- Surface collapse above voids
- Lateral strains of the ground surface

### IDENTIFYING SITES THAT ARE UNDERLAIN BY MINES

Mining activities in the U.S. are well documented and records have been compiled by the National Mine Map Repository (NMMR), part of the U.S. Department of the Interior's Office of Surface Mining. NMMR resources are accessible online.

### METHODS OF UNDERGROUND MINING

Underground mining in the United States has predominantly been for bedded resources such as coal, salt, potash, gypsum and sulfur. Such deposits occur in generally planar seams within the bedrock, and have been mined by longwall, room and pillar or solution methods.

#### Longwall Mining

During longwall mining the seam is mined by a cutting machine that travels back and forth across its face. The roof is allowed to collapse as the machine advances. Surface effects of longwall mining result from the propagation of a 'subsidence wave' which causes surface tilting and the formation of a subsidence trough, compression ridges and tension cracks and fissures, as illustrated in Figure 3-18. Most subsidence occurs within days of extraction but residual subsidence may occur for several months to a year after the end of extraction.

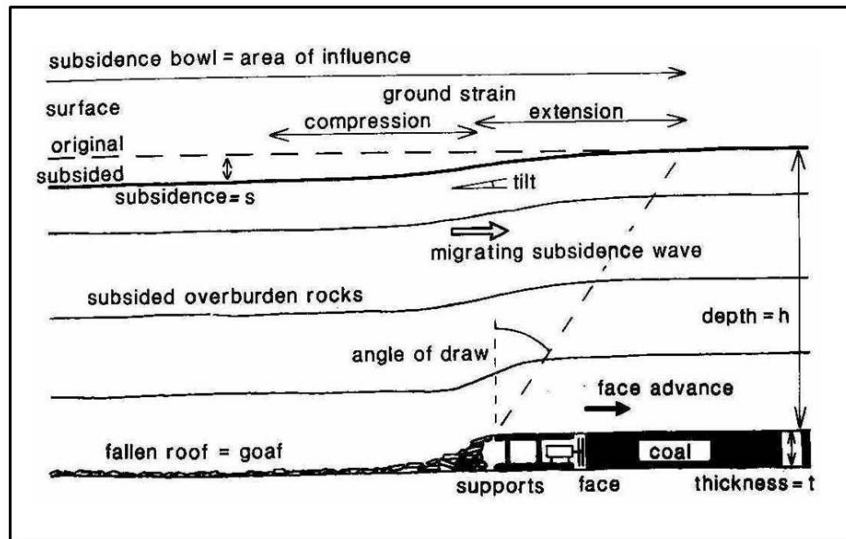
#### Room and Pillar Mining

During room and pillar mining some of the seam is left intact as pillars to support the roof. During the final stages of mining pillars may be partially or fully removed. Due to multiple stages of removal and the slow deformation and deterioration of pillars, surface settlement is rarely uniform, difficult to predict and may continue or be delayed for years. Surface features of room and pillar subsidence include pits, troughs and depressions, compression ridges, tension cracks and fissures. Some of these features are shown in Figure 3-19.

#### Solution Mining

Solution mining is most often associated with the injection of water to dissolve salts such as halite, potash and sodium sulfate, which are separated from the solvent upon retrieval. Solution mining produces cavities in the subsurface. The size, shape and distribution of cavities are largely dependent upon the character of the deposit and locations of the injection and extraction wells. The prediction of solution cavity collapse is very difficult due to the plastic nature of salt

deposits and the potential for continuing enlargement of these cavities after mining has ceased, through natural hydrologic processes.



**Figure 3-18** Cross section of an advancing longwall face. The subsidence wave migrates with the advance of the fallen roof. Note the angle of draw (controlled by the strength and structure of the overburden) relating the limit of the collapsed roof to the limit of the subsidence bowl. Note the compressional and extensional ground strain. From Waltham (1989).



**Figure 3-19** June 25<sup>th</sup> 2017 satellite image of room and pillar mine subsidence near Sheridan, Wyoming, above the Old Monarch Mine in operation from 1904 to 1921. Overburden thickness is estimated to be 10 to 15 meters. Circular pits and depressions are from roof collapse between pillars. Smaller holes are caused by piping failure as surface water drains into tensional cracks. Image taken from Google Earth.

## **CONTROLS AND LIKELIHOOD OF SUBSIDENCE**

The nature and timing of subsidence above underground mines is influenced by a number of factors including:

- Thickness of the mined seam and the amount of material extracted
- Orientation of the seam
- Strength and spacing of pillars or roof support
- Depth, strength and structural soundness of the overburden
- Hydrogeologic environment

The Manual for Abandoned Underground Mine Inventory and Risk Assessment (Ruegsegger, 1998) presents a system for evaluating the relative risk of subsidence over abandoned mines, based on a points rating. While this system does not apply to assessment of a single site, several of the criteria used are good indicators of the potential for subsidence:

- Evidence of surface deformation – If subsidence has already occurred at a site, it is highly possible that more subsidence may occur.
- Ratio of unconsolidated materials to bedrock in the overburden interval – Subsidence potential is greater for sites where a larger portion of the overburden is comprised of unconsolidated materials.
- Type, condition and thickness of bedrock in the overburden – Harder, more competent bedrock in thicker units can more effectively bridge voids and prevent subsidence
- Hydrogeologic environment – Mines that have been dewatered are less stable than those that are flooded, which in turn are less stable than mines that have some minimal amount of groundwater storage and movement within them.
- Minimum overburden thickness – A greater overburden thickness reduces the potential for subsidence.
- Maximum mined seam thickness – A greater mined seam thickness increases the potential for subsidence.
- Secondary mining – Such activities indicate that large areas of unsupported mine roof may exist (removal of pillars), thus increasing the potential for collapse and subsidence.

## **PREDICTION OF SUBSIDENCE**

Numerous methods exist for predicting ground subsidence and lateral displacement, including empirical, influence function and theoretical model methods. Each method of calculation may yield good results if its parameters are correctly selected.

Subsidence due to longwall mining can be predicted relatively accurately. Subsidence due to room and pillar mining is far more difficult to predict, especially above older mines where rooms, pillars and panels are non-uniform, and where pillars may have been deformed or punched through the mine roof. Subsidence due to solution mining is equally difficult to predict, especially above older mines in which deformation of soft bedrock and enlargement of cavities is likely to have occurred. In such cases the prediction of time and severity of subsidence is widely considered to be unreliable.

Since subsidence due to longwall mining is largely complete within days of extraction, the greater threat to engineered works is subsidence over abandoned room and pillar mines and solution cavities. Deterioration of roof support, soft-rock deformation, changes in groundwater levels, raveling of soils and natural enlargement of cavities can all initiate collapse and subsidence, as can seismic shaking, vibration, and surface loading,

## **SITE INVESTIGATION GOALS**

The lack of predictability of subsidence over room and pillar mines or solution cavities is best addressed by avoiding development of sites above such mines. If avoidance is not an option it should be assumed that subsidence may occur, and site investigations should be directed toward the selection of subsidence prevention or mitigation techniques.

- a) Determine the mining history of the site and obtain detailed information for any existing mines (through the NMMR)
- b) Determine the groundwater level beneath the site, and within the underground mine (through the installation of wells)
- c) Locate and characterize voids beneath the site (through the NMMR, geophysical methods and boring)
- d) Determine the type and condition of the overburden above voids (through boring)

## **SITE INVESTIGATION ACTIONS**

### **The National Mine Map Repository (NMMR)**

The purpose of researching the NMMR is to establish if underground mines exist beneath the proposed site, and to obtain as much information of the mine works and overburden geology as possible. NMMR information of mine works and geology should be verified from other sources before use. NMMR records include:

- Mine plans including mains, rooms, and pillars
- Closure maps
- Man-ways, shafts, mine surface openings
- Geological information including bed name, bed thickness, depth, drill-hole data, cross-sections, elevation contours and structures.

### **Wells**

The purpose of installing wells beneath the site is to determine the locations and levels of groundwater beneath the site and within the mine. This knowledge is important in anticipating how boring operations will affect water levels within voids, and in the selection of method(s) for subsidence prevention or mitigation. Groundwater levels should be monitored throughout investigation and construction operations.

Mines that have been dewatered are less stable than those that are flooded. If the mine is underlain by impermeable rock, groundwater within the mine may be 'perched'. In such a

scenario it is possible that drilling through the impermeable layer will cause a dewatering event that may lead to void collapse. Conversely, if the mine is overlain by impermeable rock, drilling through this layer may cause a flooding event that will affect remediation operations.

## **Geophysical Exploration**

The purpose of geophysical exploration above underground mines is to locate and characterize subsurface voids, in order to select the best method(s) of subsidence prevention or mitigation. The present condition of mine voids may be highly variable due to varying degrees of roof collapse, pillar failure and punching, and floor heave. Mine chambers that were once continuous may now be highly compartmentalized.

Geophysical techniques may include mechanical waves, seismic reflection and refraction, resistivity, microgravity, magnetic surveying and ground-penetrating radar. These techniques can provide useful information but their degree of reliability is variable. Findings from geophysical investigations should be compared to the mine information obtained from the NMMR and serve as a basis for boring investigations, from which they can be validated.

## **Borings**

The purpose of borings above underground mines is to locate and characterize subsurface voids and to investigate the type and condition of the overburden above them, in order to select the best method(s) of subsidence prevention or mitigation. The findings of the geophysical investigation should be used to guide the boring exploration; suspected voids should be targeted.

As unconsolidated materials are not reliable bridging agents; the investigation of overburden is primarily aimed at determining the thickness and competency of rock above voids. Destructive drilling techniques may be used to locate voids and to determine the type and thickness of rock overburden, coring operations should be conducted to assess the RQD of rock overburden.

## **POSSIBLE MITIGATION OPTIONS**

Prevention of subsidence:

- Avoidance
- Excavation and backfill of subsurface voids and surface openings
- Pneumatic or hydraulic stowing of fill material into subsurface voids
- Dynamic compaction
- Explosive-induced collapse of subsurface voids
- Drilling and grouting of subsurface voids

Mitigation of subsidence effects:

- Bridging of lineaments over areas of potential subsidence
- Reinforced concrete pavement to span potentially minor subsidence
- Pre-cast concrete spans to bridge specific and isolated locations of subsidence

- Geogrid or geotextile emplacement over areas of potential subsidence

## RECOMMENDED AND CITED REFERENCES

Commonwealth of Kentucky, Kentucky Emergency Management. 2018. CH-EHMP S3-S6, 9: Mine Subsidence. In: *2018 Kentucky Hazard Mitigation Plan*. [electronic document]. Available from: <https://kyem.ky.gov/recovery/Pages/Recovery-Document-Library.aspx>

Didier, C., van der Merve, N., Betourney, M., Mainz, M., Kotyrba, A., Aydan, O., Josien, J. and Song, W. 2008. *Mine Closure and Post-Mining Management: International State-of-the-Art*. International Society for Rock Mechanics; Mine Closure Commission.

Dunrud, C.R., and Osterwald, F.W. 1980. *Effects of Coal Mine Subsidence in the Sheridan, Wyoming Area*. U.S. Geological Survey, Professional Paper 1164.

Lee, F.T. and Abel, J.F. 1983. *Subsidence from Underground Mining: Environmental Analysis and Planning Considerations*. U.S. Geological Survey, Circular 876.

National Mine Map Repository (NMMR). 2011. <https://mmr.osmre.gov/>

Rick Ruegsegger, L. 1998. *Manual for Abandoned Underground Mine Inventory and Risk Assessment*. U.S. Department of Transportation, Report No. FHWA-IF-099-007.

Waltham, A.C. 1989. *Ground Subsidence*. Blackie and Son Limited.

Whittaker, Barry N. and Reddish, David J. 1989. *Subsidence: Occurrence, Prediction, and Control*. New York: Elsevier, 541p.

### 3.8 SUBSIDENCE DUE TO FLUID-WITHDRAWAL

#### THREATS POSED TO ENGINEERED WORKS

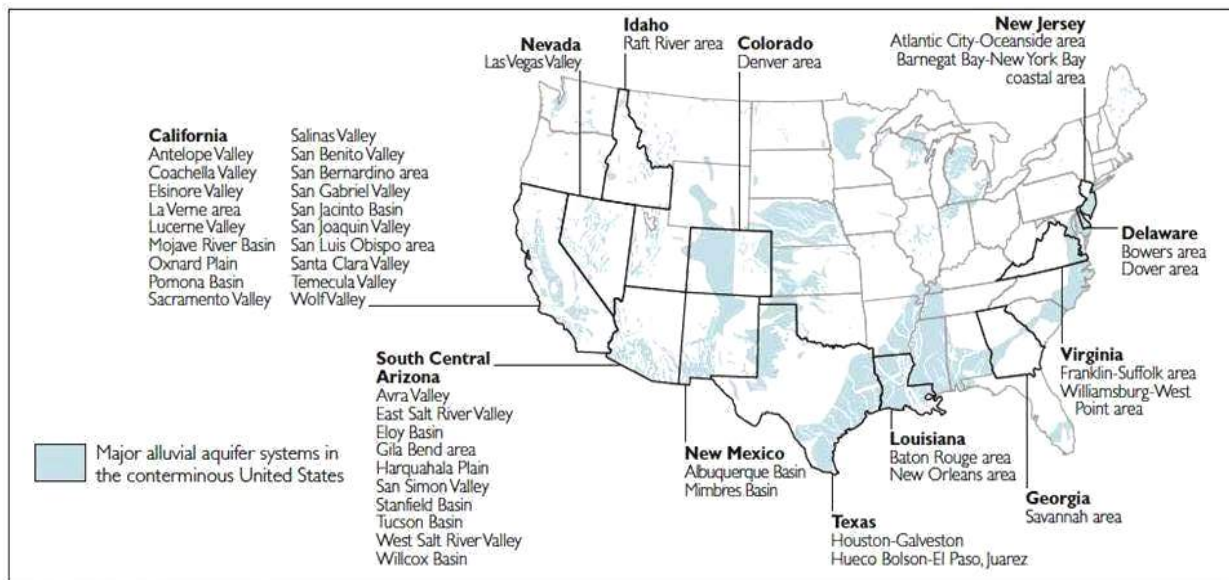
- Differential settlement, possibly accompanied by surface faulting and fissuring
- Regional subsidence

Differential settlement and surface faulting threaten structural integrity. Regional subsidence affects surface drainage and increases the risk of flooding and coastal inundation.

#### OCCURRENCE OF SUBSIDENCE DUE TO FLUID-WITHDRAWAL

Subsidence can be a result of groundwater or hydrocarbon-withdrawal. Hydrocarbon-withdrawal is usually less detrimental, primarily because hydrocarbons are extracted from greater depths where materials are solid rock with less void space. Subsidence due to hydrocarbon-withdrawal has occurred in the United States, notably in California and Texas. The prediction of such subsidence extraction is unreliable; perhaps the most effective means of mitigation is to install monitoring devices and plan for timely action should subsidence be detected.

Subsidence due to groundwater-withdrawal has occurred in many parts of the United States, as shown in Figure 3-20. With increasing demand for water, it is likely that more land will be affected. The mechanisms of such subsidence are well known and allow for subsidence prediction. Thus, in regions already affected by such subsidence and in areas known to be underlain by aquifers it is prudent to assess the potential for subsidence as part of a site investigation.



**Figure 3-20** Regions where land subsidence has been attributed to groundwater extraction, and areas underlain by major alluvial aquifers in the United States. From Galloway et al. (1999).



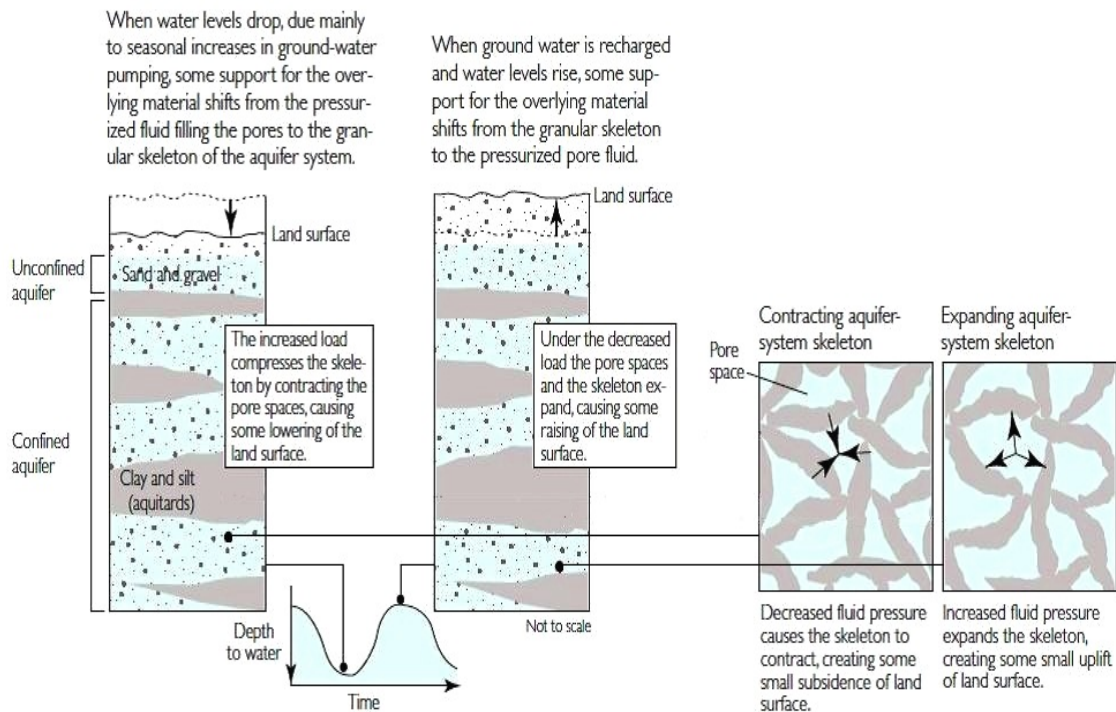
## MECHANISMS AND CONTROLS OF SUBSIDENCE

Subsidence due to fluid-withdrawal is a result of a decrease in pore pressure following head decline, which increases the effective stress on the soil or rock structure. Such subsidence is a regional phenomenon. Within regions of subsidence, differential subsidence can occur. Surface faulting and fissuring occurs due to subsurface volume reduction.

Surface subsidence occurs most often above aquifers in alluvial sediments containing both aquifers and aquitards, such as illustrated in Figures 3-21 and 3-22.

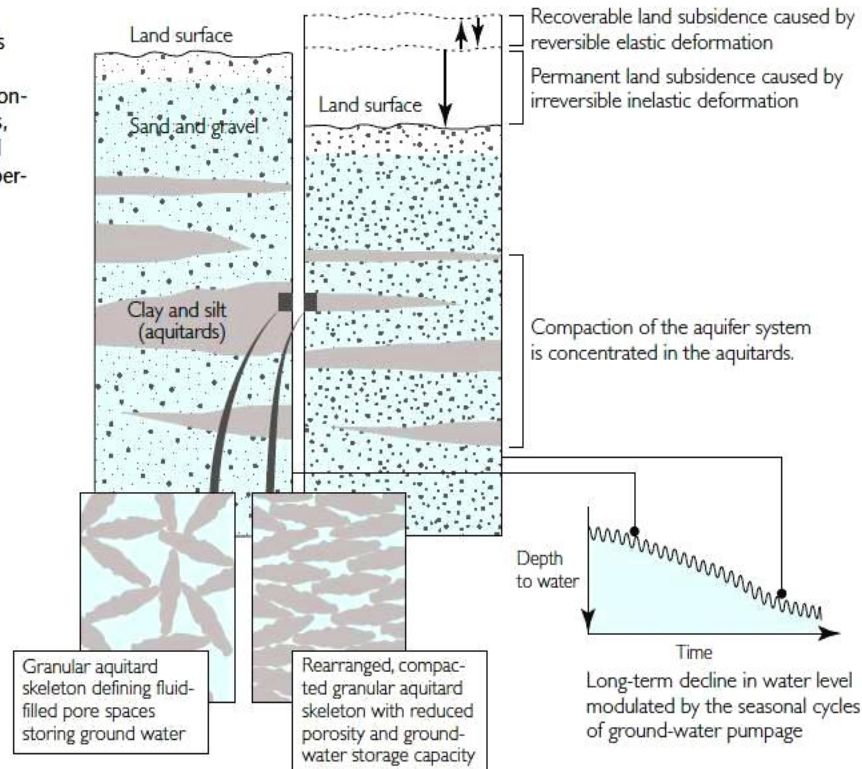
- Aquifers are coarse grained and sand-rich; they transmit water quickly.
- Aquitards are fine grained and clay or silt-rich; they transmit water slowly.

In aquifers an increase in effective stress is accommodated largely by grain rearrangement. The volume change is instantaneous, relatively minor and largely recoverable because once the pore fluid pressure rises the grains are pushed apart once again. Cyclic subsidence and rebound of this nature is illustrated in Figure 3-21, and occurs naturally with seasonal fluctuations in ground water levels.



**Figure 3-21** Cross section illustrating cyclic compaction and rebound of a sandy aquifer due to seasonal fluctuations in groundwater levels. From Galloway et al. (1999).

When long-term pumping lowers ground-water levels and raises stresses on the aquitards beyond the preconsolidation-stress thresholds, the aquitards compact and the land surface subsides permanently.



**Figure 3-22** Cross section illustrating irreversible compaction of clay-rich aquitards due to long-term groundwater extraction. From Galloway et al. (1999).

In aquitards any stress greater than the preconsolidation stress will result in permanent compaction. Aquitards, which have a higher percentage of clay minerals, generally have significantly higher porosity than aquifers (even though they have lower permeability than aquifers) and thus the potential for greater volume loss. The low permeability of aquitards causes hydrodynamic lag; compaction may continue for many years after groundwater levels have stabilized, as illustrated in Figure 3-22.

The amount of potential surface subsidence above alluvial aquifers is influenced by:

- Magnitude of groundwater table decline
- Cumulative thickness of clay aquitards
- Mineralogy of clay aquitards
- Preconsolidation history of clay aquitards

## SITE INVESTIGATION GOALS

- Determine if the site is underlain by a known alluvial aquifer or hydrocarbon reservoir (through review of existing information)
- Compile available pre-existing information on the properties and characteristics of aquifers or reservoirs at the site (through review of existing information)
- Determine if the site has a history of subsidence (through review of existing information)
- Investigate the stratigraphy of the aquifer (through boring and geophysical logging)

- e) Assess the sensitivity of the aquifer to compaction, the maximum potential subsidence of the site, and the possibility of differential subsidence across the site (through application of the depth-porosity model)

Step d can include sampling and laboratory testing of aquifer materials (physical, hydrologic and engineering properties and consolidation and rebound characteristics) if more advanced modeling of subsidence is required. Step e may be replaced by, or include, further modeling.

## **SITE INVESTIGATION ACTIONS**

### **Review of Existing Information**

The purpose of reviewing existing information is to:

- a) Determine if the site is underlain by a known aquifer or hydrocarbon reservoir
- b) Compile existing information of the underlying aquifer or reservoir to characterize the potential for subsidence
- c) Determine if the site has a history of subsidence

The U.S. Geological Survey has detailed maps of aquifers in the U.S. (USGS, 2011). The U.S. Energy Information Administration has detailed maps of oil and gas reservoirs in the U.S. (EIA, 2011).

Detailed information of specific aquifers is managed by State USGS Water Science Centers (WSC). If the site is underlain by an aquifer, of interest are:

- Type of aquifer (alluvial aquifers are most likely to experience regional subsidence)
- Geology and stratigraphy of aquifer
- Historic and forecast trends in water levels (these can be cross-referenced with recorded subsidence).

Since the modeling and prediction of subsidence due to hydrocarbon-withdrawal is unreliable it is perhaps unnecessary to obtain detailed information of underlying reservoirs. Useful information includes historic, current and forecast production rates (these can be cross-referenced with recorded subsidence).

As land subsidence is most often caused by groundwater-withdrawal, it is State Departments of Water Resources that are generally responsible for identifying, monitoring and keeping records of land subsidence. Of interest are magnitudes and rates of subsidence, and their relation to withdrawal or recharge rates of groundwater, or production rates from reservoirs.

By correlating past and present subsidence behavior with fluid-withdrawal, it is possible to gain a general understanding of the subsidence-susceptibility of a region. Since subsidence effects are usually lagged, it can be difficult and unreliable to predict future subsidence rates based upon correlation of specific withdrawal and subsidence events.

If the only threat of subsidence is posed by underlying hydrocarbon reservoirs, no subsurface investigations need be undertaken to specifically address this. This is because:

- Modeling and prediction of subsidence due to hydrocarbon-withdrawal is not reliable
- Hydrocarbon reservoirs exist at depths that make investigations for subsidence assessment unfeasible

## **Borings**

The purpose of borings in the investigation of aquifer subsidence is to identify aquifers and aquitards and to allow for geophysical logging. Sampling may also be required for more advanced subsidence modeling.

If destructive drilling techniques are used, aquifers and aquitards can be generally identified by the clay or sand content of drill cuttings. This method does not accurately delineate stratigraphic markers and thin stratigraphic layers, especially at depth.

If intact sampling techniques are used, aquifers and aquitards can be accurately identified after core recovery. If samples are not required, such techniques are a largely unnecessary expense.

The spacing of borings depends largely upon the nature of the planned works and the lateral variability of the strata. For linear structures borings may be spaced linearly at regular intervals; for large foundations, such as bridge piers, at least two borings should be made. Borings should be extended to the base of the aquifer.

## **Geophysical Logging**

Geophysical logging allows for accurate delineation of aquifers and aquitards and can measure the physical properties of aquifer materials in situ, should more advanced subsidence modeling be required.

Resistivity logging delineates individual aquifers and aquitards by measuring clay content, and can also locate the water table. Acoustic logging determines the density and porosity of materials. Logging can be carried out in real time while drilling or by wire-line after drilling.

## **Sampling**

Sampling is not required for depth-porosity modeling. Samples may be required for more advanced subsidence modeling. Laboratory analysis of physical and engineering properties requires undisturbed samples. Compositional and grain size distribution analyses do not require undisturbed samples. Samples need only be taken of strata within the aquifer.

The benefit of continuous sampling is that samples for testing can be taken from any part of the boring; in this case they should be chosen to represent the various stratigraphic layers encountered. If destructive drilling techniques are used in conjunction with a Shelby- or split-

tube, samples must be taken at regular intervals and the depth of each sample then correlated with the geophysical borehole log to identify its stratigraphic unit.

### Depth-Porosity Model

The depth-porosity model for surface subsidence, shown in the equation below, gives an estimate of potential long-term subsidence at any given site by estimating the total compaction of aquitard layers. The model requires:

- Average depth of the aquifer
- Cumulative thickness of aquitards in the aquifer

The model estimates, for each boring location:

- Sensitivity of the aquifer (the ultimate compaction per unit depth of drawdown)
- Total compaction for a given drawdown

$$\frac{\Delta b'}{\Delta h} \approx S_{skv} \times b'$$

Where:

$\Delta b'$  = Ultimate compaction

$\Delta h$  = Long term drawdown

$S_{skv}$  = Specific storage for non-recoverable compaction, from Figure 3-23

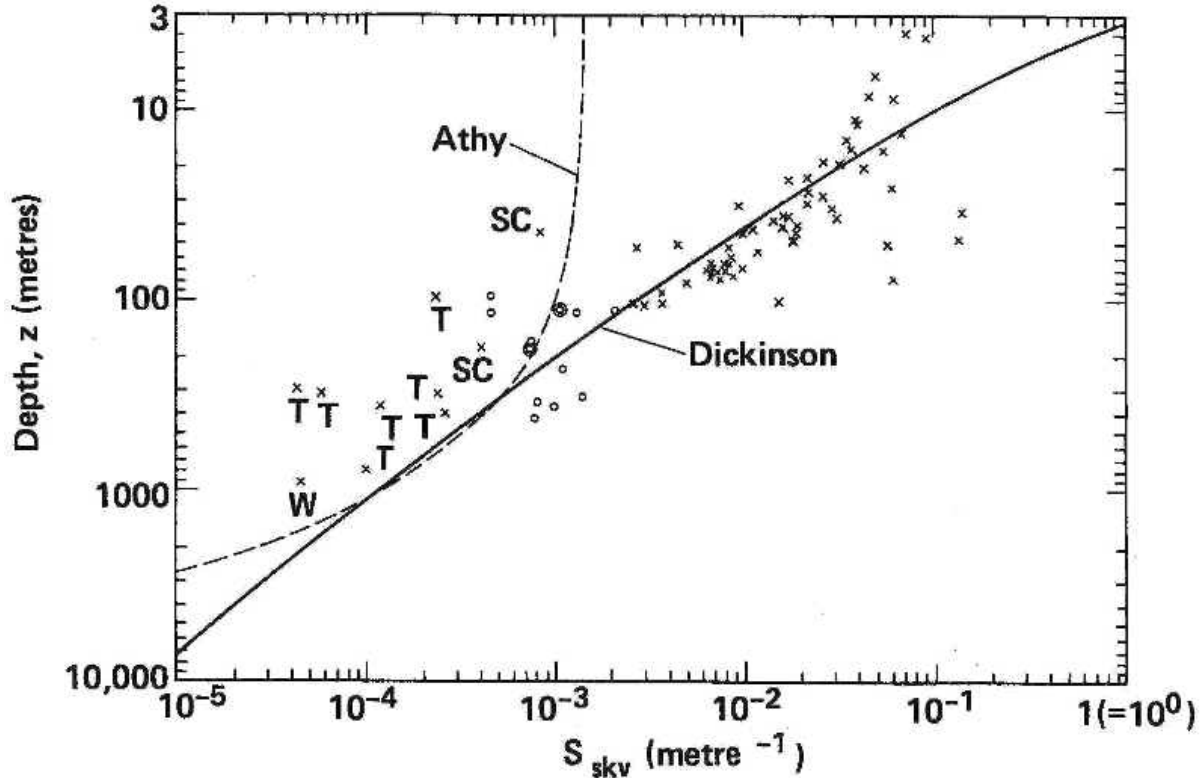
$b'$  = Cumulative thickness of aquitards in aquifer

The specific storage for non-recoverable compaction ( $S_{skv}$ ) is a coefficient that accounts for the decrease of void space with depth. Figure 3-23 shows the relation of  $S_{skv}$  and depth for two data sets. For depths shallower than 2000 meters the Dickinson line is generally considered to provide a better estimate of  $S_{skv}$ .

It may be useful to characterize the potential subsidence for a large area by averaging the potential compaction estimates from the boreholes within it. Areas with the potential for differential subsidence may be indicated by adjacent boreholes with variable estimates of potential compaction.

### POSSIBLE MITIGATION OPTIONS

- Avoidance of development over alluvial aquifers and hydrocarbon reservoirs
- Control of aquifer extraction and recharge rates to maintain groundwater levels
- Control of hydrocarbon extraction and depressurizing of reservoirs
- Installation of monitoring systems to facilitate the timely implementation of retroactive solutions



**Figure 3-23.** Specific storage for non-recoverable compaction ( $S_{skv}$ ) as a function of depth. The depth used should be the average depth of the aquifer. For depths of 2000 m or less the Dickinson line is considered to give best results. From Helm (1984).

### RECOMMENDED AND CITED REFERENCES

Galloway, D. Jones, D. Ingebritsen, S. 1999. Land Subsidence in the United States. U.S. Geological Survey, Circular 1182.

Gambolati, G., Teatini, P., and Ferronato, M. 2005. 158: Anthropogenic Land Subsidence. In: *Encyclopedia of Hydrological Sciences*, M.G. Anderson (ed.), John Wiley and Sons.

Helm, D.C. 1984. Field-based computational techniques for predicting subsidence due to fluid-withdrawal. Geological Society of America, Reviews in Engineering Geology, Vol. 6, pp. 1-22.

Holzer, T.L. and Galloway, D.L. 2005. Impacts of land subsidence caused by withdrawal of underground fluids in the United States. In: *Humans as Geologic Agents*, J. Ehlen, W.C. Haneberg, and R.A. Larson, (eds.). Geological Society of America.

Poland, J.F. 1984. Guidebook to Studies of Land Subsidence due to Groundwater-withdrawal. Unesco Studies and Reports in Hydrology.

Robertson, John O. and Chilingar, George V. 2017. Subsidence as a Result of Gas/Oil/Water Production. In: *Environmental Aspects of Oil and Gas Production*. Hoboken, NJ: John Wiley and Sons. 394 p.

Sneed, M., and Galloway, D.L. 2000. Aquifer - System Compaction and Land Subsidence: Measurements, Analyses, and Simulations - the Holly Site, Edwards Air Force Base, Antelope Valley, California. U.S. Geological Survey, Water Resources Investigations Report No. 00-4015.

United States Geological Survey (USGS). 2011. Groundwater Information Pages, Resources and Introductory Information. <http://water.usgs.gov/ogw/basics.html#aquifers>

United States Energy Information Administration (EIA). 2011. Maps: Exploration, Resources, Reserves and Production. <https://www.eia.gov/maps/>

## 3.9 COLLAPSIBLE SOILS

### THREATS POSED TO ENGINEERED WORKS

- Rapid surface settlement, due to hydrocompaction
- Fissuring and surface collapse, due to soil dispersion
- High erodibility

### FIELD INDICATORS OF COLLAPSIBLE SOILS

- Porous soils with a high void ratio
- Unusually high angles of repose on cuts (loose soil grains are cemented by clay)
- Collapse features (depressions, radial cracks)
- Piping features (fissures, gullies, pipes, voids etc.)

### OCCURRENCE OF COLLAPSIBLE SOILS

Collapsible soils are found in arid and semi-arid regions, where silt-rich sediments accumulate without ever being fully wetted. Alluvial and colluvial fans, debris flow sediments and loess deposits (wind-blown) are commonly host to collapsible soils. Alluvial and colluvial fans typically form at slope bases, loess deposits may form on open plains and leeward hill slopes.

### MECHANISMS OF SOILS COLLAPSE

Collapsible soils have high silt content, with some fraction of both clay and sand. They are highly porous. At points of contact the silt-size grains are bonded by clay, which imparts some shear strength to the soil when dry. When wetted, such soils are highly erodible and may experience hydrocompaction. When subjected to through-flow of water such soils may experience dispersion.

#### Hydrocompaction

Upon wetting, the clay binder becomes plastic and the soil structure is likely to collapse under its own weight or a surcharge load. Hydrocompaction usually causes rapid surface settlement and the formation of depressions. The potential severity of hydrocompaction of a soil is termed the 'collapse potential'.

#### Dispersion

The surfaces of clay particles are electrically charged, making them susceptible to dispersion in water (deflocculation). Clay particles can be dispersed and transported by very low-velocity flows, gradually forming and enlarging surface fissures and underground pipes that may cause surface collapse. Collapsible soil deposits are highly susceptible to clay dispersion due to their high porosity which facilitates through-flow of water.



## **Erosion**

The weakening of the soil structure when wetted, combined with the tendency of clay particles to disperse in water, makes collapsible soils highly erodible by flowing water, both on the surface and underground along fissures and pipes.

## **SITE INVESTIGATION GOALS**

- a) Establish the thickness and extent of collapsible soil units (through boring and field testing)
- b) Assess the collapse potential of soils at the site (through field testing and/or sampling and laboratory analysis).
- c) Assess the dispersivity of soils at the site (through sampling and laboratory analysis).

## **SITE INVESTIGATION ACTIONS**

### **Establishing the Thickness and Extent of Collapsible Soils**

#### ***Borings***

Borings in collapsible soils aim to establish the depth and extent of the collapsible soil layer. Borings should be spaced according to the nature of the planned works, and advanced to at least the base of the collapsible soil layer.

If collapsible soils overlie bedrock or saturated soils, the contact between the two can be easily identified. When collapsible soils overlie non-collapsible soils, the contact between the two may be indicated by a decrease in the penetration speed, due to a decrease in void ratio. Drill cuttings are unlikely to retain the structure of the undisturbed soil, especially when drilling with water.

#### ***Field Testing***

Possibly the quickest way to ascertain if a soil is collapsible is to perform the sausage test (described below) on an undisturbed sample. This test should be performed on samples from regular depth intervals across the site to identify the base of the collapsible soil layer.

Sausage test:

This is a relatively crude test, good only for judging if collapse potential is likely to exist. A block of undisturbed soil is broken into two pieces of roughly equal volume. One is placed in a plastic bag, wetted and molded by hand to form a damp ball. The volume of the molded piece is then compared to that of the undisturbed piece. If the molded piece is smaller, the soil has collapse potential (Jennings and Knight, 1975). It should be noted that, while soil collapse of only a few percent may be sufficient to cause damage to structures, the sausage test may not be sensitive enough to recognize such a low collapse potential.

## Assessing the Collapse Potential of Soils

### *Field Testing*

Field testing of hydrocompaction in collapsible soils provides realistic information of collapse processes at the site. Of the methods below, the plate-load test will generally provide the most accurate information.

Sausage test: Described above

Test ponds:

Vertical markers are emplaced in a shallow excavation, which is filled with water. The resulting hydrocompaction is monitored by measuring settlement of the markers.

Plate-load tests:

Topsoil is removed and a pad emplaced with a known load, to produce a specific bearing pressure. The ground around the load is surveyed. Water is ponded on the soil around the load. The ground is surveyed at regular intervals to monitor the progressive hydrocompaction (Luehring, 1988. CDOT and others, 2000)

### *Sampling*

Undisturbed samples are necessary for the consolidometer test. Retrieving quality undisturbed samples in collapsible soils can be difficult. While better quality samples can be retrieved using a large-diameter pitcher-type sampler with a lined tube, perhaps the best samples are obtained by cutting blocks from trenches or pits (ASTM 7015) (Higgins and Modeer, 1996).

Disturbed samples are sufficient for the determination of general susceptibility to hydrocompaction, however, their original in-situ volume must be known.

### *Laboratory Testing*

Collapse potential (CP):

- Consolidometer Test (AASHTO T 216; ASTM D2435)(modified)
  - The undisturbed sample is subjected to a specific load, then flooded with water and allowed to saturate. The magnitude of resulting hydrocompaction is measured.

General susceptibility to hydrocompaction:

- Amount of Material Finer than No. 200 Sieve (AASHTO T 88; ASTM D1140)
- Determination of Liquid and Plastic Limits (AASHTO T 90; ASTM D4318)
- Determination of Moisture Content (AASHTO T 265; ASTM D4959)

### ***Interpretation of Laboratory Results***

From the consolidometer test:

$$CP(\%) = \frac{\text{Change in height of sample}}{\text{Original height of sample}} \times 100$$

The CP value obtained can be used to classify the severity of the hydrocompaction hazard according to existing classification schemes, two examples of which are shown below in Tables 3-2 and 3-3. The magnitude of possible surface collapse can also be approximated by multiplying the CP value by the thickness of the collapsible layer. Experimental CP values are specific to the experimental load applied, as are the hazard classifications and collapse magnitudes derived from them.

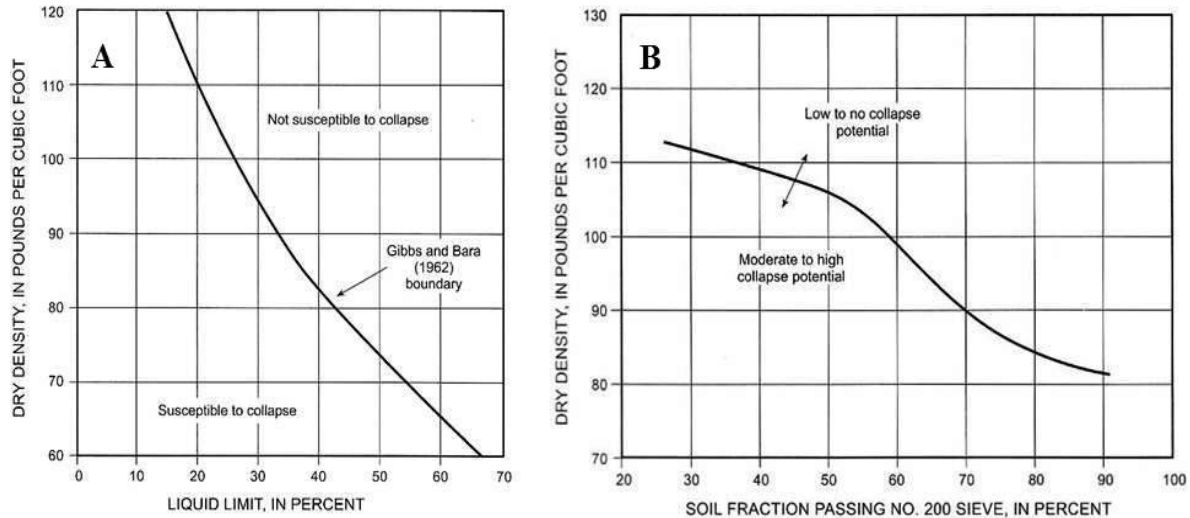
Analysis of the physical properties of a collapsible soil can indicate its general susceptibility to hydrocompaction, based upon empirical relationships. Some examples are shown below in Figure 3-24.

**Table 3-2** Severity Criteria for soil collapse with test load of 4,200 psf. From Jennings and Knight (1975).

<b>CP (%)</b>	<b>Severity of Problem</b>
0 – 1	No problem
1 – 5	Moderate problem
5 – 10	Trouble
10 – 20	Severe trouble
> 20	Very severe trouble

**Table 3-3** Hazard Criteria for soil collapse with test load of 1,000 psf. From Mock and Pawlak, (1983).

<b>CP (%)</b>	<b>Hazard</b>
0 – 1	No problem
1 – 3	Low
3 – 5	Moderate
> 5	High



**Figure 3-24** Examples of empirical relationships between soil properties and susceptibility to collapse. Chart A: Empirical relationship between dry density and liquid limit for collapsible soils, showing the Gibbs and Bara (1962) susceptibility boundary. Chart B: Empirical relationship between dry density and percent fines for collapsible soils, showing the Mock and Pawlack (1983) susceptibility boundary.

### Assessing the Dispersivity of Soils

#### Sampling

Undisturbed samples are necessary for the crumb test and pinhole test. Disturbed samples are sufficient for the double hydrometer test. Each test stands alone as an indicator of dispersivity.

Retrieving quality undisturbed samples in collapsible soils can be difficult. While better quality samples can be retrieved using a large-diameter pitcher-type sampler with a lined tube, perhaps the best samples are obtained by cutting blocks from trenches or pits (ASTM 7015) (Higgins and Modeer, 1996).

#### Laboratory Testing

- Crumb Test (ASTM D6572)
- Pinhole Test (ASTM D4647)
- Double Hydrometer Test (ASTM D4221)

#### Interpretation of Laboratory results

The crumb test is a qualitative assessment, in which a small soil sample at natural water content is placed in a beaker of distilled water and observed for 5 to 10 minutes. An interpretation guide is presented in Table 3-4.

The pinhole test is a qualitative assessment, in which a small hole is punched in a sleeved cylindrical sample. Distilled water is passed through the sample at a constant rate, as the effluent from the hole is observed. If the effluent flow is clear and the hole does not enlarge, the soil is considered non-dispersive. If the effluent flow is cloudy, or if the hole enlarges, the soil is considered dispersive (NRCS, 1991).

**Table 3-4** Dispersivity classifications that may be applied to the crumb test. From Sherard et al. (1976).

Dispersivity	Indicative Behavior
Grade 1	No reaction. Crumb may slake and develop as a flattened pile on the bottom of the beaker, but there is no sign of cloudy water, no colloids in suspension.
Grade 2	Slight reaction. Just a hint of cloudy water near the surface of the crumb.
Grade 3	Moderate reaction. Easily recognizable cloud of colloids in suspension, usually spreading out in thin streaks from the crumb on the bottom of the beaker.
Grade 4	Strong reaction. Colloidal cloud covers nearly the whole bottom of the beaker, usually in a very thin skin. In extremely dispersive crumbs, initial streamers of colloids can be seen, at times arcing from the crumb, and the entire volume of water can become cloudy.

The double hydrometer test is a quantitative assessment, in which hydrometer analyses are performed on two identical samples of the same soil. One sample is allowed to disperse naturally; the other sample is mixed with a dispersing agent and subjected to mechanical agitation (as in a standard hydrometer test). The natural dispersion is quantified against the chemically and mechanically aided dispersion. Table 3-5 shows how the dispersion percent can be interpreted as a measure of dispersive behavior.

$$Dispersion (\%) = \frac{\text{Percent clay size in suspension after natural dispersion}}{\text{Percent clay size in suspension after chemical and mechanical dispersion}} \times 100$$

**Table 3-5** Dispersivity classifications that may be applied to the double hydrometer test. From the National Resources Conservation Service (NRCS) (1991).

Dispersion (%)	Interpretation
> 60	The soil is probably dispersive
< 30	The soil is probably not dispersive
30 – 60	More tests are needed

## POSSIBLE MITIGATION OPTIONS

- Avoidance of collapsible soils
- Avoidance of wetting of collapsible soils, during the entire lifespan of the structure
- Excavation of collapsible soils
- Pre-wetting of collapsible spoils, to induce hydrocompaction prior to construction
- Dynamic or vibratory compaction, possibly combined with pre-wetting
- Grouting with chemical stabilizing agents
- Appropriate foundation designs (deep foundations, spread footings, grid foundations etc.)

## RECOMMENDED AND CITED REFERENCES

Colorado Department of Transportation (CDOT), Colorado Geological Survey (CGS), Parsons Transportation Group, MK Centennial, and Yeh and Associates. 2000. Geotechnical Data Report, State Highway 82, Snowmass Canyon. CDOT Project, CD-ROM.

Culshaw, M., and Jefferson, I. 2018. Collapsible Soils. In: *Encyclopedia of Engineering Geology, 2018 ed., Bobrowsky, P.T., Marker B. (eds), Springer, Cham.*

Gibbs, H.J., and Bara, J.P. 1962. Predicting Surface Subsidence from Basic Soil Tests. U.S. Department of the Interior Bureau of Reclamation, Soils Engineering Report No. EM658.

Higgins, J.D. and Modeer, V.A., Jr. 1996. Loess. In *Landslides: Investigation and Mitigation* (Chapter 23). Transportation Research Board, Special Report 247. National Research Council.

Houston, S.L. Houston, W.N., Zapata, C.E., and Lawrence, C. 2001. Geotechnical engineering practice for collapsible soils, *Geotechnical and Geological Engineering*, Vol. 19, pp 333-355.

Jefferson, Ian and Rogers, Chris D.F. 2012. "Chapter 32: Collapsible soils". In: *ICE Manual of Geotechnical Engineering, Volume 1 - Geotechnical Engineering Principles, Problematic Soils and Site Investigation*, John Burland, Tim Chapman, Hilary Skinner, and Michael Brown eds. London: ICE Publishing.

Jennings, J.E., and Knight, K. 1975. A guide to Construction On or With Materials Exhibiting Additional Settlement Due to Collapse of Grain Structure. Proceedings of the 6<sup>th</sup> Regional Conference for Africa on Soil Mechanics and Foundation Engineering, Durban, South Africa, v. 1, pp. 99-105.

Karakouzian, M., and Roullier, P.L. 1993. Probabilistic Model for Collapse Potential Prediction of Las Vegas Soils. *Bulletin of the Association of Engineering Geologists*, v. 30, No. 3, pp. 331-343.

Leuhring, R.W. 1988. Evaluations of Collapse Susceptibility in Alluvial Fan Deposits, Towaoc Canal, Reach 2, Towaoc, Colorado. U.S. Department of the Interior, Bureau of Reclamation, Division of research and Laboratory Services, Geotechnical Services Branch.

- Mock, R.G., and Pawlack, S.L. 1983. Alluvial Fan Hazards at Glenwood Springs. *In* Geological Environment and Soil Properties, ASCE Conference Proceedings, Houston, Texas, October 17-21, American Society of Civil Engineers, pp. 221-233.
- National Resources Conservation Service (NRCS). 1991. Dispersive Clays: U.S. Department of agriculture, NRCS Engineering Division, Soil Mechanics Note No. 13.
- Roullier, P.L., and Stilley, A.N. 1993. Methods of Identifying Hydrocollapse Potential of Soils. *In* Proceedings of the 29<sup>th</sup> Annual Symposium on Engineering geology and Soils Engineering, March 22-24, Reno, Nevada, pp. 484-503.
- Sabatini, P.J., Bachus, R.C., Mayne, P.W., Schneider, J.A., and Zettler, T.E. 2002. Loess. *In* Geotechnical Engineering Circular No. 5: Evaluation of Soil and Rock Properties (Section 7.2). U.S. Department of Transportation, Report No. FHWA-IF-02-034.
- Sherard, J.L., Dunnigan, L.P., and Decker, R.S. 1976. Identification and Nature of Dispersive Soils. *Journal of the Geotechnical Engineering Division*, Vol. 102, No. GT4, pp. 298-312.
- United States Department of Agriculture (USDA) 1991. Dispersive Clays. U.S. Department of Agriculture, NRCS Engineering Division, Soil Mechanics Note No. 13.
- White, J.L., and Greenman, C. 2008. Collapsible Soils in Colorado. Colorado Geological Survey, Engineering Geology 14.

### **3.10 ORGANIC SOILS AND PEAT**

#### **THREATS POSED TO ENGINEERED WORKS**

- Significant primary and secondary consolidation of deposits
- Differential settlement over short distances
- Low shear strength
- Anisotropic shear strength and permeability
- Microbial-induced corrosion of metals

#### **FIELD INDICATORS OF ORGANIC SOILS AND PEAT**

- Soils have a green, grey or black color
- Soils may have a foul smell due to decomposition of organic matter
- Soils contain plant matter such as fibers or wood fragments

#### **OCCURRENCE OF ORGANIC SOILS AND PEAT**

Soils high in organic matter tend to form under wet or cold conditions, irrespective of latitude or elevation, where the activity of decomposing agents is impeded by low temperature or excess moisture.

#### **ENGINEERING CHARACTERISTICS OF ORGANIC SOILS AND PEAT**

Organic materials in soils act to increase the void ratio and water content, and decrease the bulk density. This is because organic matter is largely comprised of inter-cellular water. Organic matter decays to produce methane, ammonia, hydrogen sulfide, and more void space.

Organic soils experience significant primary consolidation due to their high void ratio and water content; they also undergo significant and prolonged secondary deformation due to the slow loss of inter-cellular water and the decay of organic matter. Organic soils are typically low-density, saturated and not significantly over-consolidated; thus they typically have low shear strength.

Engineering properties of organic soils can be highly variable laterally and vertically, due to variability in the concentration and type of organic content, and the degree of decay. Plant fibers in soil tend to be oriented horizontally; thus in highly organic soils permeability is usually highest, and shear strength lowest, in the horizontal plane.

Peat is soil composed overwhelmingly of organic material that has been preserved under conditions of incomplete aeration and high water content. The void ratio of peat can be as high as 25, water content as high as several hundred percent or more, and specific gravity as low as 1.1. With decay, peat transitions from being highly fibrous to more granular and amorphous. A decrease of void ratio in peat may cause a significant decrease in permeability. This affects settlement behavior.



## SITE INVESTIGATION GOALS

- a) Establish the depth and extent of organic soils (through boring and/or field testing)
- b) Determine the organic, moisture, and fiber contents of soils and classify them (through sampling and laboratory testing)
- c) Investigate the shear strength and consolidation characteristics of soils (through sampling and laboratory testing)

## SITE INVESTIGATION ACTIONS

### Borings

Borings aim to determine the depth and lateral extent of organic soils. Organic soils can be recognized in cuttings by the presence of decaying vegetative matter, which often has a distinctive odor. Organic soils are typically greenish to dark grey to black in color, and may contain fibers, woody fragments and other plant structures.

### Field Testing

Organic soils can also be recognized in CPT borings by low tip resistance and high wall friction.

### Sampling

Disturbed samples are sufficient for the measurement of organic, ash, moisture and fiber content. Undisturbed samples are necessary for the testing of shear strength and consolidation behavior. In very fibrous soils it may be difficult to obtain undisturbed samples with a tube-type sampler; in this case block-sampling techniques can be employed (ASTM 7015).

Sampling should be focused at foundation locations. Since the engineering properties of organic soils can be highly variable over short distances, samples should be taken at small intervals (laterally and vertically) in these locations.

### Laboratory Testing

For classification of organic soils:

- Moisture, Ash and Organic Matter of Soils (AASHTO T 267; ASTM D2974)
- Fiber Content of Peat and Organic Soils (ASTM D1997)

For testing of shear strength of organic soils (for more fibrous soils with higher permeability, drained shear strength may be of greater importance):

- Triaxial Compression Test (UU) (AASHTO T 296; ASTM D2850)  
(CU) (AASHTO T 297; ASTM D4767)  
(CD) (ASTM WK3821)
- Direct Shear Test (CD) (AASHTO T 236; ASTM D3080)

To model consolidation behavior:

- One-Dimensional Consolidation Properties of Soils (AASHTO T 216; ASTM D2435)

### Interpretation of Laboratory Results

In the test for ash and organic matter of soil the dry sample is heated at very high temperatures, which volatilizes all of the organic content. The remainder of the sample is ash, which is calculated as a mass percentage of the dry sample. The organic percentage is thus 100 minus the ash percentage. Table 3-6 can be used to classify the soil according to its ash, moisture and fiber content.

**Table 3-6** Properties and classification of organic soils and peat. Adapted from Landva et al (1983).

Soil Classification	Ash Content (%)	Organic Content (%)	Moisture Content (%)	Specific Gravity	Fiber Content (%)
Peat (Pt)	< 20	> 80	> 500	< 1.7	> 50
Peaty Organic Soil (PtO)	20 – 40	60 – 80	150 – 800	1.6 – 1.9	< 50
Organic Soil (O)	40 - 95	5 – 60	100 – 500	> 1.7	Insignificant
Silts and Clays with Organic Content (MO, CO, respectively)	95 – 99	1 - 5	< 100	> 2.4	None

Results of the consolidation tests of the soils can be interpreted graphically to evaluate the coefficients of consolidation for specific loads, the stress history of the soil (maximum previous load), and the coefficients of recompression and compression.

### POSSIBLE MITIGATION OPTIONS

- Avoidance
- Excavation of organic soils
- Pre-consolidation of organic soils prior to development. This will mitigate primary consolidation, but may not mitigate secondary consolidation

## RECOMMENDED AND CITED REFERENCES

De Arriba-Rodriguez, L., Villanueva-Balsera, J., Ortega-Fernandez, F., and Rodriguez-Perez, F. 2018. Methods to Evaluate Corrosion in Buried Steel Structures: A Review. *Metals*, Vol. 8., Iss. 5., 334.

Farrell, Eric R. 2012. "Chapter 35: Organics/peat soils". In: *ICE Manual of Geotechnical Engineering, Volume 1 - Geotechnical Engineering Principles, Problematic Soils and Site Investigation*, John Burland, Tim Chapman, Hilary Skinner, and Michael Brown eds. London: ICE Publishing.

Galloway, D., Jones, D.R., and Ingebritsen, S.E. (eds) 1999. Part II: Drainage of Organic Soils. In: *Land Subsidence in the United States*, US Department of the Interior, US Geological Survey, Circular 1182, pp. 79-106.

Huat, B.B.K., Prasad, A., Asadi, A., and Kazemian, S. 2014. *Geotechnics of Organic Soils and Peat*. CRC Press, 250 p.

Kazemian, S., Huat, B.B.K., Prasad, A., and Barghchi, M. 2011. A state of art review of peat: Geotechnical engineering perspective. *International Journal of the Physical Sciences*, Vol 6, Iss. 8, pp. 1974-1981.

Landva, A.O., Korpijaakko, E.O., and Pheeney, P.E. 1983. Geotechnical Classification of Peats and Organic Soils. In *Testing of Peats and Organic Soils*, ASTM Special Technical Publication No.820.

Sabatini, P.J., Bachus, R.C., Mayne, P.W., Schneider, J.A., and Zettler, T.E. 2002. Organic Soils and Peat. In *Geotechnical Engineering Circular No. 5: Evaluation of Soil and Rock Properties (Section 7.4)*. U.S. Department of Transportation, Report No. FHWA-IF-02-034

Vargel, C. 2004. Chapter G.1 – Corrosion in Soil. In: Vargel, C. (ed) *Corrosion of Aluminum*, Amsterdam: Elsevier, pp. 551-556.

### 3.11 SENSITIVE CLAYS

#### THREATS POSED TO ENGINEERED WORKS

- Sensitive clays have low shear strength and low bearing capacity
- Highly sensitive soils may collapse or liquefy when subjected to shock, vibration, or an increase in water content

#### FIELD INDICATORS OF SENSITIVE CLAYS

Clays are sensitive as a result of their depositional history. This sensitivity is not manifested in visual indicators. The sensitivity of clays can only be confirmed by field and laboratory tests.

#### MECHANISM OF CLAY SENSITIVITY

The sensitivity of a soil ( $S_t$ ) is the ratio of its peak strength in the undisturbed state ( $S_u$ ) to its ultimate strength when remolded ( $S_r$ ), tested at the same water content and under the same conditions:

$$Sensitivity = \frac{Undisturbed\ Peak\ Strength}{Remolded\ Ultimate\ Strength}$$

Sensitive soils in the undisturbed state have a metastable structure. The strength of this structure is largely due to the bonds at the points of contact of the soil particles. The soil loses much of its strength if the inter-particle bonds are destroyed by remolding.

Soils with considerable sensitivity are usually clays. The inter-molecular attractive forces of clay particles allow for the formation of relatively high-strength soil frameworks under natural depositional conditions over geological time. When this structure is remolded a large part of its strength may be lost. Thixotropic hardening may occur in some clays after remolding, given time to 'rest' under constant external conditions. This process restores some of the clay strength, through partial recovery of the electrostatic bonds between the clay particles, but to only a fraction of the original undisturbed strength.

Clays deposited in salt water become highly sensitive when they are uplifted and the saltwater contained is leached out and replaced by fresh water. This leaching process greatly reduces the electrostatic forces within the soil structure, making it highly unstable.

Quick clays are extremely sensitive. They are widely accepted to originate from glacial deposits in marine environments, and are commonly found in the glaciated terrains of Canada and Alaska. Quick clays contain a large component of silt and rock flour, and often have natural moisture content above their liquid limit. Quick clays readily liquefy when disturbed.

#### SITE INVESTIGATION GOALS

- a) Establish the depth and extent of clay units (through boring)

- b) Determine the sensitivity of clay units, through field testing and/or sampling and laboratory analysis

## **SITE INVESTIGATION ACTIONS**

### **Borings**

The purpose of borings in sensitive clays is to determine the depth and lateral extent of clay units, and to recover samples for laboratory analysis. Boring depths and spacing depend upon the nature of the planned works. It may be desirable to perform vane shear tests at the bottom of boreholes, at specific intervals.

### **Field Testing**

The purpose of the vane shear test in sensitive clays is to assess their sensitivity, by measuring both the peak shear strength and the ultimate shear strength. This test can be performed on soils at the surface, exposed in test pits or trenches, and at the bottom of boreholes.

- Field Vane Shear Test in Cohesive Soil (AASHTO T 223; ASTM D2573)

### **Sampling**

Samples should be taken of all soil units encountered in borings, with special attention to clay-rich soils given their potential for high sensitivity. Undisturbed samples are required for laboratory determination of sensitivity.

A thin-walled Shelby tube or piston sampler may be appropriate for soils of low to moderate sensitivity, for more sensitive clays and quick clays it is necessary to use wider sampling tubes lined with foil to reduce sample disturbance. Near-surface soils may be sampled by the cutting of blocks from pits or trenches, when performed correctly this provides high-quality undisturbed samples (ASTM D7015).

### **Laboratory Testing**

From each soil unit identified in the field; undrained triaxial compression tests should be performed on undisturbed and remolded specimens, at the same water content and confining pressure. The confining pressure should be matched to that of the soil in the field.

- Triaxial Compression Test (UU) (AASHTO T 296; ASTM D2850)  
(CU) (AASHTO T 297; ASTM D4767)

### **Interpretation of Field and Laboratory Results**

Given the peak strength of the undisturbed soil and the ultimate strength of the remolded soil; the sensitivity can be classified according to Table 3-7, using the calculated sensitivity ( $S_t$ ) from the following equation:

$$S_t = \frac{S_u}{S_r}$$

Where

$S_t$  = clay sensitivity,

$S_u$  = peak strength of undisturbed clay,

$S_r$  = ultimate strength of remolded soil

**Table 3-7** Classification of soil by sensitivity. From Bjerrum (1954)

Sensitivity ( $S_t$ )	Classification
< 2	Insensitive
2 – 4	Moderately Sensitive
4 – 8	Sensitive
8 – 16	Very Sensitive
16 – 32	Slightly Quick
32 - 64	Medium Quick
> 64	Quick

## POSSIBLE MITIGATION OPTIONS

- Avoidance
- Excavation of sensitive soils
- Chemical treatment of remolded soils to increase their strength

## RECOMMENDED AND CITED REFERENCES

Bjerrum, L. 1954. Geotechnical Properties of Norwegian Marine Clays. *Geotechnique*, Vol. 4, No. 2, pp. 49-69.

Lefebvre, G. 1996. Soft Sensitive Clays. *In* Landslides: Investigation and Mitigation (Chapter 24). Transportation Research Board, Special Report 247. National Research Council.

Sabatini, P.J., Bachus, R.C., Mayne, P.W., Schneider, J.A., and Zettler, T.E. 2002. Sensitive Clays. *In* Geotechnical Engineering Circular No. 5: Evaluation of Soil and Rock Properties (Section 7.8). U.S. Department of Transportation, Report No. FHWA-IF-02-034

Sandven, R., Gylland, A., Montafia, A., Kasin, K., Pfaffhuber, A.A., and Long, M. 2016. In situ detection of sensitive clays – Part I: Selected test methods. *Proceedings of the 17<sup>th</sup> Nordic Geotechnical meeting: Challenges in the Nordic Geotechnic*, 25-28 May 2016.

Sandven, R., Gylland, A., Montafia, A., Kasin, K., Pfaffhuber, A.A., and Long, M. 2016. In situ detection of sensitive clays – Part II: Results. *Proceedings of the 17<sup>th</sup> Nordic Geotechnical meeting: Challenges in the Nordic Geotechnic*, 25-28 May 2016.

Torrance, J.K. 2012. 8. Landslides in Quick Clay. In: Clague, J.J. and Douglas, S. (eds) *Landslides – Types, Mechanisms and Modeling*, Cambridge University Press, pp. 83-94.

## 3.12 PERMAFROST

### THREATS POSED TO ENGINEERED WORKS

- Seasonal frost-heaving and thaw-weakening of soils in the active layer (see Section 3.4)
- Thaw-weakening and thaw-settlement of soils in the permafrost layer

### FIELD INDICATORS OF PERMAFROST

- Polygonal (patterned) ground
- Stone nets
- Solifluction sheets
- Ice wedges
- Pingos

### OCCURANCE OF PERMAFROST

Permafrost is permanently frozen ground, defined as being continually below freezing for more than two years. Permafrost in the United States is largely limited to Alaska, where it affects approximately 85 percent of the state; its distribution is shown in Figure 3-25. Permafrost also exists in high alpine regions of the contiguous U.S., although its occurrence is not well documented. It is estimated that 100,000 km<sup>2</sup> of permafrost occurs in high alpine regions of the western U.S., from Washington to Arizona (Péwé, 1983).

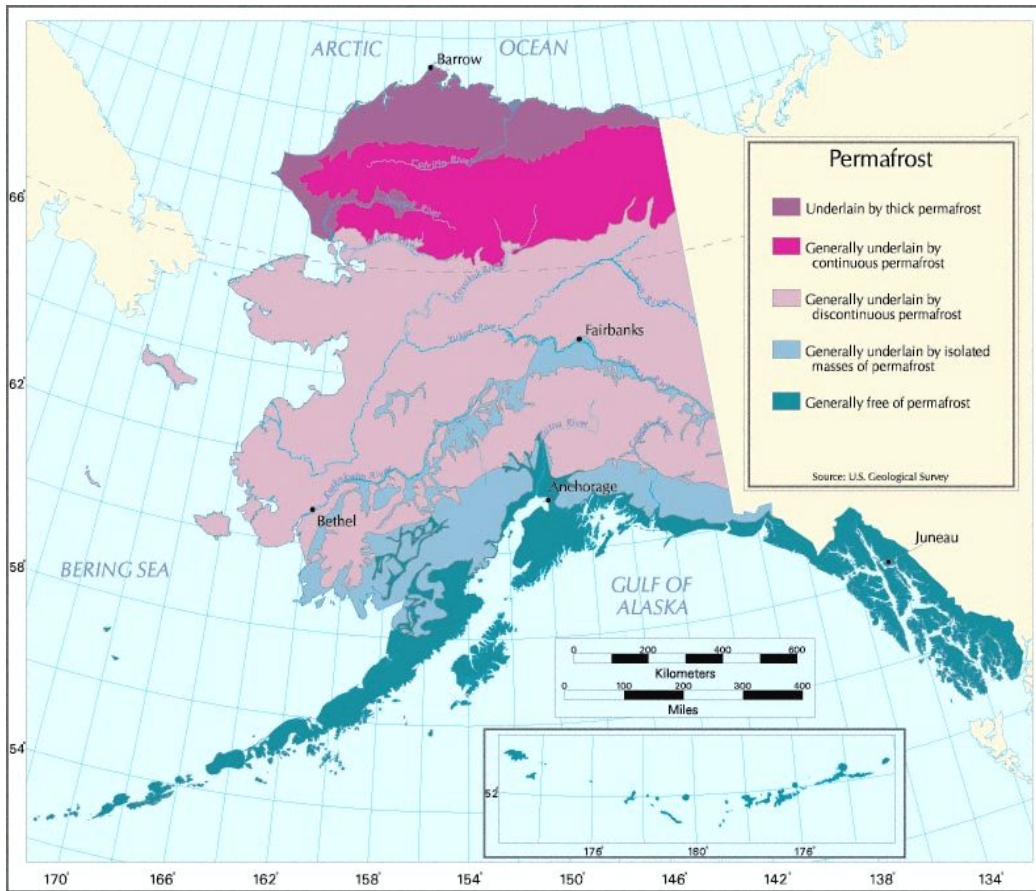
The distribution and character of permafrost is largely controlled by latitude; thick, continuous permafrost is more characteristic of the north, becoming thinner and discontinuous further south. This is illustrated in Figure 3-26. Elevation also influences permafrost; mountain ranges tend to contain permafrost that is thicker and more continuous than permafrost in lowland areas at the same latitude.

Permafrost is typically overlain by an 'active layer' in which the soil is repeatedly frozen and thawed with the changing seasons. Unfrozen ground exists beneath permafrost, and may exist within the permafrost mass. In more northerly latitudes the active zone is relatively thin and permafrost relatively thick. With more southerly latitudes the active zone becomes thicker and the permafrost thinner, eventually becoming discontinuous, as illustrated in Figures 3-26 and 3-27. The concentration of ice within permafrost is variable, and massive ice bodies may exist. Bedrock in permafrost regions is often badly fractured by frost action.

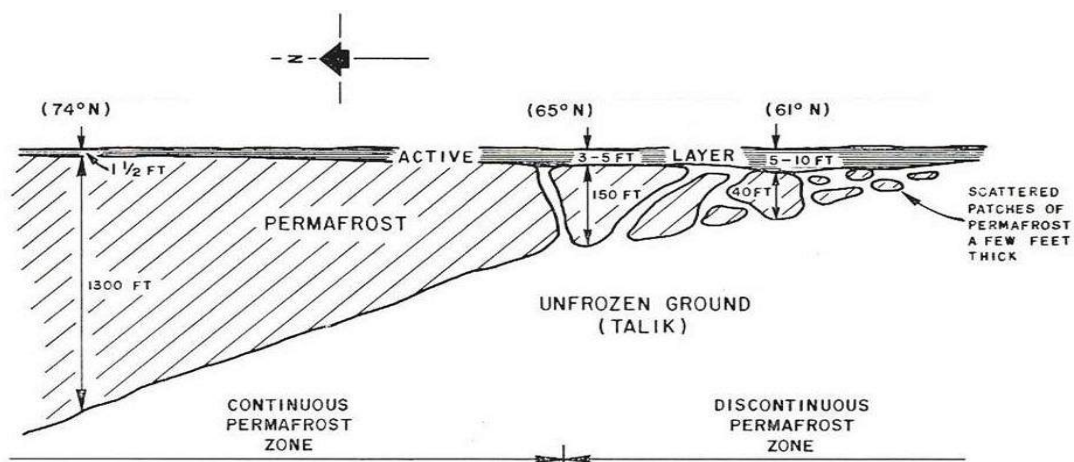
### ENGINEERING CHARACTERISTICS OF PERMAFROST

Frozen soils have higher strength, greater bearing capacity and are more impervious than the same soils in an unfrozen state. When soil pores are dominated by ice, the mechanical properties of the soil closely reflect that of the ice; they experience creep and strain hardening. Frozen soils also experience consolidation under loading, as ice at grain contacts is melted by the applied pressures and migrates. In frozen soils, long-term creep behavior is more important than the short-term deformation properties investigated in unfrozen soils.

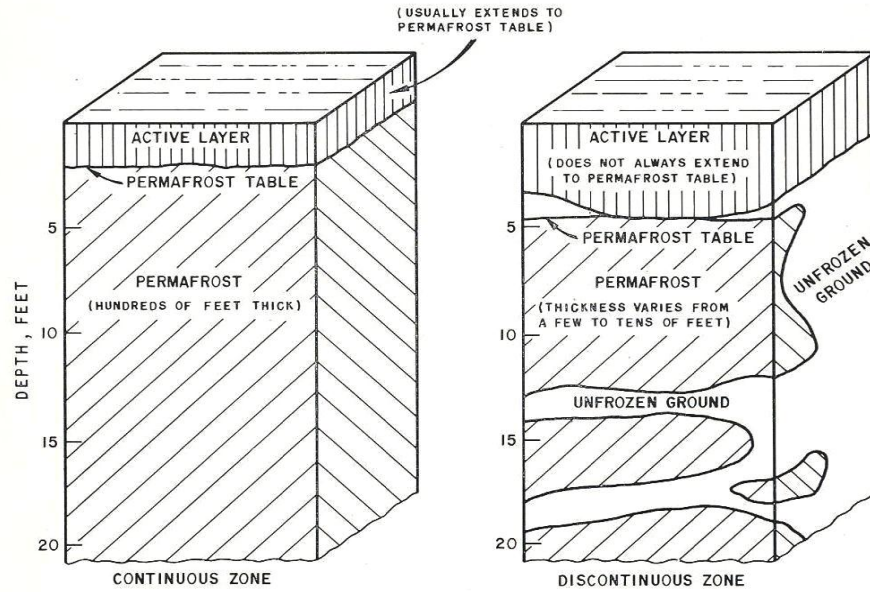




**Figure 3-25** Occurrence of permafrost in Alaska. From the United States Geological Survey website, based upon Ferrians' 'Permafrost Map of Alaska' (1965).



**Figure 3-26** North-south cross-section showing variation of permafrost thickness and continuity with latitude. Numbers in parentheses are degrees of latitude. Modified from Brown (1970).



**Figure 3-27** Block diagrams of typical soil profiles in permafrost. Left: Continuous permafrost, associated with more northerly latitudes. Right: Discontinuous permafrost, associated with more southerly latitudes. From Brown (1970).

When frozen soils are thawed they lose volume due to the phase change of ice to water, and the drainage of excess water. When thawed at a rate faster than can be accommodated by drainage, the build-up of pore water pressure may reduce the shear strength of the soil.

The active layer may support the growth of ice lenses during winter months, causing significant frost heave and subsequent thaw weakening. Frost action in the active layer is discussed in Section 3.4.

The thickness of the active layer and the depth of permafrost penetration are controlled by the thermal regime in the subsurface. Beyond climate and geothermal gradient, the thermal regime is greatly influenced by surface features (such as bodies of water, topography, drainage and vegetation) which can act as heat sinks or sources, or provide insulation. Actions which alter surface features (such as clearing of vegetation, draining of water bodies, excavating or grading of land, and installation of engineered structures) are likely to alter the thermal regime, changing the thickness of the active layer and possibly causing permafrost thaw.

Permafrost is a largely impermeable barrier to groundwater, causing water to move and collect within the active layer. The difficulty of percolation and subsurface drainage, coupled with seasonal snow melts, can induce high rates of surface erosion during spring months. Disruption of natural drainage conditions will likely affect the amount of water in the active layer, possibly promoting seasonal frost action.

The investigation and mitigation of seasonal frost action in the active layer in soils is dealt with in Section 3.4. This chapter deals with the investigation of permafrost, and the problem of its thawing.

## **SITE INVESTIGATION GOALS**

- a) Map the areal extent and depth of permafrost (through field reconnaissance, geophysical methods and aerial photography including Google Earth or other internet or printed aerial images)
- b) Model the thermal regime of the soil profile (through boring and temperature sensors)
- c) Assess the physical and mechanical properties of frozen and thawed soils (through field testing, sampling and laboratory testing)

## **SITE INVESTIGATION ACTIONS**

### **Mapping the Areal Extent and Depth of Permafrost**

In regions of continuous permafrost, avoidance is impossible and the emphasis of these actions is toward sounding the top and bottom of the permafrost layer, and locating massive ice bodies, ice-rich zones and unfrozen zones in the permafrost.

In regions of discontinuous permafrost, avoidance may be possible and is recommended if construction activities are likely to disrupt the thermal regime. In this case, the emphasis is toward mapping the areal extent of permafrost.

#### ***Field Reconnaissance and Aerial Photography***

Permafrost and frost action produce several types of geomorphic features, including polygonal ground, stone nets, solifluction sheets, thaw lakes, beaded drainage, ice wedges and pingos. The recognition of these features in aerial photography (Google Earth or other internet or printed aerial photos, including stereo-pairs), supported by field reconnaissance, is an indication of the existence of permafrost and its lateral extent.

#### ***Geophysical Methods***

The most popular geophysical methods in the investigation of permafrost are seismic refraction and galvanic resistivity. Airborne electromagnetic resistivity surveying for permafrost mapping has also been used successfully (Andersland and Ladanyi, 2004). Seismic refraction surveying allows exploration to a depth of about 30 meters. It is well suited to areas that are generally flat; delineating loose or fractured rock from sound rock, and delineating permafrost, large ice bodies and unfrozen ground. Galvanic resistivity surveys should be used as a compliment to seismic refraction surveys. They are well suited to delineating the water table, and can corroborate the boundaries of permafrost and ice bodies.

### **Modeling the Thermal Regime**

In order to design structures in permafrost areas it is essential that the thermal regime (the variation of temperature with depth) at the proposed site be characterized and understood. Ideally, the thermal regime at a site should be evaluated throughout the year to observe seasonal

fluctuations. It should be recognized that the end of the thawing cycle is in the fall; this is when the permafrost surface is lowest.

### ***Borings***

The purpose of borings in permafrost regions is to locate the permafrost table (the boundary between frozen ground below and unfrozen ground above). During drilling, the penetration of permafrost is usually more difficult than that of thawed soil. Such a drilling break may be difficult to discern in very dense materials, in which case it is necessary to measure the temperature of soil cuttings at regular depth intervals, immediately after they reach the surface. Drilling breaks or cuttings will only provide the depth of the permafrost table at a single point in time.

### ***Electronic Temperature Sensors***

Temperature sensors provide continuous, real-time data of subsurface temperatures. While being a costly option, these provide accurate quantitative data that allows for detailed modeling of the thermal regime such as that shown in Figure 3-28. Thermocouples or thermistors should be installed at regular depth intervals, in a back-filled hole. Sufficient time should be allowed between the installation of these instruments and the use of their data, to allow for reestablishment of the natural thermal regime.

### **Field Testing**

The purpose of field testing of frozen soils is to assess their engineering properties. Data from field testing may be more useful than that from laboratory testing, as the latter requires the removal and transit of undisturbed samples and does not account for the influence of large-scale heterogeneities such as ice lenses.

Most field methods developed for testing unfrozen soils can be applied to frozen soils, although equipment may need to be modified to deform and fail frozen soils. In frozen soils testing the focus is more toward long-term creep behavior, rather than the short-term deformation properties investigated in unfrozen soils.

- Pressuremeter Test (ASTM D4719)
- Plate Bearing Test (ASTM D1195)
- Performance of Piles in Permafrost Under Static Axial Load (ASTM D5780)
- Deep Static Cone Penetration Test (ASTM D3441)

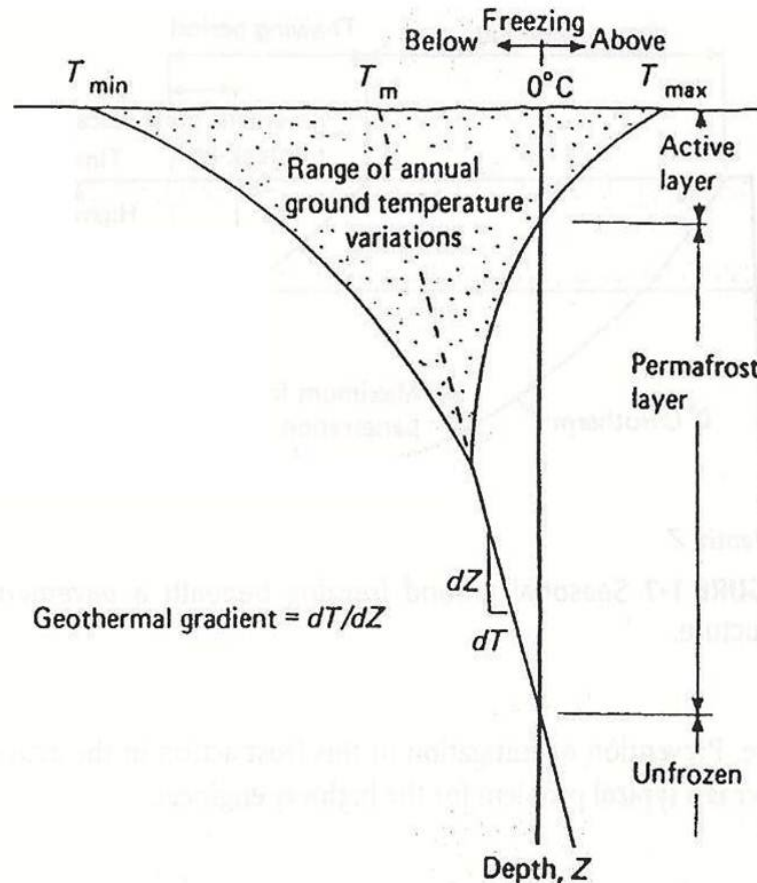
### **Sampling**

While the high strength of frozen soils makes them less susceptible to mechanical disturbance, it also makes tube-type samplers ineffective. Largely undisturbed samples can be retrieved by rotary coring operations, and power tools can be used to cut block samples. During coring or cutting operations the surface layer of the core or block may become thawed, thus the sample should be of sufficient dimensions that the thawed layer can be removed.

It is very important that thermal disturbance of samples is minimized. Samples must be protected from changes in temperature or loss of moisture during storage, transport and testing. Samples intended for salinity testing may be allowed to thaw, but the original moisture content must be preserved.

The location and depth of samples depends largely upon the nature of the planned works. Samples should be taken at regular intervals. It is advantageous if any simple laboratory tests can be performed on-site, thus negating the problem of sample transport.

**Figure 3-28** Cross section of a typical thermal regime in a permafrost region. Such a model can be constructed by monitoring the temperature fluctuations at specific depths in the soil profile, for a seasonal cycle. From this model the depths of the active layer and permafrost layer, and the geothermal gradient can be extrapolated.  $T_{min}$  = minimum annual temperature;  $T_{max}$  = maximum annual temperature;  $T_m$  = mean annual temperature. From Andersland and Ladanyi (2004).



### Laboratory Testing

- Creep Properties of Frozen Soil by Uniaxial Compression (ASTM D5520)
- Strength of Frozen Soil by Uniaxial Compression (ASTM D7300)
- Frost Heave and Thaw Weakening Susceptibility of Soils (ASTM D5918)
- Salinity of Soil Pore Water (ASTM D4542)
  - Dissolved salts in pore water lower its freezing temperature, thereby increasing the amount of liquid water in the soil and affecting the soil's mechanical properties.

### Interpretation of Field and Laboratory Test Results

The prediction of long-term soil behavior from laboratory or field testing is common practice. Such extrapolations in frozen soil, however, can be unreliable due to temperature and stress

variations, and various long-term soil phenomena. Long-term frozen soil behavior can also be modeled based upon an ‘effective stress’ approach, in which the expected soil state after complete stress redistribution and excess pore water pressure dissipation is considered (Andersland and Ladanyi, 2004).

The potential thaw weakening of a soil is expressed as a ‘bearing ratio’, assessed by comparing its bearing strength when frozen to its bearing strength when thawed.

The recognition of salinity of soil water is very important. If the salinity of soil water is likely to change between the sampling and construction phases, or during the lifetime of the structure, it follows that the ice content and the mechanical properties of the soil will change. By recognizing this possibility in the early phases of the project, problems can be avoided (Andersland and Ladanyi, 2004).

## **POSSIBLE MITIGATION OPTIONS**

- Avoidance (in regions of discontinuous permafrost)
- Excavation of frost susceptible materials from active layer (see Section 3.4)
- Prevention of permafrost thawing
  - Refrigeration
  - Insulation
  - Thermosiphons
  - Ventilated pads (for buildings and smaller installations)
  - Minimizing disturbance of natural vegetation or surface water
- Anchoring of foundations on bedrock, or at depth beyond the maximum expected thaw penetration
- Design to accommodate thaw-settlement

## **RECOMMENDED AND CITED REFERENCES**

Andersland, O.B. and Ladanyi, B. 2004. Frozen Ground Engineering, 2<sup>nd</sup> Ed. The American Society of Civil Engineers, John Wiley and Sons.

Brown, R.J.E. 1970. Permafrost in Canada. University of Toronto Press.

Calmels, F., Horton, B., Roy, L.P., Lipovsky, P., and Benkert, B. 2016. Assessment of Risk to Infrastructure from Permafrost Degradation and a Changing Climate, Ross River. *Northern Climate ExChange, Yukon Research Centre, Yukon College*. [electronic document]. Available from [https://www.yukonu.ca/sites/default/files/inline-files/ross\\_river\\_permafrost\\_low-res\\_Final\\_0.pdf](https://www.yukonu.ca/sites/default/files/inline-files/ross_river_permafrost_low-res_Final_0.pdf)

Ferrians, O.J. 1965. Permafrost Map of Alaska. U.S. Geological Survey Miscellaneous Geologic Investigations Map 1-445.

Ferrians, O.J., Kachadoorian, R. and Greene, G.W. 1969. Permafrost and Related Engineering Problems in Alaska. U.S. Geological Survey Professional Paper 678.



GAPHAZ 2017: Assessment of Glacier and Permafrost Hazards in Mountain Regions – Technical Guidance Document. Prepared by Allen, S., Frey, H., Huggel, C. et al. Standing Group on Glacier and Permafrost Hazards in Mountains (GAPHAZ) of the International Association of Cryospheric Sciences (IACS) and the International Permafrost Association (IPA). Zurich, Switzerland / Lima, Peru, 72 pp. Available from:  
[https://gaphaz.org/files/Assessment\\_Glacier\\_Permafrost\\_Hazards\\_Mountain\\_Regions.pdf](https://gaphaz.org/files/Assessment_Glacier_Permafrost_Hazards_Mountain_Regions.pdf)

Johnston, G.H. 1981. Permafrost: Engineering Design and Construction. Associate Committee on Geotechnical Research, National Research Council of Canada. John Wiley and Sons.

Péwé, T.L. 1983. Alpine Permafrost in the Contiguous United States: A Review. *Arctic, Antarctic and Alpine Research*, Volume 15, No. 2, pp. 145-456. University of Colorado at Boulder.

Tart, R.G., Jr. 1996. Permafrost. *In* Landslides: Investigation and Mitigation (Chapter 25). Transportation Research Board, Special Report 247. National Research Council.

### 3.13 SALINE SOILS

#### THREATS POSED TO ENGINEERED WORKS

- Corrosion of metals below ground level
- Long-term surface settlement, in soils containing high proportions of solid salt
- Development of collapse sinkholes

#### FIELD INDICATORS OF SALINE SOILS

- Direct identification of salts in soils
  - In the solid state, salts are crystalline and usually white or opaque
  - They may form a white crust on the land surface
  - They may be identifiable in soils below the surface
- Vegetation is adversely affected by soil salinity
  - Barren spots in otherwise uniform vegetation
  - Stunted growth
- Piping/dissolution features
- Sinkholes/depressions

Micro-crystalline salts, salts in low abundance, and salts in solution in groundwater may be difficult to identify by visual inspection. In such cases, soil tests may be required to identify saline soils.

#### ENGINEERING CHARACTERISTICS OF SALINE SOILS

The dissolution of soluble salts produces charged ions that promote the corrosion of ferrous metals by enhancing electrical conductivity (reducing resistivity) within the soil. Electrical resistivity measurements are widely used to assess soil corrosivity.

The corrosivity of a soil is also influenced by the degree of saturation. For a given soil; higher moisture content tends to increase the general rate of corrosion. Corrosive soils with low moisture content are likely to produce a localized ‘pitting’ type of corrosion.

Long-term surface settlement may occur following the continual wetting of soils that contain a high percentage of solid salts. This phenomenon is most often seen in soils derived from evaporite bedrock. The progressive leaching of salts increases the soil’s void ratio, creating the potential for compaction and surface settlement. The amount of surface settlement is largely dependent upon the volume of salt leached from the soil. The rate of leaching can be rapid, if the soil is subjected to high volumes of through-flowing water.

There are presently no standardized methods for assessing the volume fraction of solid salts that may be leached from a soil, and hence estimating the associated surface settlement. In agriculture, the total salt concentration is often estimated based on the total dissolved solids measured in a mixture of soil and water. However, in soils that are shown to be rich in salts



(either by visual identification or resistivity testing), it should be recognized that long-term settlement may be a hazard.

## **OCCURRENCE OF SALINE SOILS**

Salts in soil originate primarily from the breakdown of natural minerals. They are dispersed and transported in ground and surface water. In most cases, soils below the water table are not significantly saline.

Soil matrix suction can draw water from the underlying water table, transferring dissolved salts to near-surface soils where, due to evaporation, they are precipitated. In arid and semi-arid regions this process is ongoing for long periods of time and serves to concentrate salts in near-surface soils.

Percolation of water through soils can leach salts from areas of higher elevation and concentrate them in low-lying areas, or from high permeability layers to less permeable horizons.

Salts can also be introduced to soils in irrigation water. Irrigated land may become saline in arid or semi-arid regions, where the amount of water lost to evaporation is significantly higher than the amount that percolates down to the water table. This causes salts to be precipitated at a faster rate than they are leached out, leading to concentration of salts in the near-surface.

Salt in soils may be residual, having originated from evaporite bedrock (halite and anhydrite). Residual saline soils only develop in arid or semi-arid regions; in wetter regions the salt component of the soil is dissolved and leached out. The problem of surface settlement due to salt leaching is associated with soils derived from evaporite bedrock

Saline soils often develop in coastal regions, due to the ingress of sea water through tidal action or underground aquifers, or through wind transport of salt-water spray. In regions where the groundwater is saline, soils below the water table may be significantly saline.

Salts are also introduced to the soil by road de-icing activities. In cold climates, such as at northerly latitudes and at high elevations, the amount of salt infiltrating soils in the proximity of transport routes can be considerable.

Consequently:

- Saline soils are usually found in arid and semi-arid regions, commonly in the near-surface, and may also be associated with one or more of the following:
  - A shallow water table
  - Irrigated land
  - Evaporite bedrock
- Saline soils may exist in coastal regions, where they may occur below the water table.
- Saline soils may exist in proximity to transport routes in cold regions.

## **SITE INVESTIGATION GOALS**

- a) Assess the thickness, lateral extent, and corrosivity of saline soils (through visual inspection, sampling, field testing and laboratory testing of soils at the surface, in trenches and, if necessary, borings)

## **SITE INVESTIGATION ACTIONS**

### **Trenches**

Trenching allows near-surface soils to be viewed and sampled. In arid or semi-arid environments, salts are commonly concentrated in near-surface soils. The spacing of trenches depends upon the nature of the planned works and the lateral variability of the soil profile. Special attention should be paid to suspected areas of high-salinity soils, and proposed locations of underground works.

### **Borings**

Borings allow for the investigation of soils at depth. This may be unnecessary for shallow works, or in regions where saline soils are only expected to occur in the near-surface. The depth and spacing of borings depends upon the planned works, the lateral variability of the soil profile, and the expected distribution of saline soils (based upon the environment and the likely mechanisms of salt concentration). Special attention should be paid to suspected areas of high-salinity soils, and proposed locations of underground works.

### **Visual Inspection**

Visual inspection aims to identify saline soils. Visual indicators of saline soils are detailed earlier in this chapter. Salinity in near-surface soils is generally easier to detect than in soils at depth, because of the effect that near-surface soils have on vegetation. Low levels of salinity, and saline soils from depth, may be difficult to identify without conducting soil tests.

### **Sampling**

Samples should be taken of all soil units encountered in subsurface investigations, and at regular intervals. The frequency and distribution of samples depends upon the degree of salinity of the soils, and the nature of the planned works. Highly saline soils, and soils expected to accommodate important metal construction components, should be sampled more comprehensively (Elias et. al, 2009). Disturbed samples are sufficient for the assessment of soil corrosivity, for which electrical resistivity tests are performed on a saturated paste.

### **Field Testing**

Field testing of saline soils aims to provide ‘real-time’ information of soil resistivity, during the ongoing soil investigation, so that the distribution of saline soils can be understood and the

investigation streamlined accordingly. Generally, fewer samples will be tested in the field than are taken for analysis in the laboratory.

Assessment of soil corrosivity:

- Measurement of soil resistivity (Wenner four-electrode method) (ASTM G57)

### Laboratory Testing

Assessment of soil corrosivity:

- Minimum soil resistivity (laboratory) (AASHTO T 288)

### Interpretation of Field and Laboratory Results

**Table 3-8** Effect of soil-resistivity on corrosion of metal (NCHRP, 1998).

Aggressiveness	Resistivity (ohm-cm)
Very corrosive	< 700
Corrosive	700 – 2,000
Moderately corrosive	2,000 – 5,000
Mildly corrosive	5,000 – 10,000
Non-corrosive	> 10,000

### POSSIBLE MITIGATION OPTIONS

- Avoidance of saline soils
- Excavation of saline soils
- Use of materials designed for aggressive environments.
- Avoidance of wetting of saline soils
  - to limit the aggressiveness of corrosion
  - to minimize leaching and potential settlement

### RECOMMENDED AND CITED REFERENCES

Elias, V., Fishman, K.L., Christopher, B.R. and Berg, R.R. 2009. Corrosion/Degradation of Soil Reinforcements for Mechanically Stabilized Earth Walls and Reinforced Soil Slopes. U.S. Department of Transportation, Report No. FHWA-NHI-09-087.

Food and Agriculture Organization of the United Nations (FAO), Soil Resources Management and Conservation Service. 1988. Saline Soils and Their Management. FAO Soils Bulletin 39. [www.fao.org/docrep/x5871e/x5871e00.htm](http://www.fao.org/docrep/x5871e/x5871e00.htm)

National Cooperative Highway Research Program (NCHRP). 1998. Service Life of Drainage Pipe. Synthesis Report SYH250. Transportation Research Board.

Richards, L.A. 1954. Diagnosis and improvement of Saline and Alkali Soils. U.S. Department of Agriculture, Handbook No. 60.

Roberge, P.A. 2019. Handbook of Corrosion Engineering, 3<sup>rd</sup> ed. McGraw-Hill Education, 800 p.

Shahid, Shabbir A., Zaman, Mohammad, and Heng, Lee. 2018. Salinity and Sodicity Adaptation and Mitigation Options. In: *Guideline for Salinity Assessment, Mitigation and Adaptation Using Nuclear and Related Technology*, Springer, Cham.  
<https://doi.org/10.1007/978-3-319-96190-3>

### 3.14 GYPSIFEROUS SOILS

#### THREATS POSED TO ENGINEERED WORKS

- Short term or long-term surface settlement, following wetting of soils
- Development of collapse sinkholes
- Production of sulfate soils (see Section 3.15)
  - Corrosion of concrete
  - Volume expansion of soils when mixed with lime

#### FIELD INDICATORS OF GYPSIFEROUS SOILS

- Identification of gypsum in soils
- Piping/collapse features
- Sinkholes/dissolution features
- Vegetation is often sparse in gypsiferous soils

#### ENGINEERING CHARACTERISTICS OF GYPSIFEROUS SOILS

Gypsum (calcium sulfate) is soluble in water. The dissolution of gypsum can be rapid, especially if soils are subjected to high rates of through-flowing water, and may cause short-term and/or long-term surface settlement.

Short-term surface settlement usually occurs following the wetting of soils in which gypsum is a cementing agent. The gradual dissolution of the cementing agent leads to collapse of the soil structure.

Long-term surface settlement may occur following continual wetting of soils that contain a high percentage of gypsum. The progressive leaching of gypsum from the soil increases porosity and void ratio. The amount of settlement is largely dependent upon the percentage of gypsum in the soil.

Gypsiferous soils often contain high concentrations of calcium ions, sodium sulfate and magnesium sulfate, all of which are corrosive to the cement in concrete (see Section 3.15). When gypsiferous soils are mixed with lime-based (CaO-rich) stabilizers, the mineral ettringite is likely to form, causing expansion and possible surface heave (see Section 3.15).

#### OCCURRENCE OF GYPSUM IN SOILS

Gypsum in soils may be residual (having originated from gypsum bedrock) or pedogenic (having formed in the soil as a precipitate from groundwater). The accumulation or formation of significant quantities of gypsum usually requires an existing concentration of gypsum in the area, usually as bedrock.

Soil matrix suction can draw water from the underlying water table, transferring dissolved sulfate ions to near-surface soils where, if evaporation is significant, they are precipitated as gypsum.

Percolation of water through soils can leach gypsum from areas of higher elevation and concentrate it in low-lying areas, or from high permeability layers to less permeable horizons. For gypsum to remain and accumulate in soils, the through-flow of groundwater must be limited.

Consequently:

- Gypsiferous soils usually develop in arid and semi-arid regions where abundant sources of gypsum exist.
- Gypsum often accumulates on the fringes of terraces, detrital cones and slope-bases.
- Pedogenic gypsum is likely to be concentrated in near-surface soils.

Gypsum in soils may exist in several forms including:

- Discrete crystals (alone or in small agglomerations)
- Microcrystalline gypsum (often as a soil cementing agent)
- Gypsiferous sand accumulated at the surface in desert environments, due to its relatively low density

## **SITE INVESTIGATION GOALS**

- a) Determine the thickness and extent of gypsiferous soils (through visual inspection of soils at the surface, in trenches and, if necessary, borings)
- b) Assess the potential for short-term soil settlement (through sampling and laboratory testing)
- c) Assess the potential for long-term surface settlement (through sampling and laboratory testing)

## **SITE INVESTIGATION ACTIONS**

### **Visual Inspection of Soils at the Surface and in Trenches and Borings**

Visual inspection of soils allows for the identification of gypsum and qualitative estimation of its abundance, with an aim to delineating its extent both laterally and vertically within the soil profile. Procedures for the identification of gypsum in the field are detailed in Rock and Mineral Identification for Engineers (1991).

Solid gypsum is rare in soils below the water table, but is often concentrated in the near-surface. The depth of investigation need not be beyond the water table, bedrock surface, or a reasonable depth considering the planned engineering works and subsequent land use.

Trenches are useful in gaining access to subsurface soils. If deeper investigation is required borings may be used; gypsum can be identified in drill cuttings as they reach the surface. Trenches and/or borings should be located to identify the lateral extent of gypsiferous soils. In the absence of geomorphic indicators or local knowledge a grid-pattern or equivalent may be used. If geomorphic features can be identified (such as detrital cones or terraces), or if local knowledge and experience is available, the investigation may be streamlined accordingly.

## Sampling

Undisturbed samples are necessary for the consolidometer test (pertinent to short-term soil settlement). Retrieving quality undisturbed samples in gypsiferous soils that are fairly porous (relying on cementing agents for strength) can be difficult. Better quality samples can be retrieved using a large-diameter pitcher-type sampler with a lined tube, or by cutting block samples from trenches or pits (ASTM 7015).

Disturbed samples are sufficient for the determination of percent gypsum in the soil (pertinent to long-term surface settlement).

## Laboratory Testing

Assessment of short-term surface settlement potential:

- Consolidometer Test (AASHTO T 216; ASTM D2435)(modified)
  - The undisturbed sample is subjected to a specific load, then flooded with water and allowed to saturate. The magnitude of resulting hydrocompaction is measured.

Assessment of long-term surface settlement potential:

- Gypsum aqueous extraction (NRCS Soil Survey Lab Method Code 4E2)

## Interpretation of Laboratory results

From the consolidometer test for short-term surface settlement potential:

$$\text{Collapse Potential} = \frac{\text{Change in height of sample}}{\text{Original height of sample}}$$

The magnitude of possible surface collapse can be broadly approximated by multiplying the collapse potential (CP) by the thickness of the gypsiferous soil layer. Experimental CP values are specific to the experimental load applied; test loads should be chosen to reflect the planned loads to be applied to the soil. The CP value of collapsible soils (Section 3.9) can be used to approximately classify them according to the severity of the collapse hazard (Tables 3-2 and 3-3). While these classification schemes do not strictly apply to gypsiferous soils, they may be useful as guidelines.

The gypsum aqueous extraction test can be used to estimate the long-term surface settlement by converting the weight percent of gypsum in the soil to a volume percentage. The volume percentage of gypsum is then multiplied by the total thickness of the gypsiferous soil layer to estimate the long-term possible settlement (assuming that all the gypsum can presumably be leached out from the soil over time).

## POSSIBLE MITIGATION OPTIONS

- Avoidance of gypsiferous soils
- Avoidance of wetting of gypsiferous soils, during the entire lifespan of the structure
- Excavation of gypsiferous soils
- Dynamic or vibratory compaction, to induce short term surface settlement before construction
- Appropriate foundation designs (deep foundations, spread footings, grid foundations etc.)

## RECOMMENDED AND CITED REFERENCES

United States Department of Transportation (USDOT). 1991. Rock and Mineral Identification for Engineers. U.S. Department of Transportation, Federal Highway Administration, Report No. FHWA-HI-91-025.

Food and Agriculture Organization of the United Nations (FAO), Soil Resources Management and Conservation Service. 1990. Management of Gypsiferous Soils. FAO Soils Bulletin 62. <http://www.fao.org/docrep/t0323e/t0323e00.htm>

Lovekin, J.R., and Higgins, J.D. 2003. Major Geologic Hazards Along the Roaring Fork River Near Glenwood Springs, Colorado. *In*: Boyer, D.D., Santi, P.M., and Rodgers, W.P. (eds.) Engineering Geology in Colorado – Contributions, Trends, and Case Histories. Association of Environmental and Engineering Geologists (AEG) Special Publication No. 15.

White, J.L., and Greenman, C. 2008. Gypsiferous Soils and Soils Derived From Evaporite Bedrock. *In* Collapsible Soils in Colorado. Colorado Geological Survey, Engineering Geology 14

White, J.L. 2003. Evaporite Karst Subsidence Hazards in Colorado. *In*: Boyer, D.D., Santi, P.M., and Rodgers, W.P. (eds.) Engineering Geology in Colorado – Contributions, Trends, and Case Histories. Association of Environmental and Engineering Geologists (AEG) Special Publication No. 15.



### **3.15 SULFATE SOILS**

#### **THREATS POSED TO ENGINEERED WORKS**

- Corrosion of concrete
- Volume expansion of soils when mixed with lime

#### **FIELD INDICATORS OF SULFATE SOILS**

- Deterioration of concrete that is in contact with soils
- Heaving of structures emplaced on lime-stabilized fill containing soil

#### **MECHANISM OF EXTERNAL SULFATE ATTACK OF CONCRETE (ESA)**

Certain metal sulfates are corrosive to Portland cement paste (notably calcium sulfate, sodium sulfate, magnesium sulfate and potassium sulfate). Corrosion typically occurs underground when ground water containing sulfate ions contacts and penetrates the concrete. This mechanism is known as external sulfate attack (ESA).

The effects of ESA vary in type and severity but commonly include:

- Extensive cracking
- Expansion
- Loss of bond between the cement paste and aggregate
- Alteration of cement paste composition

The effect of these changes is an overall loss of concrete strength. Chemical and structural deterioration of concrete also puts reinforcing steel contained within at risk from corrosion or damage.

#### **MECHANISM OF SULFATE SOIL EXPANSION – ETTRINGITE FORMATION**

The addition of lime-based (CaO-rich) stabilizers to soils rich in sulfate minerals creates conditions in which the mineral ettringite is likely to form. The structure of ettringite incorporates large quantities of water, and its formation causes considerable volume expansion.

#### **OCCURRENCE OF SULFATES IN SOILS**

Sulfates in soils originate primarily from the breakdown and dissolution of natural minerals (notably gypsum, anhydrite and pyrite, among others). Fertilizers and industrial effluents also contribute sulfate ions to soil. The amount and location of sulfates in a soil depends upon the soil and bedrock compositions, the topography, the climate, and the processes of mobilization and concentration taking place. Sulfate distribution in soils is rarely uniform, but more often concentrated in seams and stratified pockets.

Soil matrix suction can draw water from the underlying water table, transferring dissolved sulfate ions to near-surface soils where, if evaporation is significant, they are precipitated. Percolation of water through soils can leach sulfates from areas at higher elevation and concentrate them in low-lying areas, or from high permeability layers to less permeable horizons. For sulfates to remain and accumulate in soils, the through-flow of groundwater must be limited (Little and Nair, 2009).

Consequently:

- Sulfate soils exist predominantly in arid and semi-arid environments
- Sulfate soils are usually found in the region of sulfate-bearing rock, or on land that has been irrigated or fertilized
- Sulfates are likely to be concentrated in near-surface soils
- Sulfates are likely to be concentrated in low-lying areas

## **SITE INVESTIGATION GOALS**

- a) Identify possible locations of sulfate concentration in soils (through review of existing information, relevant experience and field testing)
- b) Assess sulfate levels in soils (through sampling and laboratory testing)

## **SITE INVESTIGATION ACTIONS**

### **Locating Sulfate Concentrations**

Sulfate concentrations in the site area need to be identified so that they can be sampled. Sulfate distribution in soils is rarely uniform, but more often concentrated in seams and stratified pockets.

United States Department of Agriculture (USDA) soil survey reports, experience in adjacent sites or similar sites (with regard to geology, climate and topography), and expert experience of sulfate soil behavior can be used to predict where sulfates may concentrate.

Soil conductivity measurements give a good approximation of dissolved salts in soils and thus can help to locate sulfate seams or pockets (Texas Department of Transportation, 2005a).

### **Sampling**

Samples should be taken of all soil units encountered in the site investigation, including soils thought to contain sulfate concentrations, and at locations relevant to planned foundation and concrete emplacement. Borings can be made to retrieve samples from depth, if required. Disturbed samples are sufficient for the assessment of sulfate content.

### **Laboratory Testing**

Water-soluble sulfate ions are the active agent in both ESA and ettringite formation:

- Water-Soluble Sulfate Ion Content in Soil (ASTM C1580)

The actual amount of expansion can be approximated by a one-dimensional swell test conducted on a sample of compacted, lime-treated sulfate soil:

- One-dimensional swell test (ASTM D4546)

### **Interpretation of Laboratory Results**

The concentration of water soluble sulfates in the soil can be used to classify the soil's potential for ESA, as shown by Table 3-9. The concentration of water soluble sulfates in the soil can also be used to plan stabilization treatments, as shown by Table 3-10.

The findings of the one-dimensional swell test of lime-treated soil will indicate the swelling pressure (at constant volume) or volume change (under a constant confining pressure) produced by ettringite formation.

### **POSSIBLE MITIGATION OPTIONS**

General:

- Avoidance
- Maintenance of dry soils to inhibit sulfate dissolution and migration, and ettringite formation.
- Excavation of sulfate soils
- Blending of low-sulfate materials to reduce overall sulfate concentration

ESA mitigation:

- Following ACI guidelines for design and mixing specifications of concrete for sulfate environments.

Heave mitigation:

- Incorporating a mellowing period before compaction. During this time much of the sulfates are dissolved and much of the ettringite is formed, minimizing soil expansion after compaction. The mellowing time and optimum water content are determined through experimental procedure (Texas Department of Transportation, 2005b).

**Table 3-9** Classification of severity of sulfate environment based upon concentration of water-soluble sulfates, adapted from the American Concrete Institute (2011).

Severity of Sulfate Environment	Concentration of Water-Soluble Sulfates	
	In Soil (% by weight)	In Water (ppm)
Class 0 – Mild	< 0.1	<150
Class 1 – Moderate	0.1 to 0.2	150 to 1,500
Class 2 – Severe	0.2 to 2.0	1,500 to 10,000
Class 3 – Very Severe	> 2.0	> 10,000

**Table 3-10** Guidelines for recommended lime-treatment of soils based upon concentration of water-soluble sulfates, adapted from the Texas Department of Transportation (2005b).

Concentration of Water-Soluble Sulfates (ppm)	Recommended Stabilization Treatment
< 3,000	Traditional Treatment: Lime stabilization should not be of significant concern. This does not mean that the potential for expansion does not exist, but that level of expansion due to ettringite formation should be manageable and detrimental expansions can be limited by adequate mixing and moisture treatment. If soluble sulfates are detected, then the use of lime slurry is recommended in lieu of the use of calcium oxide.
3,000 to 8,000	Modified Treatment: TxDOT recommends the use of lime in a single application. The use of an extended mellowing period before compaction, during which the water content must be maintained at least 3 percent above the optimum, is recommended. The mellowing time and optimum water content are determined through experimental procedure by monitoring the residual sulfate concentration in representative samples until they drop below 3,000 ppm.
> 8,000	Alternative Treatments: Removal and replacement with borrow soils. Blending of low-sulfate materials to reduce overall sulfate concentration. Use of additives.

## RECOMMENDED AND CITED REFERENCES

American Concrete Institute (ACI). 2011. Guide to Durable Concrete. ACI Manual of Concrete Practice: Part 1. American Concrete Institute, Publication No. ACI 201.2R-01.

Little, D.N., and Nair, S. 2009. Recommended Practice for Stabilization of Sulfate Rich Subgrade Soils. National Cooperative Highway Research Program, Web-Only Document 145 (Task Report for NCHRP Project 20-07).

[http://onlinepubs.trb.org/onlinepubs/nchrp/nchrp\\_w145.pdf](http://onlinepubs.trb.org/onlinepubs/nchrp/nchrp_w145.pdf)

Reid, J. Murrey. 2012. "Chapter 37: Sulfate/acid soils". In *ICE Manual of Geotechnical Engineering, Volume 1 - Geotechnical Engineering Principles, Problematic Soils and Site Investigation*, John Burland, Tim Chapman, Hilary Skinner, and Michael Brown eds. London: ICE Publishing.

Texas Department of Transportation. 2005a. Conductivity Test for Field Detection of Sulfates in Soil. Texas Department of Transportation, Test Procedure Designation TEX-146-E.

Texas Department of Transportation. 2005b. Guidelines for Treatment of Sulfate-Rich Soils and Bases in Pavement Structures. Texas Department of Transportation, Report No. TxDOT 09-2005.

## 3.16 ACID SULFATE SOILS

### THREATS POSED TO ENGINEERED WORKS

- Acid corrosion and degradation of metals and concrete
- External sulfate attack of concrete, through precipitation of sulfates (see Section 3.15)
- Heaving of lime-treated fills, through precipitation of sulfates (see Section 3.15)
- Environmental damage due to acidification and leaching of heavy metals

### FIELD INDICATORS OF ACID SULFATE SOILS

Potential acid sulfate soils:

- Waterlogged soils, often with a sulfurous smell
  - Soft, sticky, blue-grey to dark greenish-grey muds
  - Grey to dark grey silty sands
  - Black iron monosulfide (“black ooze”)
  - Peat or peaty soils
- Contain iron sulfide minerals, predominantly pyrite

Actual acid sulfate soils:

- Dead or stunted vegetation
- Iron staining of water and drainage surfaces, iron oxide mottling of exposed soil
- Yellow jarosite in seams, old root channels and on exposed surfaces. Jarosite requires very acidic conditions to form and is one of the most conclusive field indicators that iron sulfides in the soil are forming sulfuric acid.
- Sulfurous smell
- Acidic groundwater and run-off (pH < 5.5)
- Corrosion of metals and concrete
- Presence of iron sulfide minerals, predominantly pyrite

Pyrite occurs most often as small, disseminated grains that have a cubic shape, a pale brassy-yellow color (tarnishing to grey with exposure to oxygen) and a metallic luster. Procedures for the identification of pyrite in the field are detailed in *Rock and Mineral Identification for Engineers* (1991).

### OCCURRENCE OF ACID SULFATE SOILS

Acid sulfate soils commonly occur in low-lying coastal areas, salt marshes, floodplains, swamps and estuaries where salt-water facilitates the formation and deposition of metal sulfides in an anoxic (oxygen-less) environment. As long as the soils remain saturated and are not exposed to air, they do not become acidic, remaining as potential acid sulfate soils.

If potential acid sulfate soils are buried and lithified they form sulfide rock, which may pose a threat of acid rock drainage when exposed (see Section 3.17). Residual soils above sulfide rock may be acidic or potentially acidic.

## **PROCESSES OF SULFATE SOIL ACIDIFICATION**

When iron sulfide minerals (predominantly pyrite) in soils are exposed to air they oxidize to form sulfuric acid. The process of pyrite oxidation can be initiated by the draining or excavating of pyrite-bearing soils, or by a lowering of the water table.

Acidic conditions can mobilize iron, aluminum and heavy metals from minerals in the soil. Sulfuric acid also reacts with calcium carbonates to form sulfate salts, possibly leading to swelling of soils and corrosion of concrete (see Section 3.15). Environmental damage due to acidification and leached heavy metals are major concerns; groundwater systems and ecosystems can be irreversibly damaged.

## **SITE INVESTIGATION GOALS**

- a) Identify actual and potential acid sulfate soils, and delineate their lateral and vertical extent (through borings, visual inspection and field testing)
- b) Quantify the existing and potential soil acidity (through sampling and laboratory testing)

## **SITE INVESTIGATION ACTIONS**

### **Borings**

Borings aim to identify actual and potential acid sulfate soils, to delineate their lateral and vertical extent, and to obtain samples for field and laboratory testing. The depth and spacing of borings largely depends on the extent of the planned works. The concentration of sulfides in soil can be variable across a site.

Obtaining continuous soil samples will aid in identification of the actual and potential acid sulfate soil horizons. A gouge auger (hand auger) is a useful tool if the soils are shallow and soft enough.

### **Visual Inspection and Field Testing**

The purpose of visual inspection and field testing in acid sulfate environments is to identify actual and potential acid sulfate soils, and to delineate their lateral and vertical extent. Actual and potential acid sulfate soils often occur in the same soil profile, with actual overlying potential.

A pH peroxide test ( $\text{pH}_{\text{FOX}}$ ) can be conducted on soil samples in the field to qualitatively indicate the presence of any oxidizable sulfur (potential acidity). A portable electronic potentiometer can be used to determine the field pH of a soil-water paste (actual acidity).

These field tests alone are generally not conclusive, as other soil constituents such as organics or fertilizers can contribute to sulfur content and acidity. However, when combined with field observations and knowledge of the general environment and site history, field testing provides important information.

### ***Potential acid sulfate soils***

Potential acid sulfate soils display the field indicators described above. A pH peroxide test of potential acid sulfate soils will indicate the presence of oxidizable sulfur. Potential acid sulfate soils may have a field pH that is acidic or alkaline, depending upon their degree of oxidation (Government of Western Australia, Department of Environment and Conservation, 2015a).

### ***Actual acid sulfate soils***

Actual acid sulfate soils display the field indicators described above. The top of actual acid sulfate soils are marked by an oxidation horizon, often with orange mottling of iron oxide. A pH peroxide test of actual acid sulfate soils will positively indicate the presence of oxidizable sulfur. Field pH testing of actual acid sulfate soils will return a pH of 4 or lower (Government of Western Australia, Department of Environment and Conservation, 2015a).

## **Sampling**

Samples should be taken at regular depth intervals through the soil profile. Samples should be taken of all soil units encountered and from zones of particular interest. Samples may be disturbed, since the chemical content is more important than soil strength to evaluate acidity.

## **Laboratory Testing**

The aim of laboratory testing of soils from acid sulfate environments is to quantitatively assess their net acidity in order to plan mitigation actions.

$$\text{Net Acidity} = \text{Existing Acidity} + \text{Potential Acidity}$$

To quantify existing acidity:

- pH of Soils (ASTM D4972)
- pH of Soils for Corrosion Testing (AASHTO T 289; ASTM G51)
- pH of Peat Materials (ASTM D2976)

To quantify potential acidity:

- Total Sulfur Content of Soils (British Standards Institution BS 1377-3)
- Suspension Peroxide Oxidation Combined Acidity and Sulfate Method (SPOCAS) (ISO 14388-3:2014)
- Chromium Reducible Sulfur Method (SCR) (ISO 14388-2:2014)



The SPOCAS and  $S_{CR}$  methods are more accurately indicative of potential acidity in acid sulfate soil environments than the Total Sulfur method.

### **Interpretation of Laboratory Results**

The results of quantitative laboratory analysis of acid sulfate soils, aside from characterizing soils at the site, are used primarily to calculate the amount of alkaline stabilizing agent necessary to counteract the net acidity. A general relationship is as follows:

$$\text{Stabilizing Agent Required (kg/m}^3 \text{ of soil)} = A \times B \times C \times D \times E$$

Where

- A = Bulk density of soil (ton/m<sup>3</sup>)
- B = Net acidity (Kg of sulfuric acid/ton of soil). Calculated as (% Sulfur, from laboratory tests) x (30.59).
- C = Stoichiometric conversion factor. Defines the mass of stabilizing agent needed to neutralize a unit mass of sulfuric acid. Depends upon the specific agent used.
- D = Effective neutralizing value. Represents the physical efficiency of the neutralization process in the field. Depends upon factors such as the particle size distribution of the soil, and the solubility of the neutralizing agent.
- E = Safety factor.

(Government of Western Australia, Department of Environment and Conservation, 2015b)

### **POSSIBLE MITIGATION OPTIONS**

Due to the potential for severe environmental degradation, as well as corrosion to engineering materials, acid sulfate soils should be avoided wherever possible. This extends to avoidance of interference with the existing groundwater, drainage and vegetative conditions in regions containing potential or actual acid sulfate soils.

If avoidance is not possible, the following guidelines should be followed:

- Design of earthworks so as to disturb as little acid sulfate soils as possible.
- Maintain acid sulfate soils in a saturated state prior to commencement of earthworks.
- Minimize disruption of the water table by emplacing sheet piles around deep excavations.
- Schedule earthworks so as to minimize the time that excavations are left open.
- Provide mechanisms to collect site run-off for neutralization treatment.
- Stockpile only small amounts of acid sulfate soils, and only as a short-term activity. Stockpiles should be up-gradient of the site so that run-off is dealt with on-site.
- Treat acid sulfate soils with alkaline stabilizing agents.
- Separate sulfides from soil material through mechanical hydraulic techniques (applicable only to coarse, non-cohesive soils such as sands and gravels). Sulfides must be disposed of appropriately.

- Excavate and rebury potential acid sulfate soils that are excavated from the site. Removed potential acid sulfate soils should remain saturated; reburial should be prompt and below the water table.

## RECOMMENDED AND CITED REFERENCES

Bradford, S.A. (2000). *The practical handbook of corrosion control in soils*. Canada: CASTI Publishing Inc.

Byerly, D.W. 1990. Guidelines for Handling Excavated Acid-Producing Materials. U.S. Department of Transportation, Report No. FHWA-FL-90-007.

De Arriba-Rodriguez, L., Villanueva-Balsera, J., Ortega-Fernandez, F., and Rodriguez-Perez, F. 2018. Methods to Evaluate Corrosion in Buried Steel Structures: A Review. *Metals*, Vol. 8., Iss. 5., 334.

Government of Western Australia, Department of Environment and Conservation. 2015a. Identification and Investigation of Acid Sulfate Soils and Acidic Landscapes. Part of the Acid Sulfate Soils Guideline Series. [https://www.der.wa.gov.au/images/documents/your-environment/acid-sulfate-soils/fact\\_sheets/Identification\\_and\\_investigation\\_of\\_acid\\_sulfate\\_soils\\_and\\_acidic\\_landscapes.pdf](https://www.der.wa.gov.au/images/documents/your-environment/acid-sulfate-soils/fact_sheets/Identification_and_investigation_of_acid_sulfate_soils_and_acidic_landscapes.pdf)

Government of Western Australia, Department of Environment and Conservation. 2015b. Treatment and Management of Soils and Water in Acid Sulfate Soil Landscapes. Part of the Acid Sulfate Soils Guideline Series. [https://www.der.wa.gov.au/images/documents/your-environment/acid-sulfate-soils/guidelines/Treatment\\_and\\_management\\_of\\_soil\\_and\\_water\\_in\\_acid\\_ss\\_landscapes.pdf](https://www.der.wa.gov.au/images/documents/your-environment/acid-sulfate-soils/guidelines/Treatment_and_management_of_soil_and_water_in_acid_ss_landscapes.pdf)

Reid, J. Murrey. 2012. "Chapter 37: Sulfate/acid soils". In *ICE Manual of Geotechnical Engineering, Volume 1 - Geotechnical Engineering Principles, Problematic Soils and Site Investigation*, John Burland, Tim Chapman, Hilary Skinner, and Michael Brown eds. London: ICE Publishing.

Testa, S.M., Jacobs, J.A., and Lehr, J.H. (Eds). 2014. *Acid Mine Drainage, Rock Drainage, and Acid Sulfate Soils: Causes, Assessment, Prediction, Prevention, and Remediation*. United Kingdom: Wiley.

United States Department of Transportation (USDOT). 1991. *Rock and Mineral Identification for Engineers*. U.S. Department of Transportation, Federal Highway Administration, Report No. FHWA-HI-91-025.

### 3.17 SULFIDE ROCK

#### THREATS POSED TO ENGINEERED WORKS

- Corrosion and degradation of metals and concrete by acid rock drainage (ARD)
- Staining of exposed rock and engineered faces by precipitation of iron oxides
- Environmental damage due to ARD

#### FIELD INDICATORS OF SULFIDE ROCK

- Iron staining on weathered rock
- Precipitated iron hydroxide (typically yellow in color) in drainage paths
- Lack of vegetation, stunted, or dead vegetation in drainage areas
- Sulfurous odors

#### MECHANISM OF SULFIDE ROCK ACIDIFICATION

When sulfide minerals in rock are exposed to oxygen in air or water they oxidize to form sulfuric acid. This chemical weathering process is most rapid in warm and wet environments. Acidic conditions can also mobilize iron, aluminum and toxic heavy metals from other minerals.

Oxidation is initiated by the exposure or fragmentation of sulfide-bearing rock, often through blasting, excavation or crushing. If planned works will not disturb a sulfide-bearing rock mass there is little threat of acidification, beyond the weathering of pyrite exposed on existing rock faces.

#### OCCURRENCE OF PYRITE IN ROCK

In most rock pyrite is the most abundant sulfide mineral. Pyrite occurs most often as small, disseminated grains that have a cubic shape, a pale brassy-yellow color (tarnishing to grey with exposure) and a metallic luster. Weathering of pyrite produces iron staining on rock faces. Procedures for the identification of pyrite in the field are detailed in *Rock and Mineral Identification for Engineers* (1991).

Pyrite is common in sedimentary rocks, especially those with high organic content (carbonaceous). Pyrite rarely occurs in significant abundance in igneous or metamorphic rocks except as a vein mineral, occurring in fractures and joints. Pyrite and other sulfide minerals are concentrated in metal-ore deposits and coal seams; this is why tailings dumps from such mines pose a threat of ARD (see Section 3.18).

The distribution of pyrite in a rock mass may be non-uniform. Outcrops or exposed faces may not be representative of the underlying or adjacent rock mass, and borings may be necessary to fully assess the pyrite content of a planned excavation.

## **SITE INVESTIGATION GOALS**

- a) Identify and characterize pyrite within the rock mass (through coring and visual inspection)
- b) Assess the concentration of pyrite in the rock mass and the potential for ARD (through sampling and laboratory testing)

## **SITE INVESTIGATION ACTIONS**

### **Coring and Visual Inspection**

Coring and visual inspection allows for characterization of the rock mass and pyrite within it. Cores should be taken from areas of planned rock disturbance; boring spacing depends largely upon the variability of rock beneath the site (both in terms of lithology and structure), boring depths should be at least to the maximum depth of planned works.

Pyrite in cores should be identified, and its distribution understood. Pyrite mineralization may be uniform throughout a rock mass or it may be correlated with the rock's internal structure; concentrating along seams, fractures or specific bedding planes.

Detailed boring logs should be maintained that document rock structure, lithology and pyrite occurrence. These logs can be used to delineate zones of pyrite occurrence in the rock mass and identify samples to be sent for laboratory analysis.

### **Sampling**

Samples should be obtained that represent the different zones of pyrite concentration identified in the boring logs. Rock core samples are necessary for thin-section compositional analysis, and cuttings are sufficient for visual compositional analysis and for acid-base accounting.

### **Laboratory Testing**

The aim of laboratory testing of pyrite-bearing rocks is to determine their composition, and assess the potential acidity created by the planned engineering works.

### ***Compositional Analysis***

The volume fraction of each mineral in the rock mass can be estimated by visual inspection of rock fragments, or by microscope analysis of thin-sections cut from samples.

### ***Potential Acidity***

Static methods:

Static methods are based upon the rock composition and disregard the particle shape and size. Only pyrite on exposed surfaces actually produces acid, static methods assume total degradation of all pyrite and are thus inherently conservative:

- Acid base Accounting (ABA) (ASTM E1915, AMIRA 2002)
- Net Acid Generation (NAG) (AMIRA, 2002)
- Saturated paste pH and electrical conductivity (AMIRA, 2002)

Kinetic methods:

Kinetic methods are based upon the observation of samples during simulated weathering processes, and generally take between 20 and 60 weeks to complete:

- Column Method (EPA Method 1627, AMIRA, 2002)
- Humidity Cell Method (ASTM D5744)

Each of these five methods is also presented briefly by EPA (1994).

## **Interpretation of Laboratory Results**

### ***Compositional Analysis***

Existing FHWA guidelines for sulfide rock management state that a rock visually estimated to contain a volume fraction of approximately 1 percent or more should be subjected to further analysis for ARD potential. This implies that rocks of less than 1 percent pyrite pose minimal threat of ARD.

### ***Potential Acidity***

Static methods:

For the ABA method, the composition of the rock is used to calculate the potential for acid production (by sulfides) and the potential for acid neutralization (mainly by carbonates and silicates). The difference between the two is the net neutralization potential:

$$\text{Net Neutralization Potential (NNP)} = \text{Neutralization Potential} - \text{Acid Potential}$$

Existing FHWA guidelines for sulfide rock management state that a net neutralization potential of -5 tons CaCO<sub>3</sub> or less, per 1000 tons of rock, is predictive of potential ARD (Byerly, 1990). However, it should be recognized that a rock of low NNP can still produce ARD if exposed in enough quantity.

For the NAG method, hydrogen peroxide is used to dissolve all the sulfides in a crushed sample. The pH of the solution is then measured and used to classify the tailings. A final pH value of less than 4.5 indicates potential for ARD. Further classifications exist beyond this initial division.

For the saturated paste pH and electrical conductivity method, distilled water is mixed with a crushed sample to form a paste. After equilibration, a paste pH value of less than 4 indicates potential for ARD.

Kinetic methods:

Kinetic Methods are designed to reflect the actual conditions to which the mine tailings will be subjected. The results from kinetic tests should be evaluated with respect to the level of weathering and acid generation deemed allowable during the construction and lifetime of the structure.

## **POSSIBLE MITIGATION OPTIONS**

- Avoid the use of pyritic rock for aggregate or facing material
- Avoid making excavations or cuts in pyritic rock
- Seal exposed faces of pyritic rock
- Neutralize ARD by channeling it through limestone drains
- Isolate pyritic aggregates with impermeable materials
- Design works in, or close to, sulfide rock to withstand acid corrosion

## **RECOMMENDED AND CITED REFERENCES**

AMIRA. 2002. ARD Test Handbook. Project P387A Prediction & Kinetic Control of Acid Mine Drainage. AMIRA international May 2002. Available from:  
<https://www.resolutionmineeis.us/documents/amira-2002>

Byerly, D.W. 1990. Guidelines for Handling Excavated Acid-Producing Materials. U.S. Department of Transportation, Report No. FHWA-FL-90-007

EPA. 1994. Technical Document: Acid Mine Drainage Prediction. US Environmental Protection Agency, document no: EPA530-R-94-036. Available from:  
<https://www.epa.gov/sites/production/files/2015-09/documents/amd.pdf>

Gusek, J.J., Bateman, V., Ozment, J., Oliver, L., Kathman, D., Waples, J., Rutkowski, T., Moore, H., Bowden, W., and Reither, A. 2011. Mitigating Impacts from Acid-Producing Rock in Tennessee Road Construction Projects. *In: Tailings and Mine Waste 2010. Proceedings from the 14<sup>th</sup> International Conference on Tailings and Mine Waste*, pp. 171-186.

Orndorff, Z.W. and Lee Daniels, W. 2002. Evaluation of Acid-Producing Sulfidic Materials in Virginia Highway Corridors. *Environmental Geology*, Vol. 49, No. 2, pp. 209-219.

Parbhakar-Fox, A., and Lottermoser, B.G. 2015. A Critical Review of Acid Rock Drainage Prediction Methods and Practices. *Minerals Engineering*, Vol. 82, 15, pp. 107-124.

Testa, S.M., Jacobs, J.A., and Lehr, J.H. (Eds). 2014. Acid Mine Drainage, Rock Drainage, and Acid Sulfate Soils: Causes, Assessment, Prediction, Prevention, and Remediation. United Kingdom: Wiley.

United States Department of Transportation (USDOT). 1991. Rock and Mineral Identification for Engineers. U.S. Department of Transportation, Federal Highway Administration, Report No. FHWA-HI-91-025.

### 3.18 SULFIDE MINE TAILINGS

#### THREATS POSED TO ENGINEERED WORKS

- Corrosion and degradation of metals and concrete by acid mine drainage (AMD)
- Staining of exposed faces by precipitation of iron oxides
- Environmental damage due to acid mine drainage (AMD)

#### FIELD IDENTIFICATION OF SULFIDE MINE TAILINGS

Mining activities in the U.S. are well documented and can be easily accessed through the National Mine Map Repository (NMMR), an online resource maintained by the Federal Office of Surface Mining (ORC). NMMR records include the locations of mine dumps. Sulfide mine tailings can be recognized in the field by some or all of the following indicators:

- Tailings dumps are often conical or tabular in shape with sides sloped at the material's angle of repose. Note that non-sulfide tailings dumps may also have this shape.
- Lack of vegetation on dumps, stunted or dead vegetation in drainage areas
- Iron staining and precipitated iron hydroxide (typically yellow in color) in drainage paths
- Sulfurous odors

#### MECHANISM OF SULFIDE MINE TAILINGS ACIDIFICATION

Tailings from metal or coal mines are very often rich in metal sulfides. When sulfide minerals are exposed to oxygen in air or water they oxidize to form sulfuric acid. This chemical weathering process is more rapid in warmer and wetter environments. Acidic conditions can also mobilize iron, aluminum and toxic heavy metals from other minerals.

Sulfide mine tailings pose a threat to construction works when existing at, or upstream of, locations of planned development, or when incorporated as fill material.

#### SITE INVESTIGATION GOALS

- a) Research the mining history of the site and obtain information on the tailings dump (through a preliminary information review)
- b) Assess the existing and potential acidity of the mine tailings (through sampling, field testing and laboratory testing)

#### SITE INVESTIGATION ACTIONS

##### Preliminary Information Review

Information on mines can be found at the NMMR (described above). More detailed information may be available directly from the mining company. Useful information includes:

- Type of mine



- Volume of the tailings dump
- Composition, chemistry and grain size of the tailings

## **Borings**

The purpose of borings in mine tailings is to obtain samples for laboratory analysis. Due to variability in the mined material, a tailings dump may be heterogeneous both laterally and vertically. Borings should be spaced to characterize the entire tailings deposit, and penetrate its entire depth.

## **Sampling**

As well as spatial heterogeneity reflecting changes in mined material, sulfide mine tailings (particularly those dumped some time ago) may have developed vertical zonation of mineralogy or chemistry. Samples should be taken at regular depth intervals, disturbed samples are sufficient for chemical analysis.

## **Field Testing**

Field testing of mine tailings serves to establish if oxidizable sulfides are present, and to assess the acidity of the tailings run-off. A pH peroxide test ( $\text{pH}_{\text{FOX}}$ ) can be conducted on tailings in the field to qualitatively assess the presence of oxidizable sulfides. A portable electronic potentiometer can be used to determine the pH of tailings run-off; a pH of less than 4.5 is considered to be acidic.

## **Laboratory Testing**

The aim of laboratory testing of sulfide mine tailings is to assess their potential acidity.

Static methods (based upon compositional analysis):

- Acid base Accounting (ABA) (ASTM E1915, AMIRA, 2002)
- Net Acid Generation (NAG) (AMIRA, 2002)
- Saturated paste pH and electrical conductivity (AMIRA, 2002)

Kinetic methods (based upon the observation during simulated weathering processes):

- Column Method (EPA Method 1627, AMIRA, 2002)
- Humidity Cell Method (ASTM D5744)

Each of these five methods is also presented briefly by EPA (1994).

## **Interpretation of Laboratory Results**

Static methods:

For the ABA method, the composition of the tailings is used to calculate the potential for acid production (by sulfides) and the potential for neutralization of that acid by other chemical components of the tailings (mainly by carbonates and silicates). The net neutralization potential is the difference between the two, and indicates the quantity of un-neutralized acid that might be produced for a given volume of tailings material:

$$\text{Net Neutralization Potential (NNP)} = \text{Neutralization Potential} - \text{Acid Potential}$$

Existing FHWA guidelines for sulfide rock management state that a NNP value of -5 tons CaCO<sub>3</sub> or less, per 1000 tons of rock, is predictive of potential acid drainage (Byerly, 1990). However, it should be recognized that tailings of low NNP can still produce acid mine drainage if exposed in enough quantity.

For the NAG method, hydrogen peroxide is used to dissolve all the sulfides in the crushed sample. The pH of the solution is then measured and used to classify the tailings. A final pH value of less than 4.5 indicates that the tailings are potentially acid-generating. Further classifications exist beyond this initial division.

For the saturated paste pH and electrical conductivity method, distilled water is mixed with a crushed sample to form a paste, which is given time to equilibrate. A paste pH value of less than 4 indicates that the tailings are acid-generating.

Kinetic methods:

Kinetic experiments are designed to reflect the actual conditions to which the mine tailings will be subjected. The results from kinetic tests should be evaluated with respect to the level of weathering and acid generation deemed allowable during the construction and lifetime of the structure.

## **POSSIBLE MITIGATION OPTIONS**

- Avoidance
- Direct tailings run-off away from engineering works
- Tailings that exhibit any potential for acidity should not be incorporated as fill material
- Concrete or metal structures emplaced within, or close to, potentially acidic tailings should be designed to withstand corrosive conditions
- If potentially acidic tailings are unavoidably incorporated into a site they should be isolated from water through-flow (to prevent weathering and the release of leachate)

## **RECOMMENDED AND CITED REFERENCES**

AMIRA. 2002. ARD Test Handbook. Project P387A Prediction & Kinetic Control of Acid Mine Drainage. AMIRA international May 2002. Available from: <https://www.resolutionmineeis.us/documents/amira-2002>

Byerly, D.W. 1990. Guidelines for Handling Excavated Acid-Producing Materials. U.S. Department of Transportation, Report No. FHWA-FL-90-007

Collins, R.J. and Miller, R.H. 1976. Availability of Mining Wastes and their Potential for Use as Highway Material. U.S. Department of Transportation, Report No. FHWA-RD-76-106.

Colorado Division of Minerals and Geology. 2002. Best Practices in Abandoned Mine Land Reclamation: the remediation of past mining activities. State of Colorado, Department of Natural Resources. [electronic document]. Available from: [http://cusp.ws/wp-content/uploads/2014/05/CO\\_DMG\\_BMPs\\_AML\\_Reclamation.pdf](http://cusp.ws/wp-content/uploads/2014/05/CO_DMG_BMPs_AML_Reclamation.pdf)

EPA. 1994. Technical Document: Acid Mine Drainage Prediction. US Environmental Protection Agency, document no: EPA530-R-94-036. Available from: <https://www.epa.gov/sites/production/files/2015-09/documents/amd.pdf>

Lottermoser, B. 2003. Sulfidic Mine Wastes. *In* Mine Wastes (Chapter 2). Springer-Verlag.

Testa, S.M., Jacobs, J.A., and Lehr, J.H. (Eds). 2014. Acid Mine Drainage, Rock Drainage, and Acid Sulfate Soils: Causes, Assessment, Prediction, Prevention, and Remediation. United Kingdom: Wiley.

United States Department of Transportation (USDOT). 1997. User Guidelines for Waste and Byproduct Materials in Pavement Construction. U.S. Department of Transportation, Report No. FHWA-RD-97-148.

United States Department of the Interior, Office of Surface Mining Reclamation and Enforcement. National Mine Map Repository (NMMR). Available from: <https://mmr.osmre.gov/>.

Vick, S.G. 1996. Hydraulic Tailings. *In* Landslides: Investigation and Mitigation (Chapter 22). Transportation Research Board, Special Report 247. National Research Council.

### 3.19 UNSTABLE ROCK SLOPES

#### THREATS POSED TO ENGINEERED WORKS

- Damage to structures caused by falling rock
- Blockage of transportation routes by rock debris

#### FIELD INDICATORS OF UNSTABLE ROCK SLOPES

Recent movements:

- Rock debris, as isolated blocks or accumulations of talus, on the slope or at its base
- Fresh rock faces (scars) on outcrops
- Disturbed or broken vegetation

Potentially unstable slopes:

- Highly fractured and/or jointed rock mass on steep slope
- Discontinuities in the rock mass that daylight in the slope
- Undercutting of rock mass by differential weathering, producing overhangs
- Vertical columns or sheets of rock that are separated from the rock mass and may topple
- Tension cracks paralleling the crest of slopes
- Ice buildup in joints and fractures, indicating likely freeze-thaw action

#### PRIMARY ELEMENTS CONTROLLING ROCK SLOPE FAILURE

Higgins and Andrew (2012) have identified two primary elements that control the failure of rock slopes; material characteristics and slope characteristics.

##### Material Characteristics

A strong and homogeneous rock mass may form stable, high and steep slopes. However, this is quite rare. Most rock masses contain discontinuities or zones of weakness that will allow deformation or movement, and create the potential for rockfall under certain conditions.

Discontinuities are usually naturally occurring structural defects, such as joints, bedding planes, foliations, fractures and faults. Discontinuities may also be caused by construction activities, particularly blasting. Discontinuities form discrete blocks of rock, the stability of which is largely (but not solely) controlled by the orientation of discontinuities with relation to the slope face.

Zones or planes of weakness may develop in places where the rock mass has experienced more advanced weathering or alteration. They may also be defined by weaker rock-types within the rock mass, such as interbedded shale or mudstone.

## **Slope Characteristics**

In order for a rock to detach from a slope, the slope face must be steep enough to expose the potential failure surfaces. The geometrical relationships between the slope and the failure surfaces are an indicator of the potential types of failure that may occur. The shear strength of potential failure surfaces must be overcome in order for movement to initiate.

Once detachment has occurred, moving rock blocks can only continue as far down-slope as their kinetic energy and travel paths allow. Gravity is the primary driver of rockfall motion, but slope breaks and obstacles can arrest rock movement before the moving block has reached the bottom of the slope.

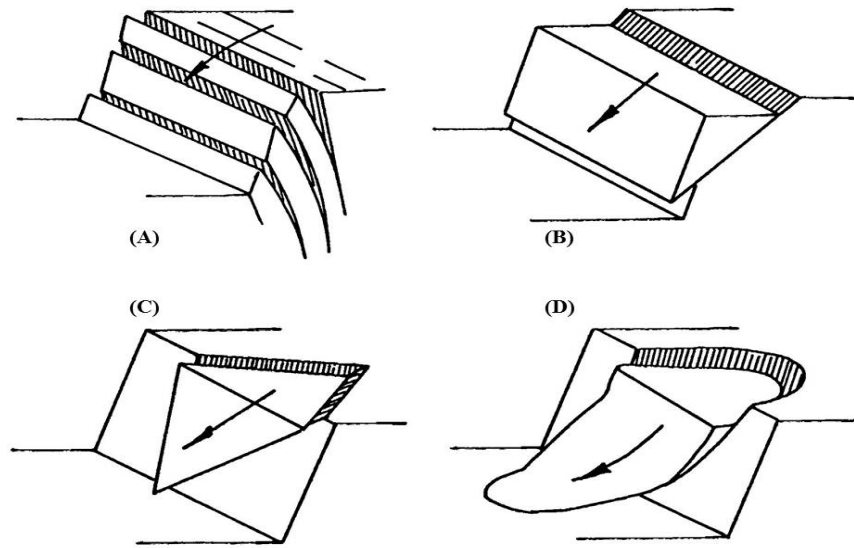
## **TYPES OF ROCK SLOPE FAILURES**

Failures on rock slopes may result in rockfall or rockslide. Rockfall describes the movement of a discrete rock block, or multiple blocks, downslope. Rockslide describes the more large-scale failure of a rock mass, resulting in the downslope movement of a significant portion of a slope or cut. Rockslides are more likely to occur in rock masses that contain a persistent discontinuity, or set of discontinuities, thus enabling the failure of large volume of the rock mass in a single event. Turner and Schuster (2012) have classified rockfall failures as ‘simple structurally-controlled’, ‘complex structurally-controlled’ and ‘environmentally-controlled’.

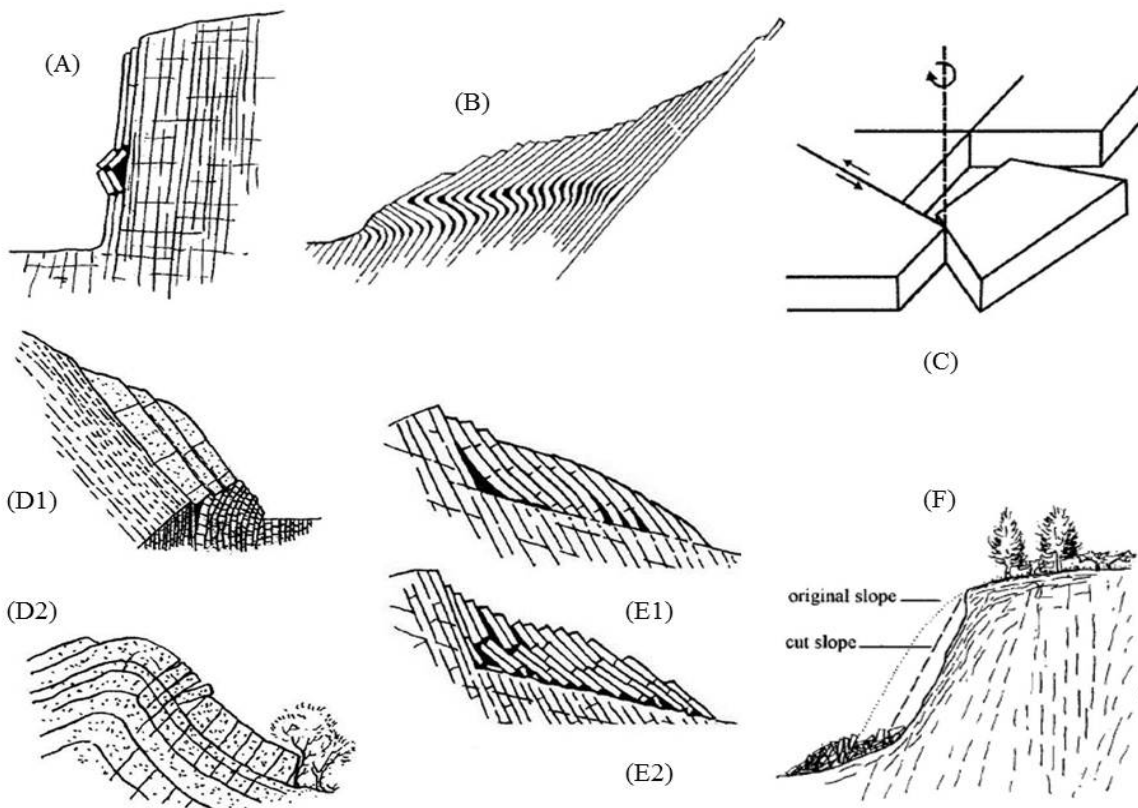
Simple structurally-controlled failures, illustrated in Figure 3-29, include planar, wedge, toppling and circular sliding. These forms of failure are relatively easy to identify using stereographic techniques. Planar, wedge and toppling failures are controlled by discontinuities. Circular failures typically occur in either highly fractured rock with no identifiable discontinuity pattern, or across discontinuities in weak materials.

Complex structurally-controlled failures, illustrated in Figure 3-30, include buckling and kink-band slumping, block torsion, rock slump, sheet failure, bilinear wedge failure, key-block failure, and secondary toppling. While these failures are structurally controlled, they often occur where slope and discontinuity geometries are more complex than those contributing to simple structurally-controlled failures.

Environmentally controlled failures, illustrated in Figure 3-31, include differential erosion and weathering, boulder fall, and raveling. These processes cause rockfall on a variety of scales. For more detailed descriptions of rock slope failure modes, see Higgins and Andrew (2012).

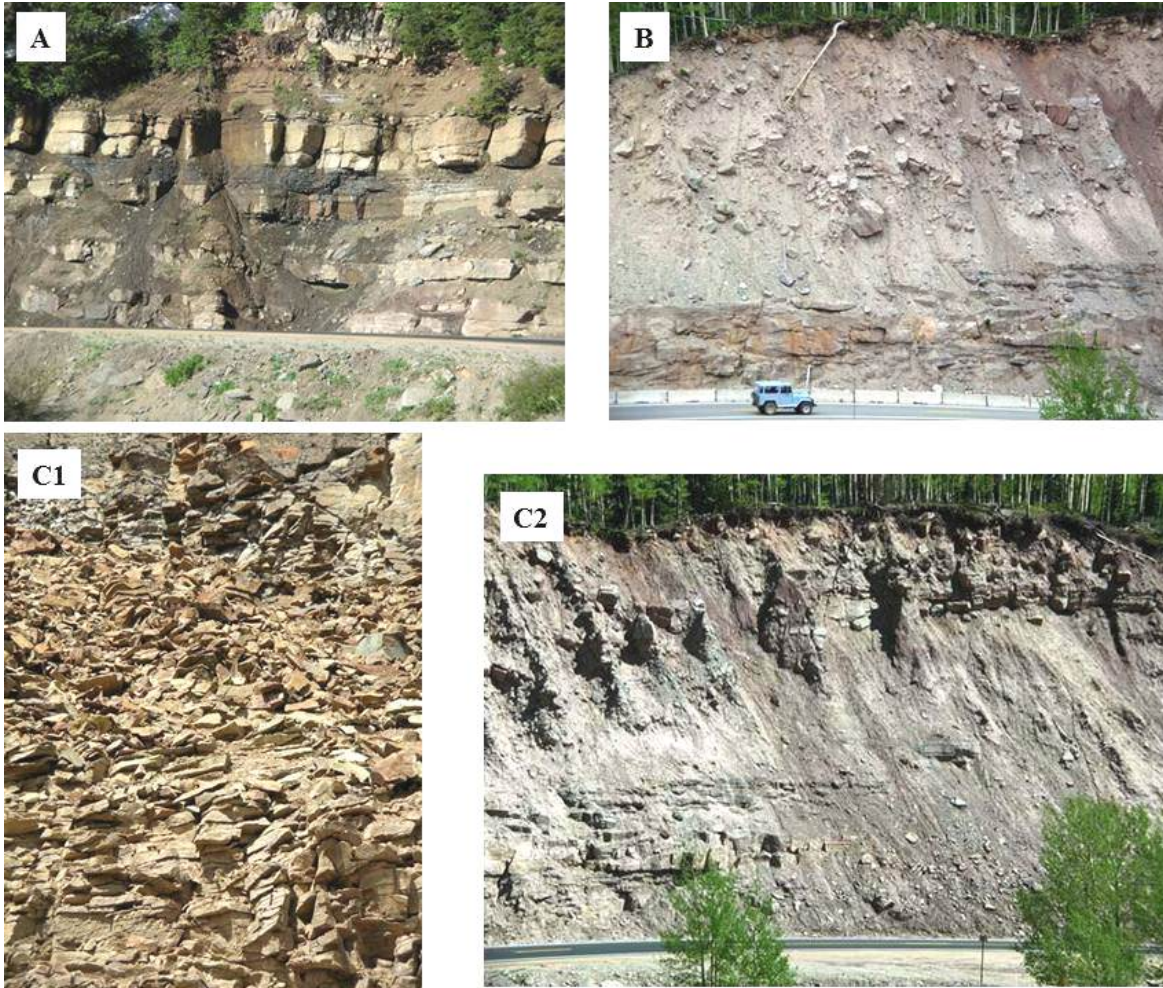


**Figure 3-29** Simple structurally-controlled failures of rock slopes: (A) toppling failure, (B) planar failure, (C) wedge failure and (D) circular failure. From Wyllie and Mah (2004).



**Figure 3-30** Complex structurally-controlled failures of rock slopes: (A) buckling; (B) kink band slumping; (C) block torsion; (D1) secondary toppling – toe toppling; (D2) secondary toppling – head toppling; (E1 and E2) rock slumping; (F) sheet failure. From Goodman and Kieffer (2000).





**Figure 3-31** Environmentally-controlled failures of rock slopes: (A) differential weathering of interbedded shales and sandstones, creating sandstone rockfall blocks; (B) boulder fall from colluvial soils; (C1) raveling of thinly-bedded and highly-fractured sedimentary rock; (C2) raveling of a road cut in highly-weathered sedimentary rock. Photographs courtesy of J.D. Higgins, Colorado School of Mines.

### **FACTORS INFLUENCING THE STABILITY OF ROCK SLOPES**

- Height of slope (tall slopes contain a greater mass of material)
- Angle of slope (on steep slopes the direction of potential mass movement is along the line of action of the material weight)
- Discontinuity orientation and spacing
- Discontinuity condition (waviness, roughness, aperture, wall strength, infilling material)
- Groundwater level (hydrostatic pressure reduces effective stress and shear strength)
- Groundwater movement (flow of groundwater out of a slope creates a seepage force)
- Material properties (shear strength of intact rock, and of discontinuities)
- Uniformity of material properties (adverse strata, zones of more advanced weathering)

## **POTENTIAL TRIGGERS OF MOVEMENT ON ROCK SLOPES**

- Rainfall events or snowmelt – increase hydrostatic pressure and seepage forces; decrease shear strength of discontinuities and clay-rich materials; erode fine materials to dislodge loose blocks
- Freeze-thaw action and root action - create pressure in and propagate discontinuities
- Weathering - reduces intact rock strength; causes undercutting; produces alteration products in discontinuities that may reduce their shear strength
- Erosion or raveling – removes support
- Removal of slope toe – removes lateral support
- Over-steepening of slope – increases driving forces; causes discontinuities to daylight
- Loading of slope – increases shear stress
- Ground shaking from earthquakes, blasting or other construction activities – increases driving forces

## **SITE INVESTIGATION GOALS**

The following site investigation guidelines have been adapted and condensed largely from Andrew and Higgins (2012) and Wyllie and Mah (2004).

- a) Gather records of past rockfall events (through review of existing information)
- b) Understand surface geology, and preliminarily identify unstable and potentially unstable rock slopes (through the study of geologic maps and aerial photographs, including Google Earth, or other internet or printed aerial photos, and reconnaissance mapping)
- c) Monitor potential locations of slope movement (through installation of monitoring equipment)
- d) Characterize the geometry of the rock mass (through geologic mapping, geophysics and borings)
- e) Assign rock mass classification
- f) Measure rock strength properties (through field or laboratory measurement)
- g) Understand groundwater conditions within the slope (through field reconnaissance and/or the installation of wells or piezometers)
- h) Create slope profiles (through surveying, GPS or topographic methods)

## **SITE INVESTIGATION ACTIONS**

### **Review of Existing Information**

The review of existing information is directed at previous rockfall and rockslide events. If the rock slope is close to existing transportation routes, past rockfall events are likely to be documented by local transportation agencies and law enforcement. In the case of the former, useful information is likely to be held by maintenance departments. Of interest are the frequency, location and character of rockfall events, as well as their timing with relation to weather and the seasons. This information may indicate the rockfall mechanism(s) at work, and possible triggers.



## **Geologic Maps**

The general geology of the site can be established from geologic maps. Of interest are rock types and information of structural features such as bedding planes, joints, and faults. Rock type greatly influences rock-mass properties, some rock types are associated with characteristic structural and mechanical properties.

## **Aerial Photographs and Reconnaissance Mapping**

Aerial photographs, both stereo-pairs and oblique, in addition to Google Earth and other internet or printed aerial images, are useful in identifying field indicators of unstable or potentially unstable slopes (listed above). The size, frequency and style of slope movements can be estimated, and possible source zones, travel paths and run-out zones identified. Aerial photographs and other associated resources can be used to plan reconnaissance mapping operations, but are of limited use in heavily vegetated areas.

Reconnaissance mapping of rock slopes aims to identify recent slope movements, to recognize potentially unstable slope conditions, and to preliminarily investigate the geology and the groundwater conditions of the site. Indicators of recent slope movements, and potentially unstable slope conditions (listed above) should be recognized. The lithology, general structural pattern, and degree of weathering seen in outcrops may indicate potential types of rockfall failure. The groundwater level within the rock mass may be indicated by seepage from discontinuities. Groundwater levels are likely to fluctuate; seepage stains indicate that the groundwater level has been higher than at the time of the site visit.

## **Slope Monitoring Equipment**

Monitoring of potentially unstable rock slopes provides quantitative data of current movements. This information is of great use in safeguarding persons or installations that may be affected, in planning and assessment of mitigation efforts and slope design, and in providing geotechnical information regarding slope failure mechanisms.

It is recommended that personnel experienced in applied geology and the behavior of rock slopes be involved in identifying locations for monitoring equipment. The sooner monitoring equipment is installed, the sooner useful data can be made available. Some parameters of interest, and instrumentation that may be used to monitor them, are listed in Table 3-11.

**Table 3-11** Some parameters of interest when investigating current movements on rock slopes, and the instrumentation that may be used to monitor them.

Parameter of Interest	Instrumentation
Horizontal or vertical displacement of reference points	Survey points; total stations with electronic distance meters (EDM); Differential Global Positioning System (DGPS)
Widening or narrowing of fractures	Crack meter; extensometer; strain gauge
Surface tilting or block rotation	Tiltmeter
Overall slope geometry change detection	Scanning radar system; repeat point clouds generated using Structure from Motion photogrammetry or LiDAR scans (Light Detection and Ranging)
Groundwater level and pore pressure	Piezometer
Rainfall	Rain gauge

## Geologic Mapping

Geologic mapping of rock slopes aims primarily to characterize geometry of the rock mass, by compiling detailed and systematic information of:

- Lithology
- Discontinuities
  - Orientation
  - Spacing
  - Possible block sizes
  - Persistence
  - Waviness and roughness
  - Wall condition and strength
  - Aperture
  - Infilling material
- Degree of weathering
- Seepage

Data from geologic mapping is used in kinematic analysis and for classification of the rock mass. Standard geologic mapping methods include scanline surveying and window mapping. These methods, and the application of the data retrieved, are described in Wyllie and Mah (2004).

If surface exposures are limited, or subsurface conditions are believed to differ from those at the surface, core-boring may be necessary to supplement surface mapping data. In circumstances where it is not possible to directly access an exposure, possibly because of difficult access or

dangerous conditions, terrestrial photogrammetry or LiDAR scans can be used to map rock structure (Wyllie and Mah, 2004).

## **Geophysics and Borings**

Subsurface investigations may not be necessary. They should be conducted where:

- Surface exposures are limited, or
- Important discontinuities may exist in the rock mass that do not daylight in exposures, or
- Engineering properties of the rock within the slope may vary considerably from those at the surface.

Geophysical methods are useful in the preliminary stages of site investigation to provide such information as:

- Depth of weathering
- Bedrock profile and contacts between rock types of significantly different density
- Location of major faults
- Degree of fracturing of the rock.

The results of geophysical investigation are usually not sufficiently accurate to be used in final design, and should preferably be calibrated by comparison with boring data. Geophysical surveys can then be used to extend boring data. For rock-slope engineering purposes, seismic refraction is the most commonly used geophysical technique (Wyllie and Mah, 2004).

Borings should be used to supplement surface mapping. The extent of drilling and coring operations depends upon the amount of required data. Coring provides samples for laboratory analysis, and such information as:

- In-situ rock strength
- Fracture frequency
- Shear zone characteristics
- Locations of discontinuities
- Orientation of discontinuities (if oriented core is retrieved)

## **Rock Mass Classification**

It is common practice to use standard rock mass classification schemes to compare the engineering quality of rock masses. Commonly-used classification schemes include:

- Rock Quality Designation (RQD) (Deere et al, 1967; Deere and Deere, 1989)
  - ASTM D6032
  - Requires measurement of recovered rock cores
  - Used as a component in RMR and Q classifications
- Rock Mass Rating (RMR) (Bieniawski, 1989)
  - Provides guidelines for necessary support

- Applies to a variety of engineering applications
- Requires rock strength, RQD, discontinuity spacing, condition and orientation, groundwater conditions
- NGI-Q Rating (Barton, 1974; NGI, 2015)
  - Originally developed for tunnel support design
  - Modified for applications to rockfall (Harp and Noble, 1993)
  - Requires joint roughness, alteration, water presence and aperture
- Geological Strength Index (GSI) (Hoek and Brown, 2019)
  - Provides data for numerical modeling of slope design, tunneling or foundations
  - Requires rock discontinuity character, surface conditions and weathering state

## **Rock Strength Properties**

After internal structure and geometry, the most important factor governing rock slope stability is the shear strength parameters (cohesion and angle of internal friction) of potential failure surfaces. The likely style of slope failure has a large bearing on the strength parameters that should be used in stability assessments:

- In rock without discontinuities or zones of weakness, where failure must occur through intact rock, the strength parameters of the intact rock should be used to characterize the rock mass.
- In rock containing persistent, through-going discontinuities or beds of weak material, where failure is most likely to occur along these discontinuities or weak beds, the strength parameters of the discontinuities or weak beds should be used to characterize the rock mass.
- In rock containing non-persistent discontinuities, where failure is likely to occur along discontinuities and through intact rock, a combination of the strength parameters of the discontinuities and intact rock should be used to characterize the rock mass.
- In some cases, it may be possible to use back-analysis of past failures to calculate the strength parameters of a rock slope. This technique may be useful when dealing with failure through variable materials, such as highly weathered soil/rock profiles.

The procedures for calculating or assessing shear strength parameters of discontinuities, intact rock, or the rock-mass as a whole are described by Wyllie and Mah (2004). They may involve a combination of field observations and empirical correlation, the use of field or laboratory testing, or back-analysis.

## **Groundwater Conditions**

Water within a rock slope may have considerable influence on slope stability. Water may reduce the cohesion and shear strength of fractures and infilling materials, and produce expansive forces in clays or from the formation of ice. Water within fractures (especially those with low persistence, within which water can accumulate) produces an internal pressure that may reduce stability. Faults or fractures filled with low-conductivity infilling such as clay or fault gouge may act as groundwater barriers behind which water pressures may develop. Clean fractures

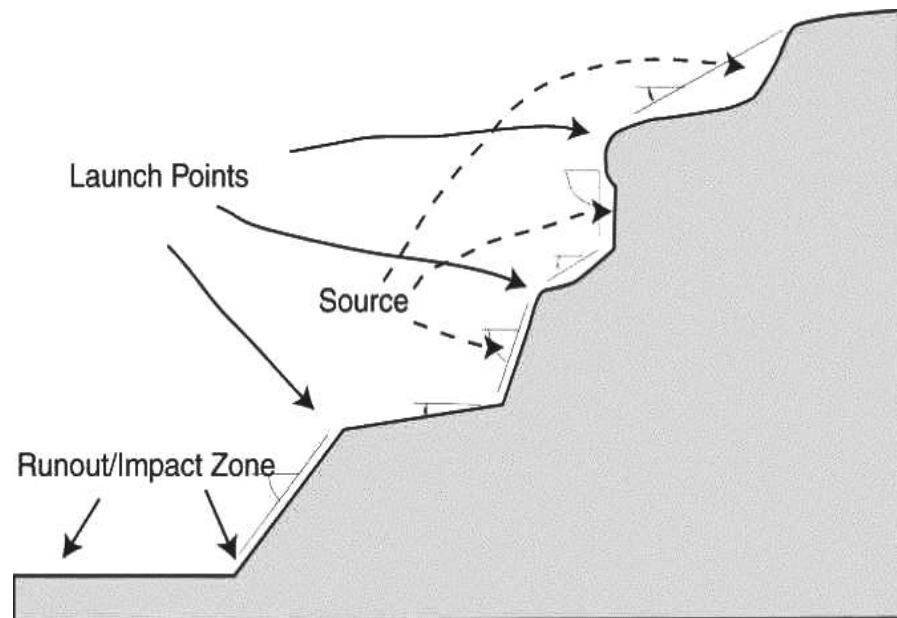
with some aperture, or faults filled with clean broken rock may act as drains that reduce water pressures in the slope.

It is important to measure groundwater levels and their fluctuations, in order to calculate water pressures to be used in stability calculations. This can be done by installing piezometers at relevant locations. Guidelines for ground water pressure measurement are given by Wyllie and Mah (2004).

If it is necessary to estimate groundwater discharge, or to design drainage systems, it is important to measure the hydraulic conductivity of the rock mass. This can be done in the field with variable head tests or pumping tests, guidelines for which are given by Wyllie and Mah (2004).

### Slope Profiling

The modeling of rockfall or rockslide behavior, and the design of mitigation, requires the profiling of the rock slope. Cross sections and a contour map should be developed through conventional surveying, GPS or existing topographic data. Factors affecting the downslope movement of loose rock should be accurately portrayed including slope height, slope angle, gullies, outcrops, ledges, rock type variations, soil cover and vegetative cover. Potential source, launch, impact and runout zones of rock debris should be identified. An example of a slope profile is shown in Figure 3-32. LiDAR mapping may also be useful for 3-dimensional modeling programs.



**Figure 3-32.** Slope profile identifying possible source, launch, impact and run-out zones. Modified from Branwer (1994).

## POSSIBLE MITIGATION OPTIONS

### Avoidance:

- Alternate route selection
- Bridging

### Stabilization:

- Removal of unstable rock (scaling, blasting, chemical expanders)
- Reduction of slope angle
- Drainage to reduce pore water pressure (above the slope, and from within)
- Support systems (rock bolts, dowels, buttresses, shotcrete, etc.)

### Protection:

- Draped Mesh
- Diversion mounds or berms
- Catchment ditches
- Rock fences and nets
- Rock barriers and walls
- Rock sheds and tunnels

## RECOMMENDED AND CITED REFERENCES

Andrew, R. and Higgins, J.D. 2012. Site Characterization. *In* Rockfall Characterization and Control (Turner, A.K. and Schuster, R.L. eds.), Transportation Research Board, National Academies.

Barton, N.R., Lien, R. and Lunde, J. 1974. Engineering Classification of Rock Masses for The Design of Tunnel Support. *Rock Mechanics*. Vol.6, No.4, pp. 189-236.

Bieniawski, Z.T. 1989. Engineering Rock Mass Classifications. Wiley. New York.

Branwer, C.O. 1994. Rockfall Hazard Mitigation Methods. National Highway Institute, Course No. 13219. U.S. Department of Transportation, Report No. FHWA SA-93-085.

Deere, D.U. and Deere, D.W. 1989. Rock Quality Designation (RQD) After Twenty Years. U.S. Army Corps of Engineers (USACE), Report GL-89-1.

Deere, D.U., Hendron, A.J., Patton, F.D. and Cording, E.J. 1967. Design of Surface and Near-Surface Construction in Rock. *In* Failure and Breakage of Rock, Proceedings of the 8th U.S. Symposium on Rock Mechanics. (C. Fairhurst, Ed.). pp. 237-302. Society of Mining Engineers, American Institute of Mining, Metallurgical and Petroleum Engineers. New York.

Goodman, R.E. and Kieffer, S.D. 2000. Behavior of Rock in Slopes. *Journal of Geoenvironmental Engineering*, Vol. 126, No. 8, pp. 675-684.

Harp, E.L. and Noble, M.A. 1993. An Engineering Rock Classification to Evaluate Seismic Rockfall Susceptibility and Its Application to the Wasatch Front. *Bulletin of the Association of Engineering Geologists*, Vol. XXX, No. 3, pp. 239-319.

Higgins, J.D. and Andrew, R. 2012. Rockfall Types and Causes. *In Rockfall Characterization and Control* (Turner, A.K. and Schuster, R.L. eds.), Transportation Research Board, National Academies.

Highland, Lynn M. 2008. The Landslide Handbook – A Guide to Understanding Landslides. *US Department of the Interior, US Geological Survey, Circular 1325*. Available from: <https://pubs.usgs.gov/circ/1325/>

Hoek, E. and Brown, E.T. 2019. The Hoek-Brown failure criterion and GSI – 2018 edition. *Journal of Rock Mechanics and Geotechnical Engineering*, Vol. 11, No. 3, pp. 445-463.

NGI. 2015. Using the Q-system: Rock mass classification and support design. Oslo: Norwegian Geotechnical Institute, 56 p, [electronic document]. Available from: <https://www.ngi.no/eng/Services/Technical-expertise/Engineering-geology-and-rock-mechanics/Q-system>

Turner, A.K. and Schuster, R.L. (Eds). 2012. *Rockfall Characterization and Control*. Transportation Research Board, National Academies.

Wyllie, D.C and Mah, C.W. 2004. *Rock Slope Engineering: Civil and Mining* (4<sup>th</sup> Ed.). Spon Press, New York.

Wyllie, D.C. 2017. *Rock Slope Engineering: Civil Applications* (5<sup>th</sup> Ed.). CRC Press, Taylor & Francis Group.

## 3.20 UNSTABLE SOIL SLOPES

### THREATS POSED TO ENGINEERED WORKS

- Damage to structures on slopes due to differential movement
- Disruption of transportation and drainage routes
- Burial of installations below slopes

### FIELD INDICATORS OF UNSTABLE SOIL SLOPES

The most indicative sign that a slope is unstable is evidence of previous slope movements. The features produced by slope movements are numerous and varied, depending on the type of movement, the type of the soil material, the regional climate and the time since the movement occurred. Figures 3-33 and 3-34 may help to identify past slope movements in the field. Features that may indicate movement has occurred on a slope include:

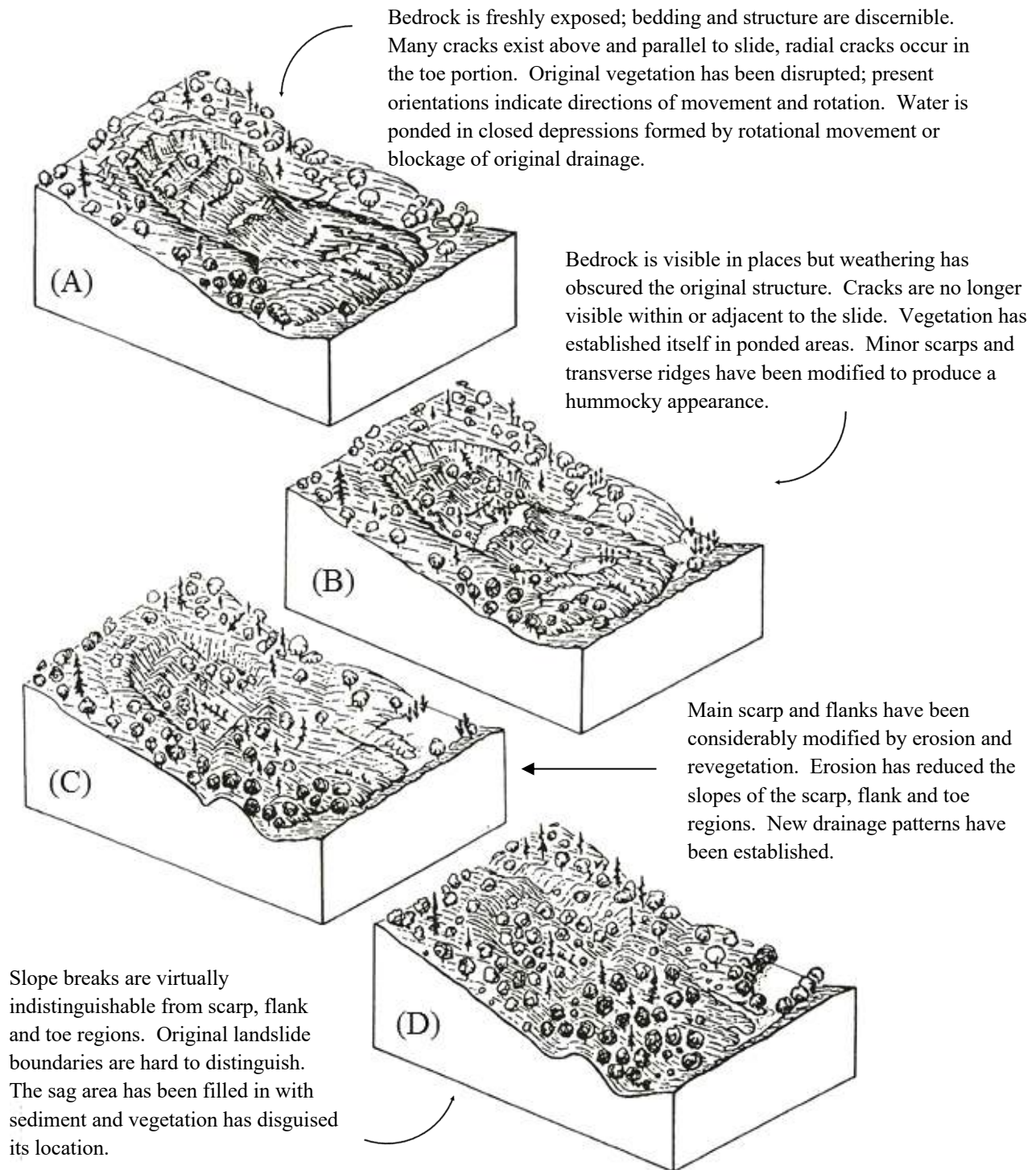
#### Active Instability or Recent Movement:

- Hummocky ground
- Ponded water and/or areas of richer vegetation
- Scarps and areas of soil depletion
- Tension cracks or fissures
- Disrupted lineaments such as fences, guardrails and drainage ditches
- Tilting of trees, fence posts or telephone poles. Given enough time a tilted tree will grow vertical again, producing a crooked or curved trunk. This may be an indicator of a relatively old slope movement, although it can also occur from repeated snow loading

#### Potential Instability:

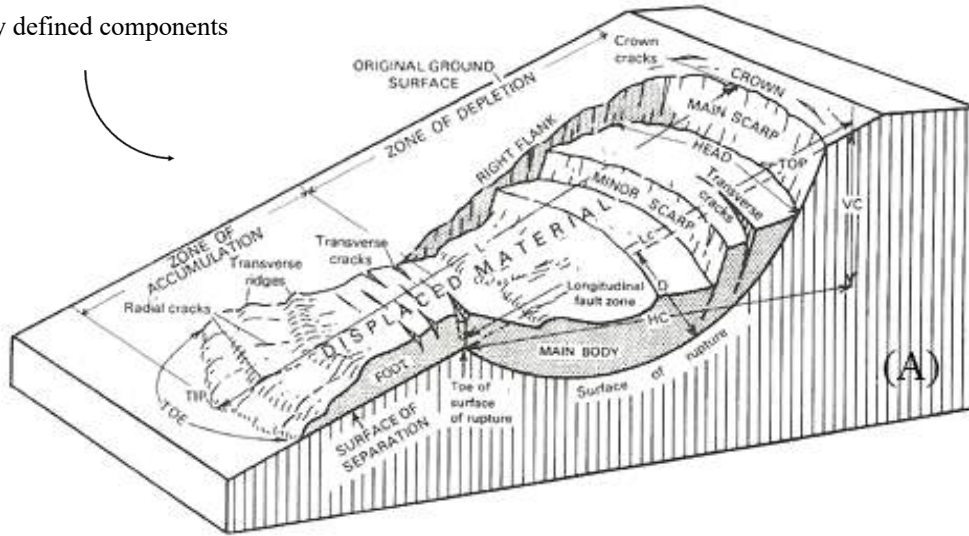
- Slopes containing both weak and competent soil layers
- Slopes that may suffer erosion at their base, possibly from rivers or flash floods
- Slopes containing springs or seeps, often indicated by more developed vegetation
- Previously vegetated slopes from which vegetation has been cleared, possibly by deforestation or fire.
- Steep slopes consisting of weak materials



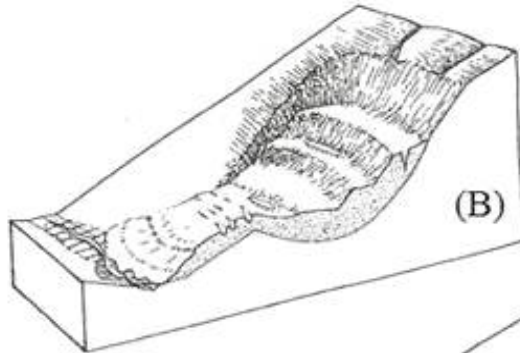


**Figure 3-33** Block diagrams of morphologic changes with time of an idealized rotational slide in a humid climate that may help to identify past slope movements, especially when combined with observations from site reconnaissance and aerial photography. (A) Recently active, (B) dormant young, (C) dormant mature and (D) dormant old. Modified from McCalpin (1984).

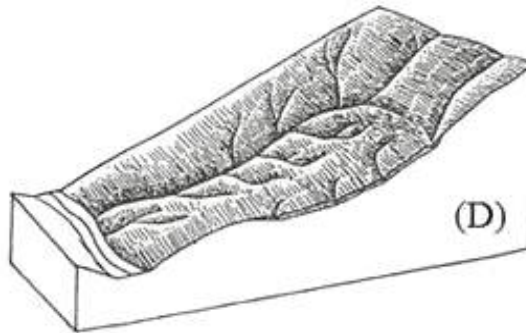
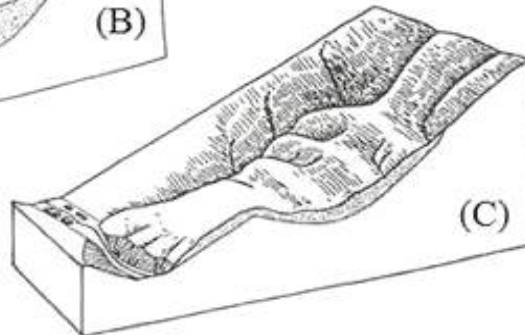
Sharply defined components



Slope wash and shallow mass movements modify sharp edges, but drainage lines are not yet established.



Drainage follows rifts and sags on slide mass, internal blocks are slightly dissected, material is eroded from slide mass.



Slide mass is almost completely removed, drainage network shows weak structural control, valley drainage has reestablished its pre-slide profile.

**Figure 3-34** Block diagrams of morphologic changes with time of an idealized rotational slide in an arid or semi-arid climate that may help to identify past slope movements, especially when combined with observations from site reconnaissance and aerial photography. (A) recently active, (B) dormant young, (C) dormant mature and (D) dormant old. Modified from Varnes (1978, block A) and McCaipin (1984, blocks B-D).

## CLASSIFICATION OF MOVEMENTS ON SOIL SLOPES

The classification system used by the Transportation Research Board (TRB) is adopted from Varnes (1978). Slope Movements are first categorized according to the material involved and the type of movement, as shown in Table 3-12. Movements can then be further described in terms of the state, distribution and style of their activity, their rate and their water content, as shown in Table 3-13. The descriptive terms should be placed in front of the classification terms, an example might be:

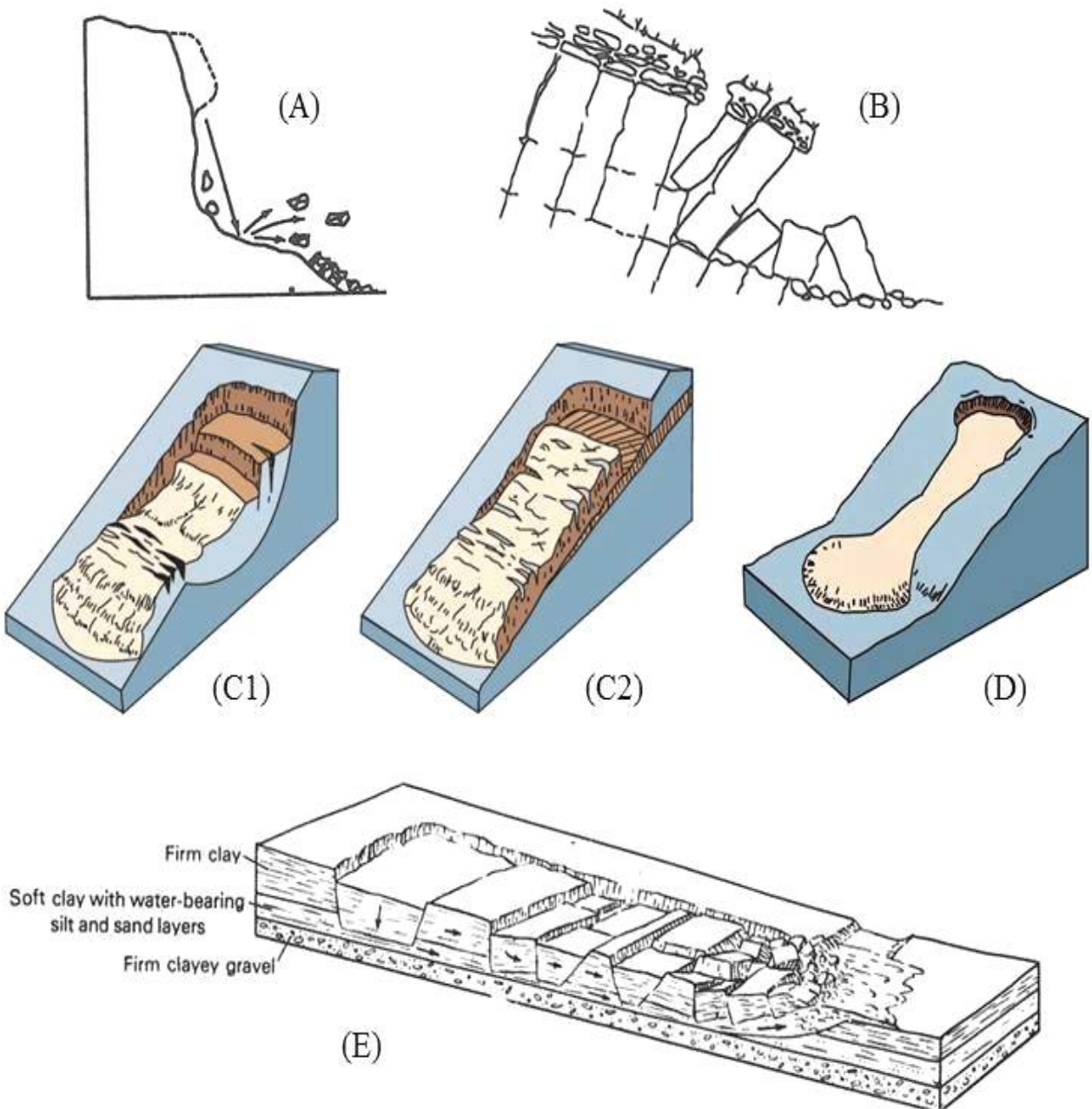
“The movement is an active, advancing, complex, rapid, dry, earth slide”

**Table 3-12** Abbreviated classification of slope movements. From Cruden and Varnes (1996). The types of movement listed in Table 3-13 are illustrated schematically in Figure 3-35

Type of Movement	Type of Material		
	Bedrock	Engineering Soils	
		Predominantly Coarse	Predominantly Fine
Fall	Rock fall	Debris fall	Earth fall
Topple	Rock topple	Debris topple	Earth topple
Slide	Rock slide	Debris slide	Earth slide
Spread	Rock spread	Debris spread	Earth spread
Flow	Rock flow	Debris flow	Earth flow

**Table 3-13** Glossary for forming names of landslides. From Cruden and Varnes (1996).

Description of Activity			Description of Movement	
State	Distribution	Style	Rate	Water Content
Active	Advancing	Complex	Extremely rapid	Dry Moist Wet Very wet
Reactivated	Retrogressive		Very rapid	
Suspended	Widening	Composite	Rapid	
Inactive	Enlarging	Multiple	Moderate	
Dormant	Confined	Successive	Slow	
Abandoned	Diminishing	Single	Very slow	
Stabilized	Moving		Extremely slow	
Relict				



**Figure 3-35** Cross-sectional and block diagrams of movement types on soil slopes. (A) Soil fall from steep slope; (B) Soil topple in coherent blocks of soil that experience an overturning moment; (C1) Rotational soil slide; (C2) Translational soil slide; (D) Soil flow; (E) Soil spread. Diagrams (A), (B) and (E) from Cruden and Varnes (1996); diagrams (C1), (C2) and (D) from U.S. Geological Survey website (2011).

### MECHANISMS OF MOVEMENT ON SOIL SLOPES

Movements on soil slopes can be broadly categorized into the five types listed in Table 3-12 and illustrated in Figure 3-35; falls, topples, slides, spreads and flows. Slope movements may also be

complex (experiencing different types of movement at different times) or composite (experiencing different types of movement at the same time, in different parts of the slide). See Cruden and Varnes (1996) for more details on the mechanics of various sliding behavior.

Soil mass movements can be highly variable in frequency, volume, energy, and runout (the distance material moves from the source). Soil falls and topples tend to be lower in volume, energy, and runout, but sometimes occur more frequently as cliffs retreat. Soil slides and flows (similar to debris flows, see Section 3.26) can have highly variable energy, volume, and runout, though flows tend to have greater runout than slides and can occur repeatedly along the same drainages. Soil slides can be larger than most other soil mass movements, with volumes up to millions of cubic feet. Soil spreads also tend to have lower energy and runout, though they can occur on much gentler slopes than most other mass movements.

Slope stability can perhaps be best understood as the product of two competing sets of forces; those driving material downslope, and those resisting such movement. The factor of safety of the slope is the ratio of resisting forces to driving forces. A factor of safety of unity or greater (i.e. a factor of safety  $\geq 1$ ) is considered to be stable, however, in the interest of conservancy, most design criteria require a factor of safety of 1.3-1.5 or greater. Generally, the factor of safety is computed using the following equation:

$$\text{Factor of Safety (FOS)} = \frac{\text{Summation of resisting forces}}{\text{Summation of driving forces}}$$

Driving forces are largely controlled by:

- Height of slope (taller slopes contain a greater mass of material)
- Angle of slope (on steeper slopes the direction of potential mass movement is closer to the line of action of the material weight)
- Water content (water adds weight to the material)
- Groundwater movement (flow of groundwater out of a slope may create seepage forces)

Resisting forces are largely controlled by:

- Material properties (shear strength, cohesion, internal friction angle)
- Discontinuity properties (shear strength, friction, water pressure)
- Groundwater levels (positive pore pressure reduces effective stress and shear strength)
- Vegetation (inhibits erosion, water infiltration and breakup of the soil mass)

## **POTENTIAL TRIGGERS OF MOVEMENT ON SOIL SLOPES**

- Intense rainfall
- Rapid snowmelt
- Increase of groundwater level or groundwater flow
- Loading of the slope or crest
- Removal of support from the slope toe



- Ground shaking from earthquakes, blasting or other construction activities
- Changes in soil strength or infiltration properties, perhaps by wildfire or the clearing of vegetation

## **SITE INVESTIGATION GOALS**

The following site investigation guidelines have been adapted and condensed largely from Turner and Schuster (1996).

- a) Establish if slopes in the area have a history of instability, show evidence of present instability, or have the potential for future instability (through review of existing information, aerial photograph study, including Google Earth or other internet or printed aerial images, and field reconnaissance)
- b) Monitor existing slope movements if any are suspected (through installation of monitoring equipment)
- c) Determine the subsurface composition and structure, and the groundwater level in potentially unstable slopes (through boring and geophysical methods)
- d) Monitor and model groundwater conditions within potentially unstable slopes (through installation of wells and piezometers)
- e) Measure the mechanical properties of materials in potentially unstable slopes (through field testing, sampling and laboratory testing)
- f) Construct cross sections of potentially unstable slopes, in order to assess their stability

## **SITE INVESTIGATION ACTIONS**

### **Review of Existing Information**

The purpose of reviewing existing information is to learn of the soil types and underlying geology, and to establish if slopes in the area have a history of movement.

Soil surveys (available online from U.S. Department of Agriculture), geologic and topographic maps (available from the U.S. Geological Survey or state geological surveys) provide information of topography, materials and structure that may indicate the potential for slope instability prior to conducting site visits.

Slopes that have experienced movement in the past are likely to move again under certain conditions. Information of past slope movements can usually be found in state highway departments, geologic surveys and university departments. Locations of landslides are often shown on various geologic or engineering geologic maps. Of interest are:

- Date and time of occurrence
- Failure type (indicated by size, shape, depth and distance of movement)
- Rate of movement
- Possible triggers (rainfall, toe removal, seismic event etc.)

## **Aerial Photograph Study and Field Reconnaissance**

The purpose of aerial photograph study and field reconnaissance is to identify characteristics of topography, geology, drainage and vegetation that may indicate potential instability, to recognize past and present slope movements, and to gain information for planning the subsurface investigation.

It is efficient to study aerial photographs, including Google Earth or other internet or printed aerial images before conducting site reconnaissance. Important relationships between topography, landforms and drainage patterns that may be difficult to correlate from ground level can be recognized from aerial photographs. Table 3-14 presents some relationships that may be identified in aerial photographs and used to assess the potential for slope instability in an area. Field indicators of past and present slope movements, such as are shown in Figures 3-33 and 3-34, can also be recognized in aerial photographs.

Site reconnaissance serves to supplement and check the information and conclusions drawn from the study of maps, soil surveys and aerial photographs. Basic geology, soil types, landforms, groundwater levels (from springs or seeps) and drainage patterns should be recognized. Field indicators of past and present slope movements, and potentially unstable slopes should also be recognized.

Particular attention should be paid to past and present slope movements, with the aim of identifying their type, depth, extent, rate of movement, age and the materials involved. The type of movement(s) that occurs on a slope dictates the type of modeling that can be performed.

Slopes that are deemed to be potentially unstable will be the focus of the subsurface investigation. Slope movements that may be current should be monitored with relevant equipment, as described below. Installing monitoring equipment early in an investigation allows time to collect information on movement and water conditions that may be helpful in designing further subsurface investigations.

If no evidence is found of potential slope instability, it may be unnecessary to proceed with a subsurface investigation.

## **Slope Monitoring Equipment**

Monitoring equipment on unstable slopes provides quantitative data of current slope movements. This information is of great use in understanding, modeling and predicting slope movements in the area, as well as safeguarding persons or installations that may be affected. Important questions to be asked of a current slope movement are:

- What is the type of movement?
- What are the lateral boundaries of the slide mass?
- What is the depth of the slide mass? Where are the shear planes?
- What is the rate of movement? Is the rate steady or variable?
- What factors are influencing the timing and rate of movement?

**Table 3-14.** Key to landforms and their susceptibility to landslides. To be applied to observations from site reconnaissance and aerial photography. Landslide potential 1 = susceptible to landslides; 2 = susceptible to landslides under certain conditions; 3 = not susceptible to landslides except in vulnerable locations. Adapted from Schuster and Krizek (1978).

Topography, Drainage and Landforms				Landform or Geologic Materials	Landslide Potential		
level terrain	Not elevated			Floodplain	3		
	Elevated	Uniform tones		Terrace, lake bed	2		
		Surface irregularities, sharp cliff		Basaltic plateau	1		
		Interbedded - porous over impervious layers		Lake bed, coastal plain, sedimentary plateau	1		
Hilly terrain	Surface drainage not well integrated	Disconnected drainage		Limestone	3		
		Deranged drainage, overlapping hills, associated with lakes and swamps in glaciated areas		Moraine	2		
	Surface drainage well integrated	Parallel ridges	Parallel ridges, dark tones		Basaltic hills	1	
			Trellis drainage, ridge-and-valley topography, banded hills		Tilted sedimentary rocks	2	
			Pinnate drainage, vertical sided gullies		Loess	2	
		Branching ridges, hill tops at common elevation	Pinnate drainage, vertical sided gullies		Loess	2	
			Dendritic drainage	Banding on slope		Flat-lying sedimentary rocks	2
				No banding on slope	Moderately to highly dissected ridges, uniform slopes		Clay shale
	Low ridges, associated with coastal features				Dissected coastal plain	1	
	Winding ridges connecting conical hills, sparse vegetation		Serpentinite	1			
	Random ridges or hills	Dendritic drainage	Low rounded hills, meandering streams		Clay shale	1	
			Winding ridges connecting conical hills, sparse vegetation		Serpentinite	1	
			Massive uniform rounded to A-shaped hills		Granite	2	
Bumpy topography in glaciated areas			Moraine	2			
Level to hilly, transitional terrain	Steep slopes			Talus, colluvium	1		
	Moderate to flat slopes			Fan, delta	3		
	Hummocky slopes with scarp at head			Old slide	1		



Some parameters of interest, and instrumentation that may be used, are listed in Table 3-15. Many monitoring instruments support automated data collection, whereby a datalogger in the field can collect data continuously. The use of computers and integrated networks allows for data to be available in real-time from remote locations.

**Table 3-15** Some parameters of interest when investigating current movements on soil slopes, and the instrumentation that may be used to monitor them.

	Parameter of Interest	Instrumentation
Surface	Horizontal or vertical displacement	Differential Global Positioning System (DGPS)
	Widening of tension cracks	Extensometer
	Surface tilting or block rotation	Tiltmeter
	Rainfall	Rain gauge
	Drainage	Pipe flow meter
	Changes in slope surface geometry	Scanning radar system, LiDAR scanning, Structure from Motion photogrammetry
Subsurface	Location of shear planes and detection of movement across them	Inclinometer
	Soil pressure	Pressure cell
	Groundwater level and pore pressure	Piezometer

## Borings

Borings in slope stability investigations enable the determination of subsurface stratigraphy and structure, the identification of existing failure surfaces, the investigation of groundwater conditions, and the collection of samples for laboratory analysis.

Borings should be located at regular intervals along the profile of suspected unstable slopes. The spacing of borings is influenced largely by the expected lateral variation of subsurface materials. Colluvial, alluvial and talus deposits are likely to have high lateral variation, aeolian and marine deposits are likely to be more consistent. The homogeneity of residual soils is directly related to that of the underlying bedrock.

Slope cross sections, described below, will need to be created largely from boring data. This should be considered when choosing boring locations

Boring depths should be influenced by the known geology, the expected failure modes and the nature of existing movements on comparable slopes. It is important to intercept material layers, discontinuities or bedrock surfaces that might be susceptible to shear displacement. In homogeneous soil profiles the depth of investigation should be based upon the maximum size of expected movement; as a rule of thumb the shear surfaces of rotational slides are rarely deeper than the width of the zone of movement.

When investigating old or existing movements borings should be made along the central axis, to enable the construction of useful and accurate cross-sections. As a minimum, borings should be located at the top, middle and bottom of the movement. It is also useful to place borings transversely across the movement. Borings may also be made in pertinent locations on adjacent slopes that are deemed to be stable, to provide comparative information.

## **Geophysical Methods**

The purpose of geophysical investigations on potentially unstable slopes is the same as that of boring; to determine subsurface stratigraphy and structure, to identify existing and potential failure surfaces, and to locate the groundwater table. Geophysical exploration is perhaps most efficient and of most value when calibrated from, and used to extend, existing borehole data.

Geophysical methods that may be useful include resistivity, seismic refraction, ground penetrating radar, gravity, magnetic surveying and borehole logging. The choice of method for a geophysical investigation is largely controlled by the ease of accessibility of the slope and the nature of the terrain and vegetation, as well as the equipment and budget available.

## **Piezometers**

Piezometers should be installed in potentially unstable slopes to monitor and model groundwater conditions, with the aim of answering the following questions:

- If groundwater exists, is it static or flowing?
- What are the upper and lower limits and slope of the groundwater table?
- What is the proximity of the groundwater table to the existing or potential failure surface?
- What is the highest phreatic or piezometric surface to be used in stability analyses?

Groundwater has great influence on slope stability, so it is important that groundwater conditions are properly understood before stability analyses are carried out. Groundwater conditions often fluctuate; observations should be conducted over extended time periods, and particularly during extended wet periods.

## **Field Testing**

The purpose of field testing on potentially unstable slopes is to assess the in-situ engineering properties of slope materials. Data from in-situ field testing may be more representative of actual conditions than that from laboratory testing as sample-taking always involves a level of disturbance and certain features of a soil profile may not be represented in a small sample.

Some field tests may be performed at desired intervals in the bottom of an advancing borehole; others are more large-scale and require the excavation of test pits. The field tests to be performed should be selected based upon the nature of the slope and the subsurface and the information required for slope modeling, as well as the equipment and budget available.

### ***Borehole Field Testing***

- Standard penetration test (SPT) (AASHTO T 206; ASTM D1586)
- Cone penetrometer test (CPT) (ASTM D3441)
- Vane shear test (AASHTO T 223; ASTM D2573)
- Dilatometer test (ASTM D6635)
- Pressuremeter test (ASTM D4719)
- Borehole shear test (Lutenegger and Hallberg, 1981)

### ***Large-Scale Field Testing***

- Plate bearing test (ASTM D1195)
- Large-scale, in situ direct-shear test (Monnet, 2015)

### **Sampling**

Materials from potentially unstable slopes should be sampled for laboratory testing to determine their index and engineering properties. Samples should be taken of all materials encountered in borings, and at regular depth intervals. Samples should be taken that represent suspected or potential failure planes. For assessment of soil engineering properties, undisturbed samples are required. Their method of retrieval depends largely upon the type of material. Near-surface materials may be sampled by the cutting of blocks from pits or trenches.

- Intact Block Sampling of Soils (ASTM D7015)

### **Laboratory Testing**

Laboratory testing of materials allows for the assessment of index and engineering properties. Of greatest importance is shear strength. Some useful laboratory tests are listed below:

- Triaxial Compression Test (UU) (AASHTO T 296; ASTM D2850)  
(CU) (AASHTO T 297; ASTM D4767)  
(CD) (ASTM WK3821)
- Direct Shear Test (CD) (AASHTO T 236; ASTM D3080)
- Simple shear test (ASTM D6528)

### **Slope Cross Sections**

Cross sections through potentially unstable slopes allow conceptual models to be created so that the failure mechanisms at work may be better understood. Cross sections drawn along the expected paths of material movement, are also required for slope stability analyses. Several section lines may be useful to characterize an unstable slope, especially larger slopes. Sections are typically parallel, but landslide geometry may necessitate lines that intersect one another.

The slope profile along a section line can be derived from topographic maps or, if more detail is desired, from surveying. Information from subsurface investigations should be included, such as

stratigraphy, bedrock surface, weak layers, possible failure zones or surfaces, and the water table. Where borings do not lie on the section line, it may be possible to infer subsurface conditions from boring locations that lie close by. Cross sections from which much of the subsurface condition is inferred should not be relied upon in stability analyses.

## **POSSIBLE MITIGATION OPTIONS**

Avoidance:

- Alternate route selection
- Bridging

Reduction of driving forces:

- Excavation of slope material - without destabilizing the slope toe
- Reduction of load on slope
- Reduction of slope angle
- Drainage of surface and subsurface water

Increase of resisting forces:

- Lowering of water table by surface and subsurface drainage
- Vegetating of slopes
- External and/or internal stabilization
  - In situ walls
  - Gravity walls
  - Reinforced soil
  - Toe buttresses

## **RECOMMENDED AND CITED REFERENCES**

Clague, J.J. and Stead, D., (Eds.) 2018. Landslides: Types, Mechanisms and Modeling. Cambridge University Press. 436 p.

Cruden, D.M. and Varnes, D.J. 1996. Landslides Types and Processes. *In* Landslides: Investigation and Mitigation (Turner, A.K. and Schuster, R.L., eds.), Transportation Research Board, Special Report 247, National Research Council.

Highland, Lynn M. 2008. The Landslide Handbook – A Guide to Understanding Landslides. *US Department of the Interior, US Geological Survey, Circular 1325*. Available from: <https://pubs.usgs.gov/circ/1325/>

Lutenegger, A., and Hallberg, G. 1981. Borehole Shear Test in Geotechnical Investigations. In: *Laboratory Shear Strength of Soil*, R. Yong and F. Townsend (eds.). West Conshohocken, PA: ASTM International, pp. 566-578.

McCalpin, J. 1984. Preliminary Age Classification of Landslides for Inventory Mapping. *In* Proceedings of the 21<sup>st</sup> Engineering Geology and Soils Engineering Symposium, University of Idaho, Moscow, pp. 99-120.

Monnet, G. 2015. Chapter 8: Direct Shear Tests In Situ. In: *In Situ Tests in Geotechnical Engineering*. Hoboken, NJ: John Wiley and Sons.

Schuster, R.L. and Krizek, R.J. (Eds.). 1978. *Landslides: Analysis and Control*. Transportation Research Board, Special Report 176, National Research Council.

Turner, A.K. and Schuster, R.L. (Eds.). 1996. *Landslides: Investigation and Mitigation*. Transportation Research Board, Special Report 247, National Research Council.

USGS. *Landslide Hazards*. [Online]. Available at:  
<https://www.usgs.gov/natural-hazards/landslide-hazards>

Varnes, D.J. 1978. Slope Movement Types and Processes. *In* *Landslides: Analysis and Control* (Schuster, R.L. and Krizek, R.J., eds.), Transportation Research Board, Special report 176, National Research Council.

### **3.21 UNSTABLE SLOPES IN SHALE, CLAYSTONE AND OTHER DEGRADABLE ROCKS**

#### **THREATS POSED TO ENGINEERED WORKS**

- Progressive decrease of slope stability with degradation of materials leading to slope movements
  - Damage to structures on, and at the toe of, slopes due to loss of support
  - Blockage of transportation routes and burial of installations below slopes

#### **FIELD INDICATORS OF SHALE AND CLAYSTONE**

- Fine-grained sedimentary rocks with considerable clay and quartz content
- Commonly gray, black (carbonaceous content), brown, red or green (ferric iron content)
- Joints are close and regularly spaced
- Shales are finely laminated and fissile (easily spilt along cleavage planes), thin pieces can be broken by hand
- The expansion of clay particles in shales often causes ‘fanning’ of cleavage when exposed to moisture (like the pages of an open book)
- “Popcorn” texture on weathered surfaces of poorly consolidated units

#### **CHARACTERISTICS OF SHALE AND CLAYSTONE TERRAIN**

- Slopes are likely to display hummocks and scarps from past slope movements
- Horizontal or shallow-dip bedding
  - low rounded hills
  - well integrated dendritic (tree-like) drainage systems
  - gentle swale-type gullies
  - contour-like stratification lines formed by beds of more resistant rock
- Steeply dipping bedding
  - parallel ridges (more resistant rock) and valleys (less resistant rock)

#### **MECHANISMS OF SHALE AND CLAYSTONE DEGRADATION**

Shales and claystones are formed from the accumulation and consolidation of fine particles of clay and silt. Upon exposure to air or water they degrade and lose strength. Some rocks are more durable than others; the rate of degradation depends largely upon the amount and type of clay contained, and their burial and unloading history.

During unloading shales and claystones expand and form joints at regular intervals. The formation of slopes reduces horizontal confining forces and forms vertical joints parallel to the slope face. At shallow depths these joints open and allow moisture to penetrate, initiating degradation (known as slaking). On recently exposed slopes, shales and claystones are prone to delayed and progressive failures.

The inherent problem with assessing the stability of slopes in degradable rock is their loss of strength over time; a slope that is considered stable after an initial site investigation may become unstable within the lifetime of the engineered works (Walkinshaw and Santi, 1996). Thus, if such slopes exist in close proximity to existing or proposed engineering works it is advisable to take preemptive action to prevent problematic slope movements, either by engineering cut-slopes or by stabilization of existing slopes.

## **MECHANISMS OF MOVEMENT ON CLAYSTONE AND SHALE SLOPES**

Downslope movement of shale or claystone material usually occurs as a continuous passage of small fragments as exposed rock weakens and breaks up. Movement may also occur as discreet mass movements, the character of which is influenced by the durability, homogeneity and, if interbedded, the thickness and geometry of the bedding. General characteristics of mass movements are given below:

### **Homogeneous Shale or Claystone**

- Slopes formed in weak shales or claystones with relatively homogeneous properties tend to fail along circular surfaces, as rotational slides or slumps. Advanced weathering and successive slides produce low-angle slopes.
- More durable rock demonstrates slope processes that are more rock-like; they are more likely to fail along discontinuities as coherent blocks and may form steeper slopes (see Section 3.19).

### **Interbedded Shale or Claystone**

- Beds of impervious rock retard deep weathering so overall slope angles are generally greater than those for homogeneous shale or claystone formations of comparable durability.
- The size of individual failures is limited by the thickness of weak deposits.
- Undercutting of more resistant rock may form overhangs and result in rock falls.
- Bedding dipping out of the slope allows weak materials to fail and slide down the slope along bedding planes.
- Horizontal bedding and bedding dipping into the slope cause bench-like slope profiles to develop, inhibiting the downslope movement of weak material.

## **ENGINEERING CHARACTERISTICS OF SHALE AND CLAYSTONE SLOPES**

Shale, claystone, and other easily-degradable rocks typically have low intact strengths, variable degrees of bedding, and variable thicknesses, resulting in weak, easily erodible slopes. Where shales and claystones are interbedded with more resistant rock, the shales and claystones will erode more quickly, undercutting the resistant layers and creating potential for rockfall. Because weak rocks are easily erodible, failures of these slopes dominated by weak rocks tend to involve more frequent small rockfall and raveling, or rotational landslides, since weak highly jointed rock behaves more like a soil than an intact rock mass.

## **SITE INVESTIGATION GOALS**

- a) Become familiar with the general geology, drainage patterns and performance of slopes in the area (through review of existing information and study of Google Earth or other internet or printed aerial photographs)
- b) Study the geology, drainage, groundwater conditions and performance of specific slopes that may affect the planned works (through site reconnaissance)
- c) Determine the subsurface stratigraphy and geometry, the weathering profile and the groundwater level in potentially unstable slopes (through boring)
- d) Construct cross sections of potentially unstable slopes (by combining the slope profile with subsurface information)
- e) Classify rock in the slope according to its durability, to allow for mitigation planning (through sampling and laboratory testing)

## **SITE INVESTIGATION ACTIONS**

### **Review of Existing Information**

The purpose of reviewing existing information is to become familiar with the general geology, drainage patterns and performance of slopes in the area.

Geologic maps (available from the US Geological Survey) provide information of rock types and structure. The occurrence of shales and claystones will be documented, commonly with details of their composition and weathering characteristics. Interbedded rock types, general bed thicknesses and general bedding angles are also documented.

Topographic maps (available from the US Geological Survey) allow topographic and drainage patterns in the area to be studied. Characteristic terrain features (listed above) can be recognized. Correlation of topographic and geologic maps helps to clarify the relationships between geology and topography in the area.

Investigation reports and performance assessments from previous engineering projects in the area that have involved slopes in shale or claystone are of great use. Interviews with persons who have local experience of slope engineering or performance may also be informative.

### **Aerial Photograph Study**

Aerial photographs (best viewed stereoscopically), and a review of other resources such as Google Earth or other internet or printed aerial images, can reveal more specific details of topography, landforms and surface features. The general performance of slopes can be assessed by identification of landslide features (such as hummocks and scarps), eroded beds, colluvial fans and overhangs of resistant rocks. Areas of interest should be noted for site reconnaissance.



## **Site Reconnaissance**

Site reconnaissance serves primarily to identify unstable and potentially unstable slopes that may affect the planned works. The size and abundance of slope movements, and the mechanisms at work should be recognized.

Rock types should be identified and their strength and weathering characteristics qualitatively assessed. Stratigraphy, bed thicknesses, bedding and discontinuity orientations should be recorded. Surface drainage above and on the slope should be assessed, and springs and seepage areas noted as indicators of groundwater levels.

If the geometry of rock outcrops is such that the movement of coherent blocks is possible a rock slope stability investigation should be considered (see Section 3.19).

## **Borings**

Borings aim to investigate the subsurface stratigraphy and weathering profile, to locate the groundwater table and to retrieve samples for laboratory analysis. Borings may be unnecessary if unstable slopes can be avoided.

The spacing and depth of borings depends upon the planned works, the desired level of subsurface information, and the mechanisms of slope movement taking place.

If an analysis of an existing or past slope movement is desired in order to back-calculate material strength parameters, borings should be placed at relevant locations and depths to characterize the slide materials and to locate the failure surface. It should be recognized, however, that the strength of shales and claystones is likely to diminish significantly with progressive weathering, and current or past strength properties may not be representative of future strength properties.

If significant cuts or excavations are to be made in a slope it may be useful to have subsurface information from borings. In this case borings should be spaced according to the planned works. The spacing of borings also depends upon the expected variability in subsurface materials and conditions. Boring depths should be at least to fresh, unweathered rock. The modeling of the water table requires that several borings, a good distance apart, should be deep enough to intercept groundwater.

Some laboratory tests (described below) require intact pieces of rock. If the engineering properties of subsurface rock is of interest, coring operations will be necessary. Other tests require only fragments of rock, such as cuttings from rotary or auger drilling.

## **Slope Cross Sections**

Cross sections are required for the design of cut-slopes. Slope profiles can be obtained directly from a topographic base map, but field surveying techniques allow for a higher degree of accuracy. Geologic features and groundwater indicators that have been mapped during site reconnaissance can be added to the slope profile and correlated with subsurface information from

borings. Subsurface information should include the types and depths of rock units, the depth of weathering zones and the groundwater table.

### **Sampling**

Samples should be taken so as to fully represent the different rocks in the slope, and the various stages of weathering in the same rocks. Several laboratory tests (described below) can be used to assess a rock's durability; the type of samples collected depends largely upon the tests to be performed:

- For each jar slake test, a single intact piece of rock is required, such as might be produced by rotary or auger drilling.
- For each slake durability test, the sample should consist of 10 intact pieces of rock, each weighing between 40 and 60 grams.
- For each point load test, a single intact piece of rock is required; pieces of core are ideal.
- For plasticity index testing, the sample will be pulverized to a fine consistency. Cuttings or rock core are both suitable.
- For each free swell test, an intact piece of rock core or a block sample is required.

### **Laboratory Testing**

Laboratory testing of shale and claystone for slope design is primarily aimed at assessing their durability and enabling their classification. The tests below are those required to determine strength-durability classification and shale rating. More tests would be required to fully evaluate rock engineering properties.

- Jar slake test (WSDOT T 501)
- Slake durability test (ASTM D4644)
- Point load test (ASTM D5731)
- Plasticity index (AASHTO T 90; ASTM D4318)
- Free swell test (Sivapullaiah et al., 1987)

### **Interpretation of Laboratory Results**

The strength-durability classification (Welsh et al., 1991) combines the jar slake index with the point load strength to categorize a rock into one of three classes: Class I, nondurable and weak; Class II, conditionally stable; Class III, durable and strong. The same classification system can be furthered by incorporation of the free swell index.

The shale rating system (Franklin, 1981) combines the slake durability index with the point load strength (if durability is greater than 80 percent) or slake durability index and plasticity index (if durability is less than 80 percent). The shale rating value, R, ranges from 0 to 9; 0 being the weakest and least durable. The shale rating system can be applied to other weak and degradable rocks.

State highway departments typically have standard plans to address cut-slope design in degradable rocks, based upon past experience. The various slope designs involve slope angle reduction or benching, the specifics of which largely depend upon the rock's strength-durability or shale rating, and the nature of bedding and jointing.

## POSSIBLE MITIGATION OPTIONS

- Avoidance
- Engineering of cut-slope
- Drainage of water (subsurface and surface)
- External stabilization (sheet piles, gabions, cantilever walls etc.)
- Internal stabilization (soil nails/anchors, reinforcing strips/grids, tie-backs etc.)
- Prevention of weathering (shotcrete etc.)

## RECOMMENDED AND CITED REFERENCES

- Duncan, J.M. and Dunlop, P. 1969. Slopes in Stiff-fissured Clays and Shales. *Journal of the Soil Mechanics and Foundation Division, American Society of Civil Engineers*, Vol. 95, No. SM2, pp. 467-492.
- Franklin, J.A. 1981. A Shale Rating System and Tentative Applications to Shale Performance. Transportation Research Board, Record 790, pp. 2-12. National Research Council.
- Martin, D. and Stacey, P. (eds.) 2018. *Guidelines for Open Pit Slope Design in Weak Rocks*. CSIRO Publishing. 398 p.
- Haneburg, W.C. and Anderson, S.A. 1995. *Clay and Shale Slope Instability*. Boulder, CO: Geological Society of America.
- Santi, P.M. 1997. Comparison of Weak and Weathered Rock Classification Systems. *In Characterization of Weak and Weathered Rock Masses* (Santi, P.M. and Shakoor, A., eds). Association of Engineering Geologists Special Publication No. 9.
- P. Sivapullaiah, T. Sitharam, and K. Subba Rao, "Modified Free Swell Index for Clays," *Geotechnical Testing Journal* 10, no. 2 (1987): 80-85. <https://doi.org/10.1520/GTJ10936J>
- Walkinshaw, J.L. and Santi, P.M. 1996. Shales and Other Degradable Materials. *In Landslides: Investigation and Mitigation* (Chapter 21). Transportation Research Board, Special Report 247. National Research Council.
- Welsh, R.A., Jr., Vallejo, L.E., Lovell, L.W. and Robinson, M.K. 1991. The U.S. Office of Surface Mining (OSM) Proposed Strength-Durability Classification System. *In Proceedings of the Symposium on Detection and Construction at the Soil/Rock Interface*. American Society of Civil Engineers, Geotechnical Special Publication No. 28.

Withiam, J.L. and Andrews, D.E. 1982. Relevancy of Durability Testing of Shales to Field Behavior. Transportation Research Board, Record 873, pp. 36-42. National Research Council.

WSDOT. 2017. Test Method to Determine Durability of Very Weak Rock. Washington State Department of Transportation, Test Method T 501. Available from:

<https://www.wsdot.wa.gov/publications/manuals/fulltext/M46-01/t501.pdf>

77

## 3.22 TALUS

### THREATS TO ENGINEERED WORKS

- Voids in subsurface resulting in poor foundation conditions and difficult grouting
- Loose or unstable rock blocks
- Deposits of highly variable thickness and extent (sometimes interbedded with other sediments)

### FIELD INDICATORS OF TALUS

- Sheets or cones of loose rock fragments on sides or bottom of valley
- Talus can be obscured by vegetation or interbedded with alluvium (Trapani et al., 2003)

### OCCURRENCE OF TALUS

Talus consists of rock fragments formed from the rapid physical fragmentation of bedrock exposed on steep slopes. As shown in Figure 3-36, talus accumulates at the base of slopes to form wedge-shaped deposits. As talus rolls downslope it is often funneled into chutes by the surface morphology to form talus cones. Transportation routes in mountainous regions often follow valleys and canyons where talus slopes are common and extensive, on slopes and as valley fill. Talus deposits may be overlain by more recent colluvial or alluvial sediments.



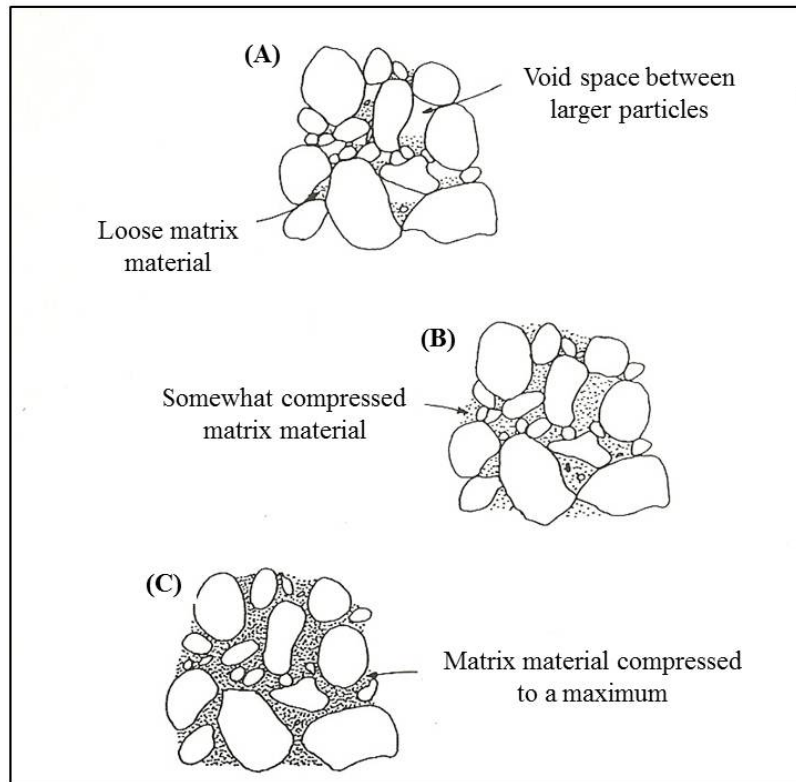
**Figure 3-36** Talus slope below the cliffs of the caldera rim, Chaski Bay, Crater Lake National Park, Oregon (left) (Image taken by C. Bacon, 2008; available from: <https://www.usgs.gov/media/images/crater-lake-chaski-bay-talus-slope-sits-flat-top-massive-sl>) ; talus cones in Svalbard, Norway (right) (Wikipedia commons, 2009)

### ENGINEERING CHARACTERISTICS OF TALUS

The grain size distribution, void ratio and engineering properties of a single talus deposit may be highly variable in three dimensions. Talus deposits are commonly stratified sub-parallel to the slope surface. Boulders up to meters in diameter may exist anywhere within the deposit, as may

large voids. Talus slopes are usually armored with larger rock fragments that do not represent the character of the deposit below (Turner, 1996).

Over time talus deposits commonly become in-filled by fine material transported by wind or water. Depending upon the amount of fine infilling material, a talus deposit may be clast-supported, matrix-supported or intermediate between the two, (Figure 3-37). Different levels of matrix support may exist in different parts of the same deposit. Talus that is dominantly clast-supported distributes load pressure through point contacts and may be unstable when loaded due to the realignment of rock fragments.



**Figure 3-37** Cross section through three classes of in-place rockfill; largely representative of talus deposits: (A) clast-supported, (B) intermediate, and (C) matrix-supported. Modified from Clift (1994).

Since talus deposits are in a loose state, the slopes are naturally inclined at their angle of repose. If an un-supported cut-slope is made that is steeper than the natural angle of repose, it will progressively fail to regain the natural angle.

Talus deposits are unlikely to be mobilized as debris flows, but the chutes through which talus is channeled may act as conduits for debris flows originating upslope. The possibility of downslope creep of talus deposits has been postulated and, although studies have shown little evidence of such behavior, it is theoretically possible especially in the near-surface.

Talus originates from rockfall. Talus deposits form the run-out zones from rockfall source zones on slopes and cliffs above. Engineering works that are in proximity to talus are potentially threatened by rockfall.

## **SUBSURFACE INVESTIGATIONS OF TALUS**

Conventional subsurface penetration and investigation techniques are very often ineffective in talus due to the large size of many rock fragments, the abundance of void space and the lack of cohesion.

Drilling operations in talus suffer from uneven bit loading and frequent loss of circulating fluid. During the construction of Interstate 70 the Colorado Department of Transportation (CDOT) cooperated with manufacturers to develop wire-line core drilling bits and procedures to successfully drill test holes in talus (Trapani et. al, 2003). Because excavations in talus may collapse rapidly, talus deposits are among the most dangerous in which to perform steep-sided excavations. Obtaining undisturbed samples of talus is almost impossible due to the presence of large fragments and the lack of cohesion.

For these reasons the problems posed by talus have in the past been addressed by mitigation techniques that are largely irrespective of the site-specific properties of a talus deposit. If a talus slope cannot be avoided it must either be cut back or built upon. In the case of former it is necessary to install sufficient external stabilization, for which it is useful to know the general level of matrix support. In the case of the latter it is necessary to install deep foundations, for which it is useful to know the depth to bedrock.

## **SITE INVESTIGATION GOALS**

- a) Determine the depth of talus deposits, and the general level of matrix support (through boring)
- b) Assess the rockfall hazard from source zones above the talus deposit (see Section 3.19).

## **SITE INVESTIGATION ACTIONS**

### **Borings**

The purpose of boring in talus is primarily to locate bedrock; this information is important for the design of deep foundations. Furthermore, drilling responses such as fluid loss, vibration, weight-on-bit and penetration rate can be interpreted by experienced personnel as general indicators of the nature of the talus at depth such as void size, grain size and relative density, from which the level of matrix support can be roughly assessed.

The spacing of borings depends largely upon the nature of the planned works.

## **POSSIBLE MITIGATION OPTIONS**

- Avoidance

- Ground anchors for slope stabilization, using grout containment devices (GCD) where necessary (Bowen, 1998)
- Back-filling of voids
- Pile foundations, installed after pre-blasting to facilitate installation

## **RECOMMENDED AND CITED REFERENCES**

Bowen, T. 1988. Expendable Membrane Ground Anchors in Talus. U.S. Department of Transportation, Report No. FHWA-DP-89-068-006.

Clift, A.E. 1994. In Situ Properties and Characteristics of Rock Fill. Ph.D. Thesis No. T-4375. Colorado School of Mines, Golden, CO.

Colorado School of Mines and Colorado Department of Highways. 1984. Guidebook to the Engineering Geology and Interstate Construction in Glenwood Canyon.

Luckman, B.H. 2013. Talus Slopes. *In: Encyclopedia of Quaternary Science*, 2<sup>nd</sup> Ed. (Elias, S.A. and Mock, C.J., eds.), pp. 566-573.

Trapani, R., Andrew, R. and Pihl, R. 2003. Innovation by Teamwork: Engineering Geology of Interstate 70 Through Glenwood Canyon. *In Engineering Geology in Colorado: Contributions, Trends and Case Histories* (Boyer, D.D., Santi, P.M. and Rogers, W.P., eds.). Association of Engineering Geologists, Special Publication No. 15. Colorado Geological Survey, Special Publication 55.

Turner, A.K. 1996. Colluvium and Talus. *In Landslides: Investigation and Mitigation* (Chapter 20). Transportation Research Board, Special Report 247. National Research Council.



### 3.23 SEISMIC HAZARDS

#### THREATS POSED TO ENGINEERED WORKS

- Ground motion
  - Structural damage and collapse
- Ground failure
  - Soil liquefaction
  - Ground settlement due to soil compaction
  - Slope instability
  - Surface fault rupture

#### IDENTIFICATION OF AREAS AFFECTED BY SEISMIC ACTIVITY

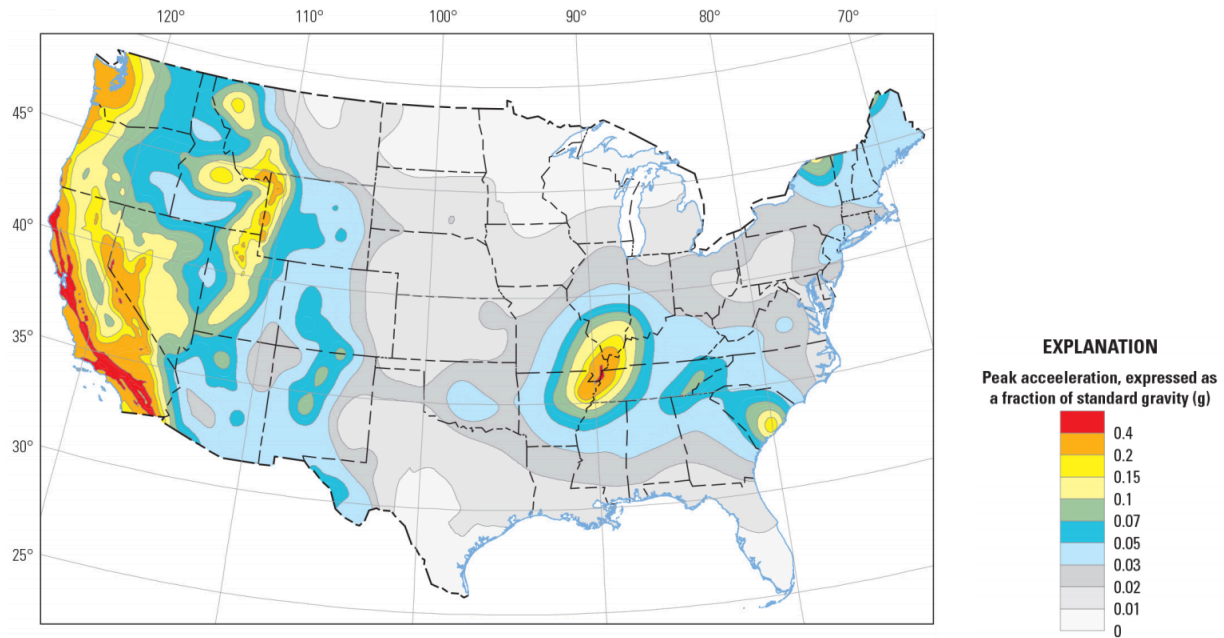
The US Geological Survey (USGS) National Seismic Hazard Mapping Project has produced hazard mapping images and data for the entire US that is available online. The maps are of probabilistic ground motion (in gravity units) caused by seismic events of given spectral acceleration (in Hz) and return period from known seismic sources. The AASHTO seismic design criterion specifies design for a seismic event with a 7% probability of occurrence in 75 years (AASHTO, 2017). This describes an event with a 1000-year recurrence interval. Figure 3-38 shows peak ground acceleration for a 10% probability of exceedance in 50 years, and is included to give a sense of the relative seismic hazard throughout the U.S. The USGS has many such maps for different PGAs and return periods, as well as more detailed maps for specific states and regions.

#### FACTORS INFLUENCING GROUND MOTION

Ground motion is a result of seismic waves propagating from the focus of the earthquake. The ground motion experienced at a particular location is influenced by:

- Magnitude – characteristic of the energy released at the focus: higher magnitude earthquakes produce more ground motion at a given location
- Frequency – the wavelength of seismic waves: higher frequency waves generally produce more ground motion for a given location
- Distance – the energy of seismic waves is dissipated as they travel from the focus
- Geologic environment – the attenuation of seismic waves depends upon material properties; ground motions can be amplified by unconsolidated sediments and certain types of sedimentary rock, while bedrock at the surface tends to experience less shaking.

The influence of magnitude, frequency and distance are accounted for by the USGS seismic hazard maps. The influence of subsurface materials on ground motion and the resulting hazards of liquefaction, settlement and slope instability must be assessed by site investigation. Similarly, the threat posed by faults must be assessed by site investigation.



**Figure 3-38** Peak ground acceleration for a 10% probability of exceedance in 50 years. This map gives a sense of the relative seismic hazard in the U.S. (Figure 4A from USGS, 2014).

## SEISMIC HAZARDS

### Liquefaction

Liquefaction is the process by which a soil drastically reduces in strength and enters into a liquefied state when subjected to dynamic loading, such as that produced by seismic shear waves. Liquefaction affects saturated cohesionless soils (typically sand, silty sand, poorly-graded fine sand, clayey sand or gravelly sand) at depths less than about eighty feet. Earthquake shaking causes the soil to compact, increasing the pore pressure and reducing the effective stress and soil strength. The strength of the soil is restored once the excess pore pressure has dissipated, but by this time the liquefaction event may have caused:

- Reduction in bearing capacity as soil strength is reduced
- Lateral spreading of overlying competent soil layers
- Increased pressure on retaining walls as internal friction of soil is reduced
- Flow slides on slopes
- Ground settlement after excess pore pressure is dissipated

An evaluation of the potential for, and the consequences of, liquefaction should be made according to the seismic hazard level (based upon the spectral acceleration), the potential magnitude of the event, the depth of the water table and the nature of the soils below it. Specific guidelines indicating whether such an evaluation is necessary can be found in Kavazanjian et al. (1998). An investigation into liquefaction potential involves:

- Locating the water table

- Identifying potentially liquefiable soils beneath the water table and above the maximum depth of liquefaction (about 80 feet)
- Assessing the liquefaction potential of soils through field testing techniques

It is important to monitor the groundwater table for a sufficiently long period of time to characterize seasonal fluctuations. In order to be conservative, the maximum height reached for a sustained period of time should be the height used for assessing liquefaction potential. Visual inspection of cuttings and samples can initially identify potentially liquefiable soils. Basic analyses of soil properties can further indicate liquefaction potential. In general, the following properties are indicative of liquefiable soils:

- $D_{10}$  size fraction is between 0.01 and 0.25mm
- Coefficient of uniformity between 2 and 10
- Relative density less than 75%
- Normalized standardized SPT ( $SPT_N$ ) values less than 25

The cyclic resistance ratio (CRR, a measure of resistance to liquefaction) of a soil can be quantified by cyclic loading tests in the laboratory, or by field tests. Due to the difficulty of taking undisturbed samples of saturated cohesionless soils, it is now standard practice to use SPT, CPT, or shear wave velocities to evaluate the CRR, either empirically or through numerical modeling. The method of empirical evaluation of CRR is detailed by Kavazanjian et al. (1998). Ground settlement may also occur after consolidation of soil layers that have undergone liquefaction. The procedure for evaluating such settlement is described by Kavazanjian et al. (1998). It involves the use of charts to extrapolate volumetric strain from field data. Required information includes:

- Knowledge of the soil profile including depths and thicknesses of liquefiable layers
- For each liquefiable layer
  - $SPT_N$  blow counts
  - CRR (calculated from SPT, CPT or shear wave data)

### **Ground Settlement due to Soil Compaction**

Earthquake induced ground shaking can induce significant compaction in dry or unsaturated cohesionless soils by causing grain rearrangement to a closer, denser configuration. This compaction is accompanied by surface subsidence. The amount of surface subsidence depends upon the vertical thickness and the change in density of the compacted layer. Differential settlement is also possible.

The procedure for evaluating settlement due to compaction of dry, cohesionless soils under seismic loading is described by Kavazanjian et al. (1998). It involves the use of charts to evaluate volumetric strain after calculating the normalized effective stress on each compactible layer and the earthquake-induced shear strain after construction. Required information includes:

- Knowledge of the soil profile including depths and thickness of compactible layers
- For each compactible layer

- Unit weight
- Normalized standardized SPT blow counts
- Shear wave velocity
- Mass density

### **Slope Instability**

Seismic ground accelerations produce inertial forces that are not accounted for by static analyses of slope stability. Seismically affected slopes are usually less stable and may have different critical surfaces than equivalent slopes in a static state. Current practice for seismic slope stability analyses involves either limit-equilibrium or displacement-based methods. These methods are described by Kavazanjian et al. (1998) and Kavazanjian et al. (2011).

While the stability-modeling of slopes under seismic conditions requires specific methods, the required information of geometry and materials is the same as for static conditions. Guidelines for slope stability investigations are described in Sections 3.19, 3.20 and 3.21.

### **Surface Rupture**

Surface rupture is only a hazard to structures built on or across active faults or fault zones (having sustained movement within the last 11,000 years) which may sustain displacement at the ground surface or at the level of foundations. Active faults may be indicated by geological, historical or seismological criteria (see Cluff et al. 1972; Hanson et al., 1999). In the interest of a thorough investigation, it is advisable to consider all criteria. Consultation with geologists who are knowledgeable about the area is recommended.

## **AASHTO SITE CLASSIFICATION FOR SEISMIC BRIDGE DESIGN**

AASHTO has defined classes for sites based upon rock and soil properties (AASHTO, 2017). The site classification is used to characterize the seismic hazard at the site, which in turn influences the required site-specific investigations and design measures. The site class definitions are shown in Table 3-16. Detailed guidance on the assignment and interpretation of site class is given in the AASHTO LRFD Bridge Design Specifications manual. Other transportation structures, such as culverts and tunnels, do not necessarily have federally adopted design codes, so only the site evaluation criteria from the AASHTO Bridge Design manual are included here. The information required to classify a site for seismic bridge design includes:

- Soil profile and depth to bedrock
- Shear wave velocities of upper 100ft of soil profile
- Shear wave velocity of bedrock (if within 100ft of surface)
- SPT blow count for the upper 100ft of soil profile
- Average undrained shear strength of the upper 100ft of soil profile
- Plasticity index and moisture content for any clay layers thicker than 10ft within the upper 100ft of soil profile.

**Table 3-16** Site class definitions specified by AASHTO for seismic design of bridges.  $v_s$  = shear wave velocity;  $N$  = SPT blow count;  $s_u$  = average undrained shear strength;  $PI$  = plasticity index;  $w$  = moisture content. From AASHTO (2017).

Site Class	Soil Type and Profile
A	Hard rock with $v_s > 5,000$ ft/s
B	Rock with $2,500$ ft/s $< v_s < 5,000$ ft/s
C	Very dense soil and rock with $1,200$ ft/s $< v_s < 2,500$ ft/s, <i>OR</i> with $N > 50$ blows/ft, <i>OR</i> with $s_u > 2.0$ ksf
D	Stiff soil with $600$ ft/s $< v_s < 1,200$ ft/s, <i>OR</i> with $15$ blows/ft $< N < 50$ blows/ft, <i>OR</i> $1.0$ ksf $< v_s < 2.0$ ksf
E	Soil profile with $v_s < 600$ ft/s, <i>OR</i> with $N < 15$ blows/ft, <i>OR</i> with $s_u < 1.0$ ksf, <i>OR</i> with more than 10ft of soft clay with $PI > 20$ , $w > 40\%$ and $s_u < 0.5$ ksf
F	Soils requiring site-specific evaluation, such as: <ul style="list-style-type: none"> <li>• Peats or highly organic clays (of depth greater than 10ft)</li> <li>• Very high plasticity clays (of depth greater than 25ft and with <math>PI &gt; 75</math>)</li> <li>• Very thick soft/medium stiff clays (of depth greater than 120ft)</li> </ul>

## SITE INVESTIGATION GOALS

- a) Determine the probable ground motion at the site for the specified design level of the project (through USGS Seismic Hazard Maps)
- b) Investigate the subsurface profile (through boring)
- c) Locate and monitor the water table (through installation of wells or piezometers)
- d) Classify the site according to the AASHTO Site Classification for Seismic Bridge Design, or another seismic design site classification system if available (through field testing, sampling, laboratory testing and geophysical methods)
- e) Determine if soil layers exist in the profile that are susceptible to liquefaction or compaction (through field testing, sampling, laboratory testing and geophysical methods)
- f) If soil or rock slopes exist on the site, a seismic slope stability investigation should be conducted (as described above)
- g) Determine if surface rupture is a hazard (as described above)

## SITE INVESTIGATION ACTIONS

### USGS Seismic Hazard Maps

As described above, the US Geological Survey (USGS) National Seismic Hazard Mapping Project has produced hazard mapping images and data for the entire US that is available online. These maps show levels of expected ground motion for seismic events of specified size and recurrence rate.

## Borings

Borings aim to investigate the subsurface profile and locate bedrock. While boring, preliminary inspection of soil materials may indicate potential hazards or site classification; sandy layers are of particular interest in the search for liquefiable or compactible layers, highly organic or clay-rich layers may have some influence on site classification.

Borings typically need only be to a depth of 100 feet (to capture all potentially liquefiable units), or to bedrock. The spacing of borings depends largely upon the planned engineering works.

## Wells or Piezometers

The depth to the water table is important in the assessment of slope stability and liquefaction potential. It is important to monitor the groundwater table for a sufficiently long period of time to characterize seasonal fluctuations. In order to be conservative, the maximum height reached for a sustained period of time should be the height used for assessing liquefaction potential.

## Field Testing

Field-testing in seismic investigations is useful in assessing the physical properties of subsurface materials, especially materials that are difficult to sample without disturbance such as sandy and cohesionless soils. Field testing is required at a minimum for the measurement of relative density to be used in liquefaction assessment. Recommended procedures include:

- Standard penetration test (SPT) (AASHTO T 206; ASTM D1586)
  - For liquefaction and settlement potential, and site classification
  - Allows for the measurement of
    - Relative density
    - Shear strength of cohesionless soils
    - Shear wave velocity
    - Cyclic resistance ratio (CRR)
  
- Cone penetration test (CPT) (ASTM D3441)
  - For liquefaction potential
  - Allows for the measurement of
    - Relative density
    - Unit weight
    - Shear strength
    - Shear wave velocity
    - Cyclic resistance ratio (CRR)

For investigations determining the location and extent of liquefiable deposits, a CPT rig with continuous recovery is preferred over standard SPT testing.

## Geophysical Methods

In seismic investigations geophysics is used primarily to measure the shear wave velocities of materials. This parameter is required for the assessment of liquefaction and settlement potential, and for site classification. Geophysical methods may also be used to locate bedrock.

Seismic reflection and refraction methods may be performed from the ground surface or from boreholes (cross-hole, down-hole or up-hole). Borehole surveying allows for the targeting of specific stratigraphic layers and produces greater accuracy than surface surveying.

## Sampling

Samples of soil and rock are necessary to measure their index and engineering properties in the laboratory. Samples should be taken of all soil units encountered.

Undisturbed samples are necessary for most of the laboratory tests listed below. It is likely to be difficult to obtain undisturbed samples of certain soil types, in which case it is recommended that field tests and geophysical methods be used to deduce physical properties wherever possible.

## Laboratory Testing

Laboratory tests to obtain the soil parameters for the AASHTO seismic site classification are listed below. Some tests may be unnecessary if the required parameter can be more easily or more accurately established through field testing or geophysical methods.

General soil properties (to characterize potentially liquefiable soils):

- Grain size distribution (AASHTO T 88; ASTM D6913)
- Density and unit weight (ASTM D7263)
- Relative density (ASTM D4254 / D4253)

Cyclic stress-strain parameters (modulus reduction and damping curves, cyclic resistance ratio):

- Cyclic triaxial strength (ASTM D5311)
- Cyclic direct simple shear (ASTM D8296)
- Torsional ring shear (ASTM D7608)
- Resonant column test (ASTM D4015)

Peak and residual shear strength (tests should be performed on both undisturbed and remolded samples in the CU state):

- Simple shear test (ASTM D6528)
- Triaxial compression test (CU) (AASHTO T 297; ASTM D4767)

## **POSSIBLE MITIGATION OPTIONS**

### ***Soil Liquefaction***

- Avoidance
- Structural design to accommodate liquefaction (anchoring of foundations below liquefiable soils, foundations designed to withstand lateral flow and downdrag)
- Remediation measures to reduce liquefaction potential
  - In-situ densification
  - Deep soil mixing using cement
  - Dewatering of liquefiable soils

### ***Ground Settlement Due to Soil Compaction***

- Avoidance
- Pre-compaction (dynamic or vibratory)

### ***Rock and Soil Slope Stability***

- Refer to Sections 3.19, 3.20, and 3.21

### ***Surface Rupture***

- Avoidance

## **RECOMMENDED AND CITED REFERENCES**

Association of State Highway and Transportation Officials (AASHTO). 2017. AASHTO LRFD Bridge Design Specifications, 8<sup>th</sup> Ed.

Anderson, G.G., Martin, G.R., Lam, I. and Wang, J.N. 2008. Seismic Analysis and Design of Retaining Walls, Buried Structures, Slopes and Embankments. National Cooperative Highway Research Program, Report No. 611. Transportation Research Board.

Cluff, L.S. and others. 1972. Site Evaluation in Seismically Active Areas – An Interdisciplinary Team Approach. Proceedings of the International Conference on Microzonation for Safer Construction Research and Application, Seattle, WA., Vol. 2, pp. 957-987.

Hanson, K.L., Kelson, K.I., Angell, M.A., and Lettis, W.R. 1999. Techniques for Identifying Faults and Determining Their Origins. U.S. Nuclear Regulatory Commission, Office of Nuclear Regulatory Research, Division of Engineering Technology, Report No. NUREG/CR-5503. Available from: <https://www.nrc.gov/docs/ML0930/ML093070145.pdf>.

Hovius, N., and Meunier, P. 2012. Earthquake Ground Motion and Patterns of Seismically Induced Landsliding. In: Landslides: Types, Mechanisms, and Modeling, Clague, J.J. and Stead, D. (eds.). Cambridge University Press.



Huang, Y. and Yu, M. 2017. Hazard Analysis of Seismic Soil Liquefaction, 1<sup>st</sup> Ed. Singapore: Springer Singapore.

Kavazanjian, E. Jr., Matasovic, N., Hadj-Hamou, T. and Wang, J. 1998. Geotechnical Engineering Reference Manual. U.S. Department of Transportation, Report No. FHWA-HI-99-012.

Kavazanjian, E. Jr., Wang, J., Martin, G., Shamsabadi, A., Lam, I., Dickenson, S.E. and Hung, C.J. 2011. LRFD Seismic Analysis and Design of Transportation Geotechnical Features and Structural Foundations Reference Manual. U.S. Department of Transportation, Report No. FHWA-NHI-11-032.

Oliveira, C.S., Roca A., and Goula, X. 2006. *Assessing and Managing Earthquake Risk: Geoscientific and Engineering Knowledge for Earthquake Risk Mitigation – developments, tools, techniques*. Springer, Dordrecht.

Petersen, M.D., Moschetti, M.P., Powers, P.M., Mueller, C.S., Haller, K.M., Frankel, A.D., Zeng, Yuehua, Rezaeian, Sanaz, Harmsen, S.C., Boyd, O.S., Field, Ned, Chen, Rui, Rukstales, K.S., Luco, Nico, Wheeler, R.L., Williams, R.A., and Olsen, A.H., 2014, Documentation for the 2014 update of the United States national seismic hazard maps: U.S. Geological Survey Open-File Report 2014–1091, 243 p., <https://dx.doi.org/10.3133/ofr20141091>.

United States Geological Survey (USGS). 2020. Earthquake Hazards Program, Seismic Hazard Maps and Site-Specific Data. <https://www.usgs.gov/natural-hazards/earthquake-hazards/seismic-hazard-maps-and-site-specific-data>

United States Geological Survey (USGS). 2020. Earthquake Hazards Program, Seismic Design Maps for Engineers. <https://www.usgs.gov/natural-hazards/earthquake-hazards/design-ground-motions>

## 3.24 ACTIVE VOLCANIC HAZARDS

### THREATS POSED TO ENGINEERED WORKS

- Direct damage to structures from active volcanic eruptions (lava flow, pyroclastic flow, ash fall, volcanic bombs)
- Secondary slope instability triggered by volcanic activity (lahars, debris avalanches, rock avalanches, etc.) (see Sections 3.19 and 3.20)
- Seismicity (see Section 3.23);
- Ground movement, including edifice formation or failure, heave, cracks, and settling
- Flooding due to changes in drainage patterns from new deposition
- Tsunamis, triggered by eruptions or associated mass-wasting or seismicity (Section 3.23)

### FIELD INDICATORS OF ACTIVE VOLCANIC HAZARDS

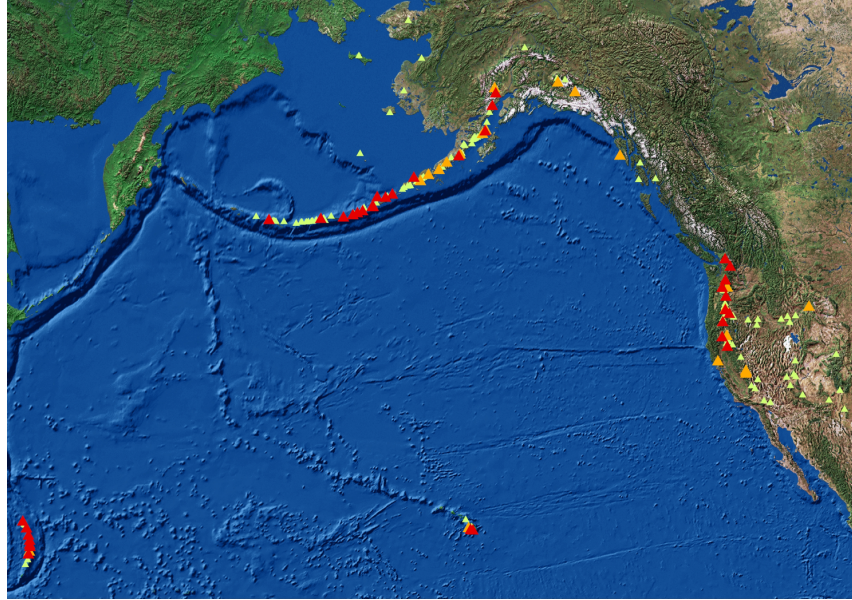
- Geographic area
- Active eruptions or venting of gases (fumaroles)
- Landforms such as volcanic cones, craters, and lava tubes
- Geothermal activity, including geysers and hot springs
- Volcanic deposits including ash, lava flows, and lahar deposits
- Extrusive rock types such as rhyolite, andesite, basalt, and tuff

### OCCURRENCE OF ACTIVE VOLCANIC HAZARDS

Volcanoes are mounds, hills, or mountain surface features that are created from extrusion of lava or pyroclastic material from a magma source (Fisher et al., 1997). Volcanic terrain hazards can occur at a range of distances from the volcano, and they decrease with increasing distance from the volcano.

The United States and its territories have 169 volcanoes and nearly half of these are considered dangerous due to the risk they impose on nearby communities (USGS, 2006a). Frequently, volcanoes occur along crustal plate boundaries and above mantle hot spots. Volcanic terrain is also encountered within continents, where extensional fissures produce large basalt deposits called, flood basalts.

In the United States, active volcanic hazards primarily exist in the contiguous Western states, Alaska, Hawaii, and the Mariana Islands (including Guam). Figure 3-39 shows a map of the U.S. and territories illustrating selected volcanoes that are of concern in the National Volcano Early Warning System (NVEWS) (USGS, 2006a).



**Figure 3-39** Map of volcanoes located in the western U.S. and its territories. Red triangles indicate volcanoes of highest priority for early warning. Orange indicates volcanoes of high priority, and green indicates other volcanoes (USGS 2006a).

Volcanoes are typically divided into three categories based on their activity levels: active, dormant, and extinct (USGS, 2015). In general, a volcano is considered active if it has erupted in historic (recorded) time and/or is currently erupting, has unusual earthquake activity, or has significant gas emissions. A dormant volcano is one that is not active currently, but could become active again. A volcano is classified as extinct if it is unlikely to erupt again. Because volcano activity classifications are qualitative (and can change when new data becomes available), this document divides volcanic hazards into two categories:

- Volcanic hazards that require active volcanism as a cause or trigger. These hazards arise only in areas with active volcanoes (explained in this section).
- Hazards arising from the properties of volcanic materials and aspects of volcanic terrain regardless of the current activity level of the volcano. These hazards arise both in areas with active volcanoes and those where the volcanism is dormant or extinct (explained in Section 3.25).

The USGS Volcano Hazards Program provides on-line resources such as data, maps, alerts, and hazard assessments for volcanic areas (USGS, 2015). Included on the USGS Volcano Hazards Program website are contact information and websites for the five U.S. volcano observatories: Alaska, California, Cascades, Hawaii, and Yellowstone.

## **MECHANISMS AND ENGINEERING CHARACTERISTICS OF ACTIVE VOLCANIC HAZARDS**

The following descriptions of volcanic features, processes, and related hazards have been adapted and summarized largely from Fisher et al. (1997), Goodman (1993), and the USGS

Volcano Hazards Program (USGS, 2015). Additional references for active volcanic hazards include Papale (2015) and Loughlin et al. (2015).

### Active Volcanism and Lava Flows

The types of volcanoes and eruptive styles are reflective of geology, magma composition, tectonic conditions, and water interaction. The differing volcanic environments result in different types of volcanoes, and thus a variety of deposits. There are four main types of volcanoes: cinder cones, composite, shield, and lava domes.

- *Cinder cones*: Cinder cones have a single vent and are created by accumulation of scoria (cinders). As gases build and rapidly expand in the magma, explosive eruptions occur and release pyroclastic materials such as ash, lapilli, and bombs. Due to rapid cooling of lava and the presence of gases, the cinder pieces frequently have many vesicles (air pockets). Deposition of scoria results in a steep cone-shaped mound with a crater at the top, that is typically around 1000 ft. high or less. These volcanoes are abundant in the western U.S., and can occur in clusters or on the flanks of composite and shield volcanoes.
- *Composite volcanoes*: Composite volcanoes are typically large and steep-sided and result from multiple and varying types of eruptions, including extrusion of pyroclastic particles, tephra, and lava flow. There can be a wide range of magma composition. Composite volcanoes typically have a crater at the top with a central vent or a cluster of vents. Extrusion of lava can occur through these vents or can be released from breaks in the flanks of the volcano.
- *Shield volcanoes*: These volcanoes are large, broad, and have low angle slopes. Shield volcanoes are formed by the accumulation of deposits of lower viscosity basaltic lava flows, generally in either the “pahoehoe” (smooth, pillowy, or ropy) and/or “a`a” (blocky, fragmented, and rough depending on the viscosity or rate of shear of the lava flow) styles. These basaltic flows can occur from central vents or from fissures, and can create broad plateaus of basalt deposits as seen in Washington, Oregon, and Idaho. Other types of volcanoes can occur on the flanks of shield volcanoes.
- *Lava domes*: These are often found within craters of composite volcanoes or on their flanks. They are small masses of viscous silica-rich lava (such as dacite and rhyolite magma composition), built from accretions of lava extruding from their vent. Since the lava is viscous, it does not flow far, and thus creates small dome features. Collapsing of lava domes can trigger pyroclastic flows.

Magma composition and supply tend to control the eruptive style of a volcano, which in turn affects the spatial extent and violence of eruptions. More viscous magma types, such as rhyolite and dacite, flow more slowly and cause more pressure to build up in the magma chamber, resulting in less-frequent, more-violent eruptions that are often greater in volume and have farther-reaching impacts.

On the other hand, less viscous magmas, such as basalt, flow more easily and tend to be erupted in more-frequent, gentle flows with variable volumes and travel distances. Lava flows can occur either from a volcano’s summit or flanks and are most commonly observed in less viscous

magma of basaltic and andesitic composition and relatively rare in rhyolite and dacite lavas. Lava tubes can result from lava flows as the surface of the flow cools and hardens first while the lava below the surface continues to flow. Basaltic lava flows can travel over 6 miles/hour on steep slopes, but generally proceed at less than 1 mile/hour on gentle sloping terrain. However, if these lava flows are confined in a channel or lava tube, they can have speeds over 20 miles/hour. Lava flows will destroy structures and objects in and near their path. Due to their slow speed, people can be usually evacuated prior to the destruction by the lava flow. Often, transportation routes and utilities are severed, and structures are buried. These flows can also create lakes and flooding from dammed streams. The extreme heat from lava flows will also cause objects near the flow path, not necessarily within the flow path, to melt or ignite.

## **Fumaroles**

Fumaroles are hot steam vents that allow volcanic gases to escape into the atmosphere. They can occur along cracks and fissures in the volcano, as well as the surface of lava flows and pyroclastic flow deposits. The vented gases include carbon monoxide (CO), carbon dioxide (CO<sub>2</sub>), hydrochloric acid (HCl), hydrogen fluoride (HF), hydrogen sulfide (H<sub>2</sub>S), sulfur dioxide (SO<sub>2</sub>), sulfur trioxide (SO<sub>3</sub>) and others. The volcanic gases that pose the greatest threat to humans, animals, and property are sulfur dioxide, carbon dioxide, and hydrogen fluoride. Concentration of gases around the vents and accumulation in low areas may cause asphyxiation. If water has contact with the gases and they become dissolved, the caustic water can damage vegetation and corrode metals.

## **Tephra**

Tephra (also known as ‘pyroclastics’ or ‘ash fallout’) collectively describes airborne volcanic particles, of any size, that have been extruded from a volcano. The smallest particles, volcanic ash and dust, are sand and silt-sized respectively. Lapilli are smaller than 2.5 inches and blocks/bombs are larger than 2.5 inches. The direction that tephra is carried following extrusion is largely determined by wind direction. Deposits of tephra consist of angular particles that are often loose, highly erodible and poorly-cemented when deposited at cool temperatures because they are typically deposited at cool temperatures. The thickness, strength, and degree of consolidation of tephra deposits can be highly variably. Depending on thickness and distribution, tephra can disrupt ground and air transportation; damage machinery, structures, and electronic equipment; and affect human health (especially respiratory health) at levels ranging from nuisance to severe problems. Fine tephra particles tend to have the farthest reaching impacts of volcanic eruptions as wind-blown ash can travel hundreds to thousands of miles away from the eruption site.

## **Pyroclastic Flows**

Pyroclastic flows are hot flows of ash, lapilli and bomb size particles, and gases from an explosive eruption (Figure 3-40). Pyroclastic flows are denser than air and as such, they travel close to the ground, much like avalanches, following valleys and can have speeds up to 450 miles/hour. The temperature within a pyroclastic flow can be up to 1500°F. Pyroclastic flows can be triggered by the collapse of a lava dome, collapse of an eruption column, or a

flank/directional blast from a volcano. Due to their immense heat and mobility, pyroclastic flows can cause destruction by direct impact, burning of vegetation and other objects, burying material, and triggering lahars from melting snow and ice. Ignimbrite and tuff deposits from pyroclastic flows are often welded together due to high temperatures within the flow. These deposits can be highly variable in strength, thickness, and degree of welding over relatively small distances.



**Figure 3-40** Photograph of pyroclastic flow traveling down the flanks of Mt. St Helens during the August 7, 1980 eruption, viewed from a vantage point 5 miles north of Mt. St. Helens on Johnston Ridge. (Image taken by Peter Lipman, public domain; accessed from: <https://www.usgs.gov/media/images/pyroclastic-flow-during-aug-7-1980-mount-st-helens-eruption>).

### **Mass Wasting associated with Active Volcanism**

Because of the pressure changes, heat, and lava/magma movements associated with active volcanism, volcanoes can trigger debris avalanches and lahars. Mass wasting that does not require a volcanic trigger, but is associated with volcanic materials, is discussed in Section 3.25.

Volcanic environments often produce large, oversteepened slopes that consist of weak or variable strength material. These conditions can result in debris avalanches and lahars, both of which are large, destructive mass wasting events. Debris avalanches are large, fast-moving masses of rock, soil, snow, and ice that travel down the flanks of a volcano. Lahars consist of mud, sand, gravel, and boulders mixed with large amounts of water. As a result, lahars tend to be more mobile and can travel farther from the material source. In the same way that landslides can mobilize into debris flows with incorporation of sufficient water, debris avalanches can mobilize into lahars if more water is incorporated, or if heat from the volcano melts snow and ice in the debris avalanche mass. Debris avalanches are frequently triggered by pressure from the magma chamber or ground movement from an eruption, while lahars are often triggered when

heat from an eruption melts snow and ice on the flanks of a volcano. Sedimentation from both lahars and debris avalanches can also affect river flow paths and accumulate in dams, creating potential for flooding and overtopping of dams.

### **Other Associated Events and Processes**

In addition to fumaroles, active volcanoes can be associated with a variety of geothermal activity (water heated at depth from proximity to high temperature magma and flowing to the surface), including hot springs, steam vents, and geysers. These can result in hot to boiling water being present at or near the surface. Geothermal waters can be dangerously hot and sometimes low pH, and also can contain high concentrations of dissolved minerals or toxic dissolved gases.

Volcanic eruptions can be accompanied by earthquakes, which reflect the movement of magma beneath the Earth's surface (see Section 3.23). The frequency and magnitude of the earthquakes can increase before an eruption, and have been used in volcano monitoring. Earthquakes have many effects including changes to drainage patterns, elevation changes, triggering landslides and lahars, and disruption of transportation corridors and utility lines.

Flooding can occur due to numerous active volcanic processes. Increased sedimentation from volcanic eruptions, such as tephra/ashfall, lahars, debris avalanches, and pyroclastic flows, can cause flooding by altering stream flow, clogging drainage networks, reducing infiltration, and filling of rivers and lakes, which can lead to increased water levels. In some cases, the increased water levels can lead to overtopping of both natural and artificial dams.

Tsunamis (see Section 3.25) are waves typically created by ocean floor earthquakes, submarine landslides, or submarine volcanic eruptions. Tsunamis can also occur in lakes during volcanic activity and can be triggered by volcanic earthquakes, underwater eruptions, and/or mass movements into a body of water. These waves can cause flooding and destruction great distances from their source.

### **SITE INVESTIGATION GOALS**

Because the majority of active volcanic hazards are difficult or impossible to mitigate due to their magnitude, extent, and/or temperature, the overall goals of site investigations in active volcanic areas are to: characterize the extent of volcanism; constrain likely ranges of hazard types, magnitudes (volumes of material), and frequencies; and evaluate the usefulness of early warning systems. This information will aid in evaluating acceptable levels of risk when designing engineering works. More specific goals include:

- a) Identify the geographic locations and extent of active volcanism on or in the vicinity of the site
- b) Obtain site and regional specific volcanic hazard maps, if available, from the USGS Volcano Hazards Program (2015)
- c) Obtain historical information on regional volcanic eruptions (timing, extent, and magnitude), and mass-wasting triggering events such as heavy rainfall and earthquakes



- d) Evaluate volcanic topography and assess inundation zones for flooding, lahars, pyroclastic flow, and lava flow surrounding and downstream from volcanoes
- e) Check for available early warning systems and monitor early warning system information throughout the project for safety

## **SITE INVESTIGATION ACTIONS**

### **Review of Existing Information**

Obtain and review existing volcanic hazard data for the site, including any local hazard assessments, hazard zonation maps, and geologic maps. Frequently, geologic maps and volcanic hazard maps can be obtained from the USGS. Also, topographic maps, aerial photos, media reports, and interviews can be sources of existing hazard information of the local area.

### **Aerial Photograph Study and Field Reconnaissance**

Current and historical aerial photography and satellite imagery should be obtained when available. This can include aerial/satellite images available from Google Earth or other internet or printed sources. Volcanic geometry and topography changes observed in the past, especially after high-energy events, can indicate the extent and types of hazards that are possible in a given area. In areas of oversteepened volcanoes, landslide features can often be identified from aerial photography, digital elevation models, or LiDAR point clouds. Drainage pathways and changes in those drainage pathways can also be observed from these data sources.

### **Volcanic Hazard Monitoring**

The USGS has developed a program that monitors active volcanic hazards in the U.S. and its territories. The USGS, and its five volcano observatories, are responsible for creating alerts for volcanic hazards. Discussion of the monitoring and warning system is beyond the scope of this guidebook, however, information on the monitoring system and current volcanic hazard levels can be accessed on the USGS Volcano Hazards Program website (USGS, 2015).

### **Volcanic Activity Hazard Alert System**

The USGS has an established Alert-Notification System for Volcanic Activity that monitors and disseminates information and/or warnings to the public about volcanic activity. The five USGS volcano observatories, in cooperation with State and university partners, are responsible for issuing volcanic activity warnings (USGS, 2006b; USGS, 2015). The appropriate Federal and State emergency management agencies are notified, who then provide information/warnings to government and public organizations.

### **Modeling**

Computer modeling is an effective way to estimate the extents and magnitudes of future eruption related hazards. A variety of models may be potentially applicable to active volcanic hazards (pyroclastic flows: Constantinescu et al., 2011; lahars: Schilling, 2014; tephra, pyroclastic flows,



lava flows, lahars, and edifice formation/failure: Deligne et al. 2017). Use of these models can help to identify areas of highest risk during volcanic activity, direct mitigation measures, and prioritize evacuations.

## **POSSIBLE MITIGATION ACTIONS**

The scope of the engineering project and proximity to active volcanic hazards will direct the design and implementation of mitigation actions. In areas of active volcanism, many hazards are difficult or impossible to mitigate due to uncertainties in predicting volcanic events and processes. However, monitoring of volcanic activity and modeling of volcanic events can help prepare a community by providing estimates of volcanic events. These estimates can be used within evacuation warning systems and operational-response planning for events. Options for mitigation may include:

- Avoidance
- Early warning systems, evacuation protocols, and emergency-response planning for local communities
- Preparing and updating volcanic hazard land use maps. Effective use of these maps (i.e. avoid high hazard areas) in planning new projects
- Preemptive closure of transportation routes within the volcanic hazard vicinity during eruptions
- In some cases, mitigating of lahars by installation of debris control structures
- Maintenance and inspection of structures affected by ash and debris
- Pumping and use of available water to cool and slow approaching lava flows

## **RECOMMENDED AND CITED REFERENCES**

Coombs, M. L., McGimsey, R. G., & Browne, B. L. 2008. Preliminary volcano-hazard assessment for Gareloi Volcano, Gareloi Island, Alaska. U.S. Geological Survey Scientific Investigations Report 2008-5159, 26 p.

Constantinescu, R. Thouret, J.-C., and Irimus, I.-A. 2011. Computer modeling as tool for volcanic hazards assessment: an example of pyroclastic flow modeling at El Misti volcano, Southern Peru. *Geographia Technica*. 14. 1-14.

Decker, R., and Decker, B. 1998. *Volcanoes* (3rd ed.). New York, New York: W.H. Freeman and Company, 321 p.

Deligne, N.I., Horspool, N., Canessa, S., Matcham, I., Williams, G.T., Wilson, G., and Wilson, T.M. 2017. Evaluating the impacts of volcanic eruptions using RiskScape. *Journal of Applied Volcanology*. 6, 18. <https://doi.org/10.1186/s13617-017-0069-2>

Goodman, R.E. 1993. *Engineering Geology: Rock in Engineering Construction*. New York, New York: John Wiley & Sons Inc., 412 p.

- Hoblitt, R. P., Miller, C. D., & Scott, W. E. 1987. Volcanic hazards with regard to siting nuclear-power plants in the Pacific Northwest: U.S. Geological Survey Open-File Report 87-297, 197 p.
- Hungr, O. 1995. A model for the runout analysis of rapid flow slides, debris flows, and avalanches. *Canadian Geotechnical Journal*, 32, 610-623.
- John, D. A., Sisson, T. W., Breit, G. N., Rye, R. O., & Vallance, J. W. 2008. Characteristics, extent and origin of hydrothermal alteration at Mount Rainier Volcano, Cascades Arc, USA: Implications for debris-flow hazards and mineral deposits. *Journal of Volcanology and Geothermal Research*, 175(3), 289-314. doi: 10.1016/j.jvolgeores.2008.04.004.
- Loughlin, S.C., Sparks, R. S. J., Brown, S.K., Jenkins, S.F., and Vye-Brown, C. 2015. *Global Volcanic Hazards and Risk*. Cambridge, United Kingdom: Cambridge University Press.
- Martí Molist, J. 2017. Assessing Volcanic Hazard: A Review. *Oxford Handbooks Online*. Available from: <https://www.oxfordhandbooks.com/view/10.1093/oxfordhb/9780190699420.001.0001/oxfordhb-9780190699420-e-32>.
- Papale, P. (ed.). 2015. *Volcanic Hazards, Risks and Disasters* Amsterdam: Elsevier, 2015.
- Scarpa, R. and Tilling, R.I. 1996. *Monitoring and Mitigation of Volcano Hazards*. Berlin, Heidelberg: Springer. 842 p.
- Schilling, S. P. 2014. Laharz\_py: GIS tools for automated mapping of lahar inundation hazard zones: U.S. Geological Survey Open-File Report 2014-1073, 82 p.
- Tilling, R. I. 1989. Volcanic Hazards and their Mitigation: Progress and Problems. *Reviews of Geophysics*, 27(2), 237-269. doi: 10.1029/RG027i002p00237.
- United States Geological Survey (USGS). 2006a. U.S. Geological Survey's National Volcano Early Warning System (NVEWS). USGS Fact Sheet 2006-3142.
- United States Geological Survey (USGS). 2006b. U.S. Geological Survey's Alert-Notification System for Volcanic Activity. USGS Fact Sheet 2006-3139.
- United States Geological Survey (USGS). 2015. Volcano Hazards Program. <http://volcanoes.usgs.gov/>.
- Vallance, J. W. 1999. Lahars. In H. Sigurdsson, B. F. Houghton, S. R. McNutt, H. Rymer, & J. Stix (Eds.), *Encyclopedia of Volcanoes*, pp. 601-616. New York, New York: Academic Press.
- Wilcox, R. E. 1959. Some effects of recent volcanic ash falls with especial reference to Alaska. Washington D.C: U.S. Government Printing Office. U.S. Geological Survey Bulletin 1028-N, 74 p.

## 3.25 VOLCANIC TERRAIN HAZARDS

### THREATS POSED TO ENGINEERED WORKS

- Highly variable rock and soil properties due to variable materials, depositional environments, and weathering
- Slope instability, including landslides, rockfall, debris flows, etc. (Sections 3.19, 3.20, and 3.26)
- High erosion rates in soils, unwelded tuffs, and ash deposits
- Soil development related hazards:
  - Expansive soils from weathering of volcanic rocks to smectite clays (see Section 3.1)
  - Acidic soils
  - High erosion rates in weak soils, unwelded tuffs, and ash deposits
- Voids and caverns

### FIELD INDICATORS OF VOLCANIC TERRAIN HAZARDS

- Landforms such as volcanic cones, craters, and lava tubes
- Volcanic deposits including ash, lava flows, and lahar deposits
- Extrusive rock types such as rhyolite, andesite, basalt, and tuff
- Ancient volcanic or island arc setting
- Columnar jointing of rock masses
- Hydrothermal alteration of rock

### OCCURRENCE OF VOLCANIC TERRAIN HAZARDS

Volcanic terrain hazards occur in regions where volcanic materials are exposed at or near the surface. This includes both regions with active volcanism (eruptions or geothermal activity) and in those where previously active volcanoes are now considered dormant or extinct/inactive. Many areas of the U.S. have experienced volcanism in the past and have deposits of volcanic materials, but do not have any currently active volcanoes. As a result, volcanic terrain hazards are likely to occur much more widely than active volcanic hazards. This chapter focuses on hazards that are related to volcanic materials and landforms but are not initiated by active volcanism (which are covered in Section 3.24).

To evaluate whether volcanic terrain hazards are likely at a given site, bedrock geologic maps should be consulted to check for deposits of volcanic origin, and surface field indicators listed above should be identified.

### MECHANISMS OF VOLCANIC TERRAIN HAZARDS

The mechanisms of volcanic terrain hazards are similar to many hazards found in other areas with non-volcanic materials. Steep slopes and weak materials contribute to unstable slopes. Jointed rocks can be susceptible to rockfall. Pre-existing voids and piping in volcanic soils and weak deposits can lead to the formation of collapse features and additional voids. Weathered or altered rocks and soil can have problematically low strengths and be vulnerable to erosion.

## **ENGINEERING CHARACTERISTICS OF VOLCANIC TERRAIN HAZARDS**

The following descriptions of engineering characteristics of volcanic deposits and related hazards have been adapted and summarized largely from Goodman (1993) and the USGS Volcano Hazards Program (USGS, 2015). Ollala et al. (2010) provide additional details on volcanic rock mechanics.

### **Volcanic Materials**

#### ***Extrusive Rocks***

Volcanic eruptions form deposits of new materials, including extrusive igneous rocks (e.g. basalt, andesite, dacite, rhyolite) and volcaniclastic rocks (ash deposits, tephra, pyroclastic flows). Intrusive igneous rocks can be associated with volcanic activity, as the same heat and pressure that causes eruptions at the surface can drive emplacement of intrusions into the host rock. Extrusive rocks can be highly variable in strength and degree of fracturing, depending on the composition of the magma. Volcaniclastic rocks tend to be weaker than extrusive igneous rocks because their deposition typically follows some amount of transport of the material, which can cool rock fragments and make deposits more granular.

The heat from volcanic eruptions or associated intrusions can cause metamorphism of host or country rock (older rock surrounding or underlying new material) or alteration of soil. These processes can reduce the strength of the surrounding materials and cause development of potentially hazardous materials, such as asbestos in rock (metamorphosing of ultramafic rocks into serpentinite, which can contain asbestos minerals; see Section 3.28) or expansive clays in rock or soil (see Section 3.1).

Volcanic depositional processes are highly variable spatially and temporally, resulting in deposits (both extrusive and volcaniclastic) that can vary in rock type, thickness, degree of lithification, degree of weathering, and engineering properties, such as strength, permeability, erodibility, jointing/fracturing, and compressibility. In addition to variable engineering properties, volcanic deposits can contain voids from lava tubes or erosion and pseudokarst in weak materials after deposition. (related karst topics are discussed in Sections 3.5 and 3.6). Voids and pseudokarst can affect drainage and water flow paths, potentially contributing to water contamination and piping. The high degree of variability associated with volcanic materials requires careful characterization to mitigate engineering problems. Columnar jointing, which is a common feature of cooled lava and pyroclastic flows, can create rock masses with relatively high rockfall activity.

#### ***Weathering***

Many minerals in volcanic rock are unstable and vulnerable to weathering. Magnesium and iron rich volcanic rocks, such as basalt, as well as volcanic glass and feldspars, weather to highly expansive and plastic clays. The extent of weathering and soil formation is a function of time exposed to weathering processes, climate, rock type, and joint spacing to allow water infiltration.

Expansive clays can result in differential settlement or heaving beneath engineered structures (see Section 3.1).

### ***Hydrothermal Alteration***

Besides weathering processes, in volcanic environments hydrothermal alteration of rock can occur. Hydrothermal alteration refers to chemical changes in host rock of any type caused by exposure to heat and fluids from magmatism. The resulting chemical reactions from this exposure change the composition and structure of the rock. Typically, this process weakens the host rock, introducing weak clay minerals and new joints. As a result, hydrothermally altered rock can contribute to erosion and mass wasting issues more than unaltered rock.

### ***Volcanic soils***

In volcanic terrain, additional hazards can result from development of volcanic soils. Soils developed from extrusive rocks or tephra can be acidic, potentially capable of corroding metal or concrete, or contain expansive clays (Delmelle et al. 2015). In addition, volcanic soils can be poorly consolidated and easily erodible, especially on volcano flanks.

### **Slope Instability**

As in non-volcanic environments, slope instability is primarily driven by slope conditions, material strengths, and water conditions (Sections 3.19 and 3.20). Volcanic terrain often contains steep slopes and weak or heterogenous materials. In some areas, vegetation can be slow to colonize volcanic deposits, contributing to large amounts of runoff. Weathering of oversteepened volcanic materials can quickly decrease material strengths, contributing to slope instability.

Like other kinds of mass-wasting, debris avalanches, lahars, and pyroclastic flows from volcanos can produce large deposits of irregular material with hummocky ground and steep relief at the distal and lateral edges of the deposit. Since debris avalanches begin as landslides, and lahars are volcanic debris flows, their deposition characteristics and associated hazards are similar to other non-volcanic landslides and debris flows (Sections 3.19 and 3.20).

### **Confined Aquifers**

The process of deposition in volcanic terrain is discontinuous and can result in layers of differing material types with variable extent. As a result, aquifers in volcanic terrain can also be highly discontinuous and confined. Confined aquifers encountered in volcanic terrain during engineering construction and excavation can potentially produce large water inflows to excavations. Confined aquifers can pose threats to tunneling, pier foundations, and roadway cuts, due to water inflow and decreased material shear strength.

## **SITE INVESTIGATION GOALS**

- a) Characterize the locations and extent of volcanic materials

- b) Investigate the lithologies present on site, considering, at least, horizontal and vertical variability, weak materials properties, asbestos-bearing rocks, expansive clays, and acidic soils
- c) Evaluate volcanic topography, erosion rates, and potential for mass-wasting. Investigate probable types of mass wasting and potential scales of events
- d) Investigate lava flows and weak materials for lava tubes and collapse voids

## **SITE INVESTIGATION ACTIONS**

Detailed site investigations are recommended in areas with volcanic deposits due to the potentially extreme lateral and vertical variability of materials.

### **Review of Existing Information**

Obtain and review existing geologic, surficial, and volcanic hazard maps for the site. The information collected in the preliminary review will guide what tests should be conducted and what material properties should be characterized. Reports from projects and scientific studies in the area can help to constrain expected ranges of material properties.

Current and historical aerial photography and satellite imagery (available for Google Earth or other internet or printed sources), and topographic maps/data (digital elevation models, or LiDAR point clouds) should be obtained when available. These data sources can be used to locate existing landslides, drainages pathways, and oversteepened slopes.

### **Field Reconnaissance**

Field reconnaissance should be completed to evaluate potentially unstable slopes. Rock slopes should be characterized according to one or more rock mass classification systems (Section 3.20).

Sampling and monitoring may be required to characterize active landslides (Section 3.19).

### **Borings**

The purpose of borings is to characterize subsurface materials and conditions and to obtain soil and rock samples. Of particular interest in volcanic terrain are material strengths, groundwater conditions (piezometers can be installed in boreholes), and the heterogeneity of materials. Volcanic terrain may require a larger number of borings than other areas in order to adequately characterize the heterogeneity of soil and rock. Detailed boring logs should be created for all borings. Borings can be combined with shallower subsurface investigation methods, such as geophysics, test pits, and trenching where more lateral detail is required.

### **Sampling**

Samples should be taken of all soil and rock units encountered. Sampling should be careful and thorough in order to characterize all the relevant units. Laboratory strength tests generally

require undisturbed samples, but this varies from test to test. If clay units are encountered, undisturbed samples are required for swell testing (Section 3.1). For potentially acidic soils, disturbed samples are sufficient, and some basic tests, such as pH, can be performed in the field.

## **Geophysical Methods**

Geophysical methods provide another way to characterize horizontal and vertical variability in volcanic materials. Gravity and magnetic methods work well with mafic rocks, such as basalt, because basalt is dense and tends to contain magnetite. Seismic reflection and refraction can be used to evaluate depths of weathering profiles and material contrasts. Additionally, ground penetrating radar and resistivity can be used to detect subsurface voids such as those created by lava tubes. Geophysical methods should be used in combination with borings, which help to calibrate geophysical interpretations.

## **Laboratory Testing**

Laboratory testing should be completed to evaluate the mechanical properties of the materials on-site. This may include tests for strength, grain size distributions, swell potential/swell capacity, collapse potential, and chemical characteristics.

Swelling potential/ swell capacity (see Section 3.1)

Collapse potential/general susceptibility to hydrocompaction (see Section 3.9)

- Alkali-silica reaction of rock material and cement (ASTM C 1293)
- Sodium sulfate soundness of rock (ASTM C88/ASTM D5240)
- pH of soils (ASTM D4972)

## **POSSIBLE MITIGATION ACTIONS**

- Avoidance
- Amend acidic soils with neutralizing agents
- Protect metal components from acidic soils using coatings or cathodic protection (Bushman and Chaker, 2005, Bradford, 2000)
- Grouting or back-filling of voids and fractures
- Remove or amend expansive soils (Section 3.1)
- Rockfall stabilization or protection (Section 3.19)
- Landslide monitoring or stabilization (Section 3.20)
- Install debris flow protection structures (Section 3.20)
- Surface treatments and structures to reduce or prevent erosion

## **RECOMMENDED AND CITED REFERENCES**

Bushman, J.B., and Chaker, V. 2005. Chapter 65: Highways, Tunnels, and Bridges. In: *Corrosion Tests and Standards: Application and Interpretation* (2<sup>nd</sup> ed.), R. Baboian, ed. ASTM International. pp. 706-715.

Bradford, S.A. (2000). *The practical handbook of corrosion control in soils*. Canada: CASTI Publishing Inc.

Chester D.K., Duncan A.M. (2018) Volcanic Environments. In: Bobrowsky P.T., Marker B. (eds) *Encyclopedia of Engineering Geology*. Encyclopedia of Earth Sciences Series. Springer, Cham

Decker, R., and Decker, B. 1998. *Volcanoes* (3rd ed.). New York, New York: W.H. Freeman and Company, 321 p.

Delmelle, P., Opfergelt, S., Cornelis, J.-P. and Ping, C.L. 2015). Chapter 72 – Volcanic Soils. In: *The Encyclopedia of Volcanoes*, H. Sigurdsson, B. Houghton, McNutt, S., R. Hazel, and J. Stix eds. Amsterdam: Academic Press.

Erguler Z.A. (2018) Hydrothermal Alteration. In: Bobrowsky P.T., Marker B. (eds) *Encyclopedia of Engineering Geology*. Encyclopedia of Earth Sciences Series. Springer, Cham

Escalante, E. 2005. Chapter 14: Soils (testing). In: *Corrosion Tests and Standards: Application and Interpretation* (2<sup>nd</sup> ed.), R. Baboian, ed. ASTM International. pp.181-186.

John, D. A., Sisson, T. W., Breit, G. N., Rye, R. O., & Vallance, J. W. 2008. Characteristics, extent and origin of hydrothermal alteration at Mount Rainier Volcano, Cascades Arc, USA: Implications for debris-flow hazards and mineral deposits. *Journal of Volcanology and Geothermal Research*, 175(3), 289-314. doi: 10.1016/j.jvolgeores.2008.04.004.

Marker B.R. (2018) Alkali-Silica Reaction. In: Bobrowsky P.T., Marker B. (eds) *Encyclopedia of Engineering Geology*. Encyclopedia of Earth Sciences Series. Springer, Cham

Menéndez, M.M and González-Gallego, J. 2010. Rock mass classification schemes in volcanic rocks. In Olalla, C., Hernández, L.E., Rodríguez-Losada, J.A., Perucho, Á. and GonzálezGallego, J. (Eds.), *Volcanic Rock Mechanics: Rock mechanics and geo-engineering in volcanic environments*, pp. 67- 72. Boca Raton, Florida: CRC Press/Balkema.

Neild, J. O'Flaherty, P., Hedley, P., Underwood, R., Johnston, D., and Christenson, B., and Brown, P. 1999. Impacts of a Volcanic Eruption on Agriculture and Forestry in New Zealand. New Zealand Ministry of Agriculture and Forestry, MAF Policy technical paper 99/2. <https://www.mpi.govt.nz/dmsdocument/138/direct>

Olalla, C., Hernández, L.E., Rodríguez-Losada, J.A., Perucho, Á. And GonzálezGallego, J. (Eds.). 2010. *Volcanic Rock Mechanics: Rock mechanics and geo-engineering in volcanic environments*, Boca Raton, Florida: CRC Press/Balkema, 355p.

Tilling, R. I. 1989. Volcanic Hazards and their Mitigation: Progress and Problems. *Reviews of Geophysics*, 27(2), 237-269. doi: 10.1029/RG027i002p00237.



Vallance, J. W. 1999. Lahars. *In* H. Sigurdsson, B. F. Houghton, S. R. McNutt, H. Rymer, & J. Stix (Eds.), *Encyclopedia of Volcanoes*, pp. 601-616. New York, New York: Academic Press.

Veleva, L. 2005. Chapter 32: Soils. *In: Corrosion Tests and Standards: Application and Interpretation* (2nd ed.), R. Baboian, ed. ASTM International, pp. 387-404.

Wada, K. 1987. Minerals formed and mineral formation from volcanic ash by weathering. *Chemical Geology*, 60(1-4), 17-28. doi: 10.1016/0009-2541(87)90106-9.

Wilcox, R. E. 1959. Some effects of recent volcanic ash falls with especial reference to Alaska. Washington D.C: U.S. Government Printing Office. U.S. Geological Survey Bulletin 1028-N, 74 p.

## 3.26 SURFACE WATER HAZARDS

### THREATS POSED TO ENGINEERED WORKS

- Inundation of structures from flooding
- Damage to structure foundations from erosion or scour
- Blockage of transportation routes from the accumulation of water, deposited debris or from washouts along the route
- Liquefaction of fluvial or alluvial deposits
- Settlement in collapsible soils

### FIELD INDICATORS OF SURFACE WATER HAZARDS

- Areas of low topography adjacent to bodies of water, rivers, and drainage channels
- Fine to coarse deposits of soil, rock and other debris at the base of or within a drainage channel
- Cone or fan-shaped topography at the base of a mountain range.
- Unconsolidated surface materials (especially tabular fine-grained sediments or layered silts, sands, and gravels)
- Hard, dried-out soils (often associated with hot, arid climates)
- Large areas of exposed rock within a drainage network (especially shales and other easily-eroded rock)
- Areas below heavy snowpack
- Woody debris along or within channels
- Steep slopes near a body of water or drainage

### OCCURRENCE OF SURFACE WATER HAZARDS

Surface water hazards are related to the interaction between moving water and the land. As a category, surface water encompasses all of the water in lakes, rivers, streams, ice, and snow, but excludes ocean water (coastal geohazards are addressed in Section 3.27). For the purpose of hazard investigations, rainfall and runoff are also considered surface water. Surface water hazards are present in every state and territory in the United States. The most common surface water hazard in the United States is flooding (NOAA, 2020a). Debris flow hazards are most common in the western U.S. due to the mountainous terrain. However, debris flows have also occurred on the east coast and in the Appalachian Mountains.

### Important Geomorphic Features Associated with Surface Water Processes

Stream/river channels, alluvial fans, dry channels/washes, flood plains, gullies and rills, canyons, braided stream sediment deposits, etc.

## **MECHANISMS OF SURFACE WATER HAZARDS**

### **Flooding**

Flooding can occur for a variety of reasons and in many different environments. Below are descriptions, adapted and summarized largely from NOAA (2020a), for a few types of flooding commonly experienced around the U.S. Flooding along coastlines is addressed in Section 3.27.

#### ***River Flooding***

River flooding occurs when water levels rise and water overtops the river banks or channel boundaries flooding into adjacent low-lying areas. This type of flooding can be caused by heavy rainfall, rapid snowmelt, or the failure of natural dams such as landslide dams, debris jams, or ice jams. River flooding can also be caused by failure of man-made dams and structures. Flooding can also occur from water backing up on tributary streams that cannot drain because the trunk river is at a high flood elevation.

The severity of flooding can be classified as minor, moderate, or major flooding. The class depends on the water level, areal extent of flooding and the level of impacts to roads and other structures.

#### ***Flash Flooding***

Flash flooding is the result of a rapid rise in water level within a stream channel and other low-lying areas, including those that may have been previously dry. Small streams of water or dry channels can become raging rivers in a relatively short period of time. This type of flood is commonly associated with intense rainfall and often develops within 6 hours of the rainfall event. Flash flooding can impact areas well away from the source, in areas where it has not rained. Flash flooding is especially common in the western U.S., where mountainous terrain promotes rapid runoff and accumulation of water in drainage channels. Extensive rocky areas, clay soils, and hardened soils in hot and arid environments (known as dry wash) exacerbate flash flooding as infiltration of water into the subsurface is significantly reduced by these materials, resulting in substantial runoff.

#### ***Snowmelt Flooding***

Snowmelt flooding occurs when the primary input of water into the system is from the melting of snow, and the volume of water from the melting snow exceeds the capacity of rivers, streams and lakes. Excess runoff from melting snow that can lead to flooding is also driven by high soil moisture content, where high soil moisture levels created by rain in the fall lead to a decrease in storage capacity of the soil during the melting season in the spring. Areas in the U.S. most susceptible to this type of flooding are the states in the northern part of the country and mountainous regions such as the Cascade, Sierra Nevada, Rocky and Appalachian Mountains. Large quantities of water can be stored in snowpack until warmer temperatures begin the melting process. The thickness of snow cover can also impact the severity of snowmelt flooding since a deeper snowpack means there is more water available for snowmelt.

Rain-on-snow events, where rain falls with snow still on the ground can greatly contribute to flooding because of the extra amount of water and the snow melt that occurs during these events. Rain-on-snow events are considered one of the most significant flood hazards in the western U.S. (McCabe et al., 2007)

### ***Post-Wildfire Flooding***

Areas within and downstream of recent wildfire burn areas are at an increased risk for flooding due to denudation of previously vegetated or forested slopes and changes in soil infiltration properties in response to wildfire. See Section 3.29 for a full description.

### ***Ice/Debris Jams and Landslide Dams***

Ice and debris jams form when ice or debris accumulates at an obstruction in a river, stream or creek. Water can build up behind these features and flood areas upstream. Downstream locations may also experience flooding if ice or debris jams are breached catastrophically. Ice jams are most common in the northern portions of the U.S., including Alaska, and often form during the winter or spring. Problems associated with ice jams are generally resolved as the ice melts. Debris jams can form any time of year and may require special strategies to remove.

Landslide dams form when a slope failure adjacent to a river, creek or stream deposits material into a drainage restricting the flow of water. Sufficient blockage can lead to a buildup of water behind the landslide deposit flooding areas upstream. In some cases, slow erosion of the landslide dam will result in the lowering of the water level behind the dam relieving flooding upstream and preventing flooding downstream. However, flooding downstream can occur if the dam fails catastrophically. Landslide displacement into a body of water can produce large waves, which can flood the shoreline of the water body. In smaller bodies of water, displacement of water by the landslide mass may temporarily or permanently increase water levels resulting in flooding of low-lying, adjacent areas.

### **Erosion**

The movement of surface water can cause erosion of the material under the flow of water. The amount of erosion largely depends on the amount of energy of the flowing water and the type of material over which the water is passing. Therefore, higher energy events such as flooding can cause more severe and rapid erosion. While erosion by surface water is most prominent in soils (especially unconsolidated soils), erosion can also occur in rock, especially weaker or heavily fractured rocks such as shales. Erosion can be caused by runoff from rainfall or snow melt, or by the movement of water in rivers, creeks and streams. Overland flow can result in the formation of rills and gullies that can undercut structures and cause damage to roadways.

Erosion along river, creek and stream channels is one of the most significant hazards to structures along these features. Scour and slope instability resulting in landslides are the most common types of erosion along channels (see Sections 3.19 - 3.21). Additionally, river channels shift laterally (migrate) across their flood plains over time, and flood events can cause more rapid

changes in channel morphology and location. While erosion can affect all areas along river banks, cut banks (the outside bank of a bend in a river) are most strongly affected because they experience the highest water flow velocities. Structures and roads built on or near cut banks are especially susceptible to undercutting from erosion. Erosion can also occur within channels during high energy events, such as flooding, and can cause scour around bridge foundation elements located in or on the sides of the channel. Scour is localized downward erosion of the streambed caused by the abrasiveness of sediments in the water flowing around an obstruction in a channel. It is one of the leading causes of bridge damage and failure.

## **Debris Flows**

A debris flow (sometimes referred to as a mudslide or mudflow) is a mass of predominantly coarse-grained material that flows down a hillside as a viscous fluid at speeds typically around 10 mph, but can exceed 35 mph (Highland et al., 2004) and they have been observed traveling at speeds up to 100 mph (CGS, 2020). Debris flows can vary in consistency from watery mud to thicker mud choked with boulders and other debris, and capable of carrying trees, cars, pushing houses from their foundations, and washing out bridges. Burial of structures can occur in low-gradient areas where deposition of debris flow material occurs. For these reasons, debris flows can cause significant destruction to features in their paths.

Debris flows can be initiated by rapid snowmelt, but are more commonly associated with intense rainfall events that impact hilly terrain. Under some conditions, debris flow initiation can occur during high intensity storms that last as little as 30 minutes (Kean et al., 2011). Debris flows can originate as shallow landslides that liquefy to create a flow, or they can be caused by surface runoff that coalesces into a debris flow through the entrainment of channel bed and bank sediment. As the debris flow travels down a channel, it increases in volume with the addition of more water, soil, rocks, sand, and other debris. Because debris flows are an alluvial process, locations with the highest debris flow hazard include steep alluvial areas such as canyon bottoms, stream channels, and areas near the outlet of these features such as alluvial and debris fans.

Across the U.S., debris flow hazards can be exacerbated by wildfires (Section 3.29). Wildfires remove vegetation, cause changes in soil properties, and increase sediment supplies to drainages. These, in turn, increase the likelihood of runoff generated debris flow formation in the years following a wildfire. It has been observed that debris flows are most common during immediate post-wildfire storms, and decrease in frequency as the rainy season progresses (Wells, 1987). The effects of the landscape alteration from wildfire are suggested to last up to three or four years (Santi et al., 2013), but can persist beyond that depending on varying environmental and climatic conditions.

## **Liquefiable/Collapsible Soils**

Deposits of fluvial or alluvial origin are often loose and saturated and may be susceptible to liquefaction due to ground shaking. Alluvial and debris flow deposits may host collapsible soils. For more information on liquefaction, see Section 3.23, and for more information on collapsible soils, see Section 3.9.

## **SITE INVESTIGATION GOALS**

- a) Determine if the site is located within a declared flood plain of a river, creek or other drainage channel through the review of state and federal hazard maps (generally for larger waterways)
- b) Determine if the site is located within a geologic flood plain by identifying landforms associated with flooding, such as terraces, or backwater or overbank (fine-grained) deposits
- c) Identify other indicators of flooding such as surface water erosion, and debris flows.
- d) Estimate the frequency, magnitude, and types of flooding that could occur at the site (through the review of reports of recent or historical events)
- e) Map location of slopes within a drainage susceptible to shallow landslides that may initiate debris flows as well as potential runout paths
- f) Map areas of current and potential slope instability near bodies of water or drainages that could become blocked by a landslide
- g) Determine the type and extent of subsurface units (through borings and review of geologic maps)
- h) Determine the scour potential (adapted from FEMA, 2012)
  - Estimate the maximum allowable scour
  - Estimate the anticipated scour depth and the depth of any underlying strata that stop scour action

## **SITE INVESTIGATION ACTIONS**

### **Review of Existing Information**

- Flood hazard information and maps are available online from the FEMA Map Service Center (2020).
- Historical flooding and debris flow records for the region can be found in traditional news sources as well as in scientific and government publications.
- Subsurface and surficial geologic data is available from the USGS (2020b) and soil data is available from the U.S. Department of Agriculture, Natural Resources Conservation Service (NRCS) Web Soil Survey (USDA, 2019).
- Many rivers and streams across the U.S. are monitored with stream gages. This information can be used to track water levels and flow velocities as well as determine historical and recent maximums and minimums of these parameters. This information can be found at the state level or from the United States Geological Survey (USGS, 2020c).
- Climate and meteorological data is useful for gathering information regarding weather events at the site that may be capable of producing flooding, erosion, or debris flow. This data is available at NOAA's National Centers for Environmental Information (NOAA, 2014).
- Topographic information is available from the USGS (2020b) and LiDAR data from the United States Interagency Elevation Inventory run by NOAA's Office for Coastal Management (NOAA, 2020b).

## **Aerial/Satellite Photograph Study and Field Reconnaissance**

Topographic data and images, including historical aerial/satellite photographs (from Google Earth or other internet or commercial sources), and bare-earth LiDAR data, should be reviewed, when possible, for any site to evaluate floodplain extents, channel migration for rivers and streams and erosion history. Additionally, the location of debris flows within or near a site can be noted, as their paths or deposits can, in some cases, be observed remotely.

## **Borings**

The purpose of subsurface borings is to evaluate the depth and extent of various deposits associated with surface water processes. This is especially important in the design of bridge structures. Borings can also help identify the thickness and depth of soils susceptible to collapse or liquefaction. The number, depth and spacing of boreholes depends on the footprint of proposed works.

## **Sampling**

Sampling may be required for laboratory tests involving the erosion of soils, liquefaction, or collapsible soils. Specific sampling techniques for tests involving collapsible or liquefiable soils are located in Sections 3.9 and 3.23, respectively.

## **Laboratory Tests**

For specific laboratory tests pertaining to collapse potential and liquefaction, see Sections 3.9 and 3.23.

Below are a few typical tests to investigate soil and rock erodibility

- Erodibility of Soil by the Jet Index Method (ASTM D5852)
- Slake Durability (mechanism of erosion in rock, especially shales) (ASTM D4644)

There are currently no standardized tests to estimate the susceptibility of rock to erosion due to flowing water. One of the most common non-laboratory methods for estimating erodibility of rock is the Erodibility Index Method (Annandale, 1995; Annandale, 2006), which uses an erodibility index and stream power estimates to calculate erosion potential. For more information on this method and the appropriate equations and charts, refer to USBR (2019).

## **POSSIBLE MITIGATION ACTIONS**

- Avoidance of flood prone areas or locations susceptible to erosion from surface water flow
- Relocate structures away from eroding river banks
- Armor river, stream, and creek channels with vegetation, rip-rap, engineered logjams, etc., to prevent bank erosion
- Implement site specific scour countermeasures

- Construct new levees, remove unnecessary levees, set back current levees, and restore flood plains to promote natural channel migration, increase flood water distribution and energy dissipation, decrease the potential for scour along levees, and increase the flow containment capacity of the levee system
- Surface erosion mitigation, such as reseeded, mulching, straw wattles, log erosion barriers, flood barriers, and water bars
- Debris flow mitigation, including debris deflectors, sediment barriers, debris retention basins, and debris racks
- Reinforce culverts and bridge structures to prevent flooding due to blockage from debris flow material
- Add engineered channels to convey excess surface water through sensitive areas such as residential neighborhoods
- Mitigation actions related to collapsible soils and liquefaction can be found in Sections 3.9 and 3.23

## RECOMMENDED AND CITED REFERENCES

Annandale, G.W. 1995. Erodibility. *Journal of Hydraulic Research*, 33(4), pp. 471-494.

Annandale, G.W. 2006. Scour Technology: Mechanics and Engineering Practice. New York: McGraw-Hill, 420 p.

Colorado Geological Survey (CGS). 2020. Debris and Mud Flows [online].  
<https://coloradogeologicalsurvey.org/hazards/debris-flows/>.

Federal Emergency Management Agency (FEMA). 2012. Chapter 4: Determination of Hazards. *In: Engineering Principles and Practices for Retrofitting Flood-Prone Residential Structures*, 3<sup>rd</sup> ed. FEMA P-259. <https://www.fema.gov/media-library/assets/documents/3001>.

Federal Emergency Management Agency (FEMA). 2020. Flood Map Service Center.  
<https://msc.fema.gov/portal/home>.

Highland, L.M., Stephenson, E.D., Christian, S.B., and Brown, H.M. 2004. Debris Flow Hazards in the United States. United States Geological Survey, Fact Sheet 176-97.  
<https://pubs.usgs.gov/fs/fs-176-97/fs-176-97.pdf>.

InciWeb, Incident Information System. 2020. Current Incidents. <http://inciweb.nwcg.gov/>.

Kean, J. W., Staley, D. M., & Cannon, S. H. 2011. In Situ Measurements of Post-Fire Debris Flows in Southern California: Comparisons of the Timing and Magnitude of 24 Debris-Flow Events with Rainfall and Soil Moisture Conditions. *Journal of Geophysical Research*, Vol. 116 (F04019), doi: 10.1029/2011jf002005.

Matthias, J., and Hungr, O. 2005. *Debris-Flow Hazards and Related Phenomena*. 1st ed. Berlin, Heidelberg: Springer Berlin Heidelberg.



McCabe, G.J., Clark, M.P., and Hay, L.E. 2007. Rain on Snow Events in the Western United States. *Bulletin of the American Meteorological Society*, 88(3), 319-328. <https://doi.org/10.1175/BAMS-88-3-319>.

Melville, B.W., and Coleman, S.E. 2000. Bridge Scour. Highlands Ranch, CO: Water Resources Publications, 550 p.

National Oceanic and Atmospheric Administration (NOAA). 2014. National Centers for Environmental Information. <https://www.ncei.noaa.gov/>

National Oceanic and Atmospheric Administration (NOAA). 2020a. National Weather Service: Flood Related Hazards. <https://www.weather.gov/safety/flood-hazards#:~:text=Flash%20floods%20generally%20develop%20within,where%20heavy%20rain%20initially%20fell.>

National Oceanic and Atmospheric Administration (NOAA). 2020b. United States Interagency Elevation Inventory, National Ocean Service, Office of Coastal Management. <https://coast.noaa.gov/inventory/>

Santi, P., Cannon, S., and DeGraff, J. 2013. Wildfire and Landscape Change. *In*: John F. Shroder (Ed.) *Treatise on Geomorphology*, Vol. 13, pp. 262-287. San Diego: Academic Press.

Wells, W. G. 1987. The Effects of Fire on the Generation of Debris Flows in Southern California. *Geological Society of America, Reviews in Engineering Geology*. Vol. 7, pp. 105-114. doi: 10.1130/REG7-p105.

United States Bureau of Reclamation (USBR). 2019. Chapter D-1: Erosion of Rock and Soil. Best Practices in Dam and Levee Safety Risk Analysis. Section D: Embankments and Foundations. <https://www.usbr.gov/ssle/damsafety/risk/BestPractices/Chapters/D1-ErosionOfRockAndSoil.pdf>.

United States Department of Agriculture (USDA). 2019. Natural Resources Conservation Service (NRCS) Web Soil Survey. <http://websoilsurvey.sc.egov.usda.gov/App/HomePage.htm>.

United States Department of Transportation (USDOT), Federal Highway Administration (FHWA). 2012. Evaluating Scour at Bridges, 5<sup>th</sup> ed. Publication No. FHWA-HIF-12-003, Hydraulics Engineering Circular No. 18. <https://www.fhwa.dot.gov/engineering/hydraulics/pubs/hif12003.pdf>.

United States Geological Survey (USGS). 2020a. Landslide Hazards Program, Hazards. <http://landslides.usgs.gov/hazards/>.

United States Geological Survey (USGS). 2020b. The National Geologic Map Database. [http://ngmdb.usgs.gov/ngmdb/ngmdb\\_home.html](http://ngmdb.usgs.gov/ngmdb/ngmdb_home.html).

United States Geological Survey (USGS). 2020c. USGS Water Resources, Current Water Data for the Nation. <https://waterdata.usgs.gov/nwis/rt>

## 3.27 COASTAL HAZARDS

### THREATS POSED TO ENGINEERED WORKS

- Decrease of material shear strength due to shallow water table and flooding
- Damage to structures due to flooding (storm surge, rising seawater level, tsunamis, scour) and dynamic beach processes (erosion, sedimentation, and lateral movement)
- Production of saline, sulfate, and acid sulfate soils (see Sections 3.13, 3.15, and 3.16, respectively) that could lead to:
  - Corrosion of concrete and metals
  - Long term settlement
  - Volume expansion of soils when mixed with lime
- Slope instability (along coastal bluffs) (see Sections 3.19 – 3.21)
  - Formation of unstable features such as voids and sea arches
- Failure of sensitive marine clays in uplifted areas (see Section 3.11)
- Liquefaction of coastal deposits (see Section 3.23)

### FIELD INDICATORS OF COASTAL HAZARDS

- Geographic location (elevation, proximity to coastline)
- Presence of brackish water in well systems
- Unconsolidated materials (soil) that may be associated with typical coastal features such as river deltas, sand dunes, and barrier islands, or weakly-lithified versions of the same
- Interbedded weak and strong strata in the coastal environment
- Coastal bluffs, sea caves, and sea arches

### OCCURRENCE OF COASTAL HAZARDS

Coastal hazards exist along the United States ocean coastline including Alaska, Hawaii, Puerto Rico, the Pacific Coast, the Gulf Coast, the Atlantic Coast, and other US island territories, and along the freshwater coastline of the Great Lakes region. Coastal hazards are present in locations varying from directly adjacent to the coast to further inland depending on the specific hazard and general characteristics of the site. For example, flooding due to storm surge or tsunamis may impact areas farther from the coast if lowland coastal areas extend inland. The Federal Emergency Management Agency (FEMA) has created maps illustrating the flood hazard across the U.S. (FEMA, 2020).

Coastal environments involve complex interaction of forces that lead to dynamic beach processes that are influenced by geologic, tectonic, climatic, biologic, and anthropogenic factors. The transient nature of the geomorphic features created by dynamic beach processes means that site conditions and the proximity to certain hazards can change during the life of an engineered structure.

## **MECHANISMS OF COASTAL HAZARDS**

The following descriptions of coastal processes have been adapted and summarized largely from Thurman and Trujillo (1999) and the U.S. Army Corps of Engineers (USACE, 2004).

Coastal geomorphology is primarily controlled by the soil and rock found along coastal areas. Variable soil and rock material properties, and degree of consolidation and cementation determine their susceptibility to erosion and dissolution from coastal processes. Materials with a higher degree of consolidation and stronger cementation generally have a greater ability to resist weathering and erosion. As a result, coastal processes more strongly affect unconsolidated soil and weak rock. Along coasts with unconsolidated materials, both erosion (of existing deposits) and deposition (e.g. river delta, sand dune, and barrier island formation) can occur simultaneously. During storm events, unconsolidated coasts are more susceptible to rapid changes in coastline topography. Regions of coastline where consolidated rocks are exposed tend to be dominated by erosional processes.

### **Wave Action**

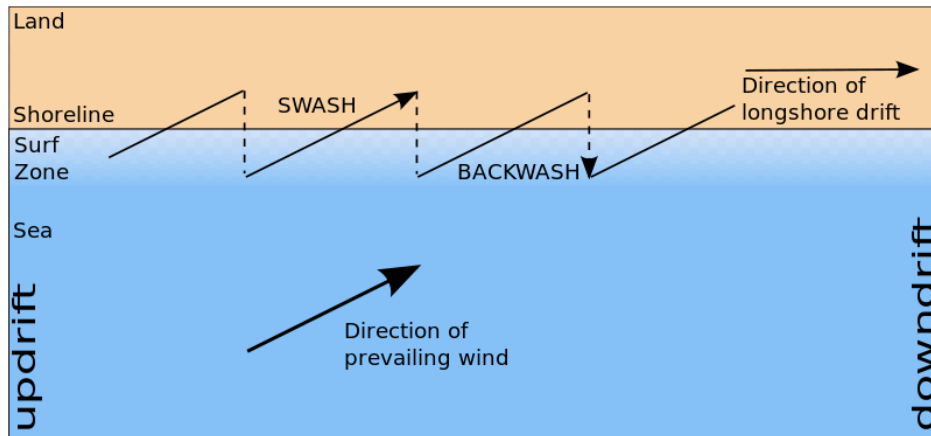
#### *Waves*

Waves in the ocean transmit energy through the water. When the wave reaches the shore, that energy is converted to a load applied to coastal materials. The interaction of wave energy and coastline materials is generally the most important process governing the morphology of the coastline.

Wave processes can both concentrate energy, eroding headland features, and spread energy, depositing material in bays and coves. The energy associated with waves changes seasonally and is reflected in variations in beach topography throughout the year. During the winter months, generally higher energy waves scour the coastline, and may expose bedrock near the shore. During the summer months, lower energy waves deposit additional sediment and rebuild beaches along the coast.

#### *Littoral Drift*

Littoral drift (also known as longshore drift) is the process of sediment transport downdrift (along the coastline in the direction of the prevailing winds) by the repeated swash and backwash of waves (Figure 3-41). The majority of the sediment transported along the coast by littoral drift is supplied by rivers and eroded headland areas. This process creates sedimentation and erosion hazards, as littoral drift tends to deposit material on the updrift sides of obstacles and erode material on the downdrift sides.



**Figure 3-41** Diagram of littoral drift process and terminology. From Wikimedia Commons (2014).

### *Tsunamis*

A tsunami is a long period wave that can be caused by displacement of the ocean floor during earthquakes, submarine volcanic eruptions, or landslides (submarine or subaerial). These waves can travel across oceans and cause flooding and severe erosion at great distances from their sources, both along the coast and inland along river channels and in low-lying areas. Coasts in tectonically active areas are especially vulnerable to tsunamis that result from earthquakes along nearby plate boundaries. The entrainment of debris by tsunamis can further exacerbate damage to structures. The mechanics of tsunami wave motion, erosion, and potential deposition are very similar to those of normal waves. However, because of their increased amplitude, energy, and degree of inundation, tsunamis tend to be more damaging and produce noticeable coastal changes more quickly.

### **Tides**

A tide is the periodic rise and fall of surface water levels due to gravitational and centripetal forces between the earth, moon, and sun. For the Great Lakes region, tides are primarily influenced by atmospheric pressure changes and wind (USACE, 2004). Tidal action scours and transports sediment, creating a dynamic shoreline, and can lead to increased flood and erosion hazards. Fluctuations in water levels result in lateral movement of shoreline and thus influence the location and distribution of wave processes.

The degree of water level fluctuation is dependent on the local coastal geometry and results in a varying tidal range. This variation in tide range must be considered for construction design in tidal areas. Tidal action affects both the outermost coastline and some more inland areas near river mouths. In river mouths, waves called tidal bores can propagate along the river channel.

### **Sea Level Rise and Submerging of the Coast**

There are numerous causes for sea level rise, including coastal subsidence and melting polar ice that adds water to the ocean. The primary effect of sea level rise is increased flooding and

erosion (described in detail online at the National Oceanic and Atmospheric Administration (NOAA) National Ocean Service (2014a) website). An extension of potential flood zones and areas of permanent flooding or submergence may be required as sea level rises and inundates more land (FEMA, 2013a).

## **Coastal Erosion and Deposition**

Coastal environments contain a balance between sediment input and output. Sediment can be input to coastal systems from river deltas, volcanoes, or wind transport, while wave action and movement of ocean water tend to remove sediment, pulling eroded material farther out to sea. Different coastal features occur under different sediment flux conditions:

- *Coastal Bluffs*: Coastal bluffs are erosional coastal features and are usually found in areas of tectonic uplift, for example, along the Pacific Coast. Bluffs are over-steepened and can be composed of consolidated material interbedded with weak units. Wave erosion of headlands at the bases of bluffs causes undercutting of slope material and can contribute to slope instability (see Sections 3.19 - 3.21). Wave microseismic energy and vibration can cause slope instability by causing fatigue failure of bluff materials (Adams et al., 2005; Brain et al., 2014). Bluff retreat (retrogression of bluffs inland due to slope failures) can be a hazard to nearby structures on top of the bluff as well as below the bluff where eroded material is deposited. Bluff retreat can also occur during rain events. This type of retreat occurs when bluff materials become saturated resulting in a decrease in material strength due to an influx of water and subsequent increase in pore pressures and decrease in effective stress (see Section 3.20).
- *River Deltas*: River deltas are depositional coastal features that form where the sediment influx from a river is greater than the sediment outflux caused by coastal erosion. Sediment deposited in these environments is unconsolidated and saturated. Due to their low elevation above sea level, river delta areas are subject to flooding and liquefaction hazards.
- *Sand Dunes*: Sand dunes are depositional coastal features. Growth of sand dunes is dependent on sediment supply from backshore beaches and wind transport. Dune stability varies depending on vegetation cover; humid climates have more vegetation cover and typically more stable dunes. Dunes provide natural protection for inland terrain as they create a barrier from coastal processes such as waves, tides, and storm surge associated with high-energy events. Unstable dunes are transient and can move depending on the terrain and wind conditions. Dune environments can be subject to erosion and sedimentation issues, in addition to foundation issues associated with loose sands.

## **Hazardous Materials in Coastal Environments**

Coastal environments can result in formation of potentially hazardous soil materials, such as:

- *Saline Soils*: Deposition in a saline, coastal environment can result in deposition of saline soils (Section 3.13). The saline component can cause corrosion of metals and long-term settlement.

- *Sulfate and acid sulfate soils*: Deposition in an organic-rich, saturated coastal environment can result in the formation of sulfate (Section 3.15) and acid sulfate (Section 3.16) soils. The sulfate component can cause corrosion of concrete and volume expansion of soils when mixed with lime.
- *Sensitive Clays*: Failure of sensitive marine clays (see Section 3.11) is possible in uplifted areas and can be triggered by saturation from rainfall or disturbance from construction projects.
- *Liquefaction*: In tectonically active areas, shallow, saturated deposits can be susceptible to liquefaction due to ground motion caused by earthquakes (see Section 3.23).

### **Anthropogenic Impacts**

Man-made coastal features such as groins, jetties, seawalls, and bulkheads often affect coastal processes (USACE, 2004).

- Groins are installed perpendicular to the shore to trap littoral drift and reduce erosion along the beach. However, installment of groins can cause erosion of beaches or headlands downdrift.
- Jetties are structures that are built perpendicular to the shore and are designed to confine tidal or river flow. They are also used to protect harbors from storm waves. Jetties can also cause accumulation of sediment updrift and erosion downdrift.
- Seawalls and bulkheads are structures built parallel to the shore. They are designed to reduce erosion and undercutting of bluffs. However, wave reflection and resultant turbulence can scour the beach and potentially undermine the wall. In addition, if groundwater drainage on the landward side of the seawall is poor, slope instability and bluff failure can occur due to increased pore water pressure.

### **Coastal Hazards and High-Energy Events**

Because of high-energy storms and tsunamis, coastlines can change dramatically in the course of a single event. Intense storms can promote erosion, slope instability (both through precipitation and through increased wave action against coastal bluffs), and inland flooding. Tsunamis can inundate large portions of coastal lowlands very quickly, potentially resulting in local deposition and erosion of sediment and debris.

### **SITE INVESTIGATION GOALS**

The following site investigation guidelines have been adapted and condensed largely from USACE (2004).

- a) Identify the geographic location of the site as a coastal area and characterize the geology and coastal topography
- b) Obtain site-specific erosion and flood hazard information (FEMA, 2013a; FEMA, 2013b; NOAA, 2014a)
- c) Obtain historical information on erosion and high-energy event effects (considering the high-energy event magnitude)

- d) Identify existing and suspended unstable slope processes. Consider the potential for reactivation due to coastal processes or high-energy events
- e) Perform slope stability analyses to constrain design (see Sections 3.19, 3.20, 3.21)
- f) Investigate the rock and soil types present at the site (through a review of existing information, site reconnaissance, field testing, sampling, and laboratory methods)
- g) Characterize the source of energy for erosion, the process of sediment movement and deposition, and the fluctuations in coastal topography

## **SITE INVESTIGATION ACTIONS**

### **Review of Existing Information**

Obtain and review available coastal data. Literature sources include data from coastal universities, sources such as local government records and newspapers, and national government records. Government sources such as the USGS, NOAA, U.S. Department of Agriculture, FEMA, and the USACE provide valuable resources including historical data and computer modeling programs. Relevant data types include:

- Climate and meteorological data (NOAA, 2013b; NOAA, 2014c)
- Historical wave data (NOAA, 2014c; USACE, 2010)
- Information on historic data, trends, and predictions of tides, currents, and seawater level (NOAA, 2013a)
- Geologic and sediment data (USGS, 2020)
- Soil survey data (USDA, 2013)
- Topographic maps (USGS, 2020) and/or LiDAR data (NOAA, 2014b)
- Bathymetric survey maps to characterize submarine topography (NOAA, 2014c)
- Information on flood hazards and construction in coastal zones (FEMA, 2013b)
- Flood zone descriptions (FEMA, 2013c) and flood hazard maps (FEMA, 2013a)

### **Aerial Photograph Study and Field Reconnaissance**

Current and historical aerial photography and satellite imagery from Google Earth or other internet or printed sources, and LiDAR topography data, should be obtained and reviewed when available. These data are useful for identifying coastal changes in the past, areas that might be vulnerable to ongoing or future erosion and slope instability, and regions that could be inundated by flooding.

### **Monitoring**

The purpose of monitoring is to obtain more-detailed, site-specific information regarding on-site coastal processes. Erosion rates of bluffs can be monitored using repeat photographs, terrestrial or aerial photogrammetry, or terrestrial or aerial LiDAR

Wave action and tidal behavior should be monitored to evaluate the expected range of water heights, wave directions, and wave power to use as design parameters. Directional and non-

directional wave gauges can obtain detailed wave measurements to evaluate typical wave power and heights. Tide gauges and tidal observations can be used to identify water level changes.

## **Field Testing**

The purpose of field testing is to gain detailed geologic, stratigraphic, and groundwater information in areas where heterogeneous coastal deposits may present hazards such as liquefaction of clean saturated sands or sensitive clays. Surficial and bedrock deposits should be mapped in detail. Geophysical methods, such as seismic refraction and resistivity, should be used in combination with core sampling to accurately characterize the subsurface lithology and locate the water table.

If bathymetric surveys are required (such as for deep bridge foundations), echo sounders are commonly used to measure offshore depths. Bathymetric survey maps are also available online from NOAA's National Centers for Environmental Information (NOAA, 2014c). Sub-bottom seismic devices use seismic waves to penetrate through the seafloor and reveal information on the lithology of underlying rock and soil units.

## **Modeling**

Modeling of coastal erosion and sedimentation processes can provide information about current site conditions and help to identify hazards present and the effects of mitigation efforts. Mathematical modeling can be used to simulate coastal processes and allows for hazard characterization to be completed in a reasonable time frame and with the ability to create multiple scenarios and outcomes. Waves, tides, and currents can be modeled to investigate the effect on near-shore sediment flow processes (Bird, 2008; USACE, 2010). Additionally, liquefaction can be modeled in those areas where liquefaction susceptible deposits are suspected to exist.

## **Borings**

The purpose of borings in coastal environments is to provide core samples. Laboratory tests of the samples can provide information of historical coastal processes, energy of coastal processes, and indicate periods of deposition and erosion. The types of material in coastal sediments reflect sediment source areas, transport pathways, and depositional or erosional energy. Large particles, like gravel, require more energy for transport. Smaller particles, such as clay and silt, can travel farther distances and are deposited in lower energy environments. This information can provide insight into potential hazards present as well as be incorporated into mathematical modeling as described above.

## **Sampling**

Samples should be collected in the field to evaluate hazardous soil properties (saline, sulfate, acid sulfate, sensitive clays) and material strengths (for slope stability calculations). Undisturbed samples are required for many strength and consolidation/collapse tests. However, chemical tests can typically be completed using disturbed samples.



## Laboratory Testing

Seasonal changes cause variations in sediment type along coastlines. Therefore, laboratory testing should be conducted on samples obtained during both the winter and summer seasons to reflect the impact of seasonality on the soil characteristics. Evaluation of coastal hazards can require a variety of tests. Selected tests relevant to corrosion are listed below. Other relevant tests are discussed in other sections.

Strength tests for slope stability (see Section 3.19 – 3.21)

Tests for liquefiable soils (see Section 3.23)

Tests for consolidation and collapsible soils (see Section 3.9)

Tests for sensitive soils (see Section 3.11)

Corrosion tests:

- Sodium sulfate (AASHTO T 290)
- pH of Soils for Corrosion Testing (AASHTO T 289; ASTM G51)
- Resistivity (AASHTO T 288)

## POSSIBLE MITIGATION ACTIONS

Coastal environments involve complex processes where even “stable” beaches are dynamic. Design and construction in coastal environments must comply with local and national laws, codes, and procedures. Options for mitigation might include:

- Avoidance: move structures away from flood areas, beyond the FEMA 100-year flooding limit and wave zones if possible
- If construction must occur within areas subject to inundation by the 100-year flood event (FEMA Zone A), or areas closest to the shoreline that are subject to storm wave action, high-velocity flow and erosion from the 100-year flood event (FEMA Zone V) (FEMA, 2010; FEMA, 2013a; FEMA, 2013b; FEMA, 2014) the following are suggested:
  - Elevate structures above the base flood elevation (BFE)
  - Install deep foundations
  - Incorporate appropriate design measures to prevent flotation, collapse, and lateral movement of structures during flood event design
- Choose historical high-energy floods and storms as design events.
- Choose culvert fill materials and fill methods carefully, and confine fills with filter fabrics to prevent fill washout
- In areas of bluffs and undermining: move structures away from coastal cliffs, use slope stabilization and protection techniques (e.g., soil nail wall with shotcrete facing), and control erosion (e.g., riprap or wave breaks) (see Sections 3.19 – 3.21).
- Remove, amend, or saturate sulfate and acid sulfate soils (Sections 3.15 and 3.16)
- Amend corrosive soils with neutralizing agents, or remove

- Avoid, remove, or chemically treat sensitive soils if present on the site (see Section 3.11)
- Avoid, design for, or treat liquefiable soils if present on the site (see Section 3.23)

## RECOMMENDED AND CITED REFERENCES

Adams, P.N., Storlazzi, C.D. and Anderson, R.S. 2005. Nearshore Wave-Induced Cyclical Flexing of Sea Cliffs. *Journal of Geophysical Research*, 110(F02002).

Brain, M.J., Rosser, N.J., Norman, E.C. and Petley, D.N. 2014. Are Microseismic Ground Displacements a Significant Geomorphic Agent? *Geomorphology*, 207: 161 - 173.

Bird, E. 2008. *Coastal Geomorphology: An Introduction*. 2<sup>nd</sup> Ed. John Wiley and Sons Ltd., West Sussex, England.

Eckert, J. and Callender, G. 1987. *Geotechnical Engineering in the Coastal Zone*. Instruction Report CERC-87-1, U.S. Army Engineer Waterways Experiment Station, Vicksburg, MS.

Federal Emergency Management Agency (FEMA). 2010. Home Builder's Guide to Coastal Construction, Technical Fact Sheet Series, FEMA P-499. [http://www.fema.gov/media-library-data/20130726-1538-20490-2983/fema499web\\_2.pdf](http://www.fema.gov/media-library-data/20130726-1538-20490-2983/fema499web_2.pdf).

Federal Emergency Management Agency (FEMA). 2013a. Flood Map Service Center. <https://msc.fema.gov/portal/home>

Federal Emergency Management Agency (FEMA). 2013b. Hazard Mitigation Planning. <https://www.fema.gov/hazard-mitigation-planning>

Federal Emergency Management Agency (FEMA). 2013c. Protecting our Communities, Flood Zones. <http://www.fema.gov/floodplain-management/flood-zones>.

Federal Emergency Management Agency (FEMA). 2014. Coastal Mapping Basics. <http://www.region2coastal.com/coastal-mapping-basics>.

Johnsson, M. 2003. Establishing Development Setbacks from Coastal Bluffs. In: O. Magoon (Editor), *California and the World Ocean*, 2002.

Komar, P.D. 1998. *Beach Processes and Sedimentation*. Second Edition. Prentice Hall Inc., Upper Saddle River, New Jersey.

Luettrich, R. (ed.). 2018. Coastal Hazards Related to Storm Surge. *Journal of Marine Science and Engineering*, Special Issue reprint. Multidisciplinary Digital Publishing Institute. 258 p.

National Oceanic and Atmospheric Administration (NOAA). 2013a. National Ocean Service, Center for Operational Oceanographic Products and Services. <http://oceanservice.noaa.gov/programs/coops/>.

National Oceanic and Atmospheric Administration (NOAA). 2013b. National Weather Service, National Hurricane Center. <http://www.nhc.noaa.gov/>.

National Oceanic and Atmospheric Administration (NOAA). 2014a. National Ocean Service. <http://oceanservice.noaa.gov/>.

National Oceanic and Atmospheric Administration (NOAA). 2014b. Office for Coastal Management. Digital Coast. <https://coast.noaa.gov/digitalcoast/data/coastallidar.html>

National Oceanic and Atmospheric Administration (NOAA). 2014c. National Centers for Environmental Information. <https://www.ncei.noaa.gov/>

Scripps Institution of Oceanography, University of California San Diego. 2003. Coastal Morphology Group, Beaches. [http://coastalchange.ucsd.edu/st3\\_basics/beaches.html](http://coastalchange.ucsd.edu/st3_basics/beaches.html).

Stockdon, H.F., Doran, K.J., Thompson, D.M., Sopkin, K.L., and Plant, N.G. 2013. National Assessment of Hurricane-Induced Coastal Erosion Hazards: Southeast Atlantic Coast: U.S. Geological Survey Open-File Report 2013-1130, 28 p.

Thurman, H.V. and Trujillo, A.P. 1999. Essentials of Oceanography. 6<sup>th</sup> Edition. Prentice Hall Inc., Upper Saddle River, New Jersey.

Tokuyama, H. 2012. Federal Highway Administration (FHWA). Learning from Japan's Ordeal. Public Roads, Vol. 75, No. 6. Publication No. FHWA-HRT-12-004.

United States Army Corps of Engineers (USACE). 2004. Coastal Geology, Manual EM 1110-2-1810. University Press of the Pacific, Honolulu, Hawaii.

United States Army Corps of Engineers (USACE). 2010. Coastal and Hydraulics Laboratory, Wave Research Tools, Wave Information Studies Model. [http://wis.usace.army.mil/wis\\_documentation.html](http://wis.usace.army.mil/wis_documentation.html) and model available online at <http://wis.usace.army.mil/>.

United States Department of Agriculture (USDA). 2013. Natural Resources Conservation Service (NRCS) Web Soil Survey. <http://websoilsurvey.sc.egov.usda.gov/App/HomePage.htm>.

United States Geological Survey (USGS). 2013a. Assessing Hazards Along our Nation's Coasts. USGS Fact Sheet 2013-3007.

United States Geological Survey (USGS). 2014a. Coastal and Marine Geology Program. <https://www.usgs.gov/natural-hazards/coastal-marine-hazards-and-resources>

United States Geological Survey (USGS). 2014b. Earthquake Hazards Program. <https://www.usgs.gov/natural-hazards/earthquake-hazards>

United States Geological Survey (USGS). 2020. The National Geologic Map Database. [http://ngmdb.usgs.gov/ngmdb/ngmdb\\_home.html](http://ngmdb.usgs.gov/ngmdb/ngmdb_home.html).

Williams, S.J., Dodd, K., and Gohn, K.K. 1997. Coasts in Crisis; online version. U.S. Geological Survey Circular 1075. <http://pubs.usgs.gov/circ/c1075/>.

### **3.28 NATURALLY OCCURRING ASBESTOS (NOA)**

#### **THREATS POSED TO ENGINEERED WORKS**

Naturally occurring asbestos (NOA) primarily presents an inhalation health risk to humans, potentially affecting both workers on-site and residents in the vicinity of an NOA release. NOA typically does not cause direct damage to engineered works, but does present serious health hazards when disturbed (i.e., when NOA crystals become airborne), including:

- Cancer: NOA is classified as a known human carcinogen (IARC, 2012)
- Various other lung diseases associated with inhalation of asbestos fibers, such as asbestosis and mesothelioma. In some cases, even low-level exposures can cause severe illness
- Airborne NOA fibers caused by dust generated by excavations, construction, and maintenance activities on or in NOA-containing soil, rock, or alluvial deposits

#### **FIELD INDICATORS OF NOA**

- Bundles or veins of visible, fibrous asbestos crystals in rock (generally, NOA can only be confirmed by laboratory microscope analysis)
- Serpentine rocks or other mafic or ultramafic rock outcrops on site or upstream of the site
- Sometimes, geologic maps will indicate formations known to contain NOA
- Site history of fills derived from ultramafic or mafic deposits
- Site history of dumping of asbestos-containing construction materials

#### **OCCURRENCE OF NOA**

Asbestiform (having the crystal habit of an asbestos mineral) minerals are formed in serpentinites and by the metamorphic alteration of several other rock types, including ultramafic rocks (such as dunite, peridotite, pyroxenite, and amphibolite), mafic rocks (such as basalt and gabbro), dolostones, iron formations, carbonatites, talc deposits, and alkalic intrusions. These minerals can in some cases be visibly identified as asbestiform in hand samples depending on the mineral concentration and crystal habit (crystal shape). However, asbestiform minerals are often only visible at the microscopic scale and may be present in a material without being visible in hand specimen.

NOA occurs in at least 34 of the US states. In addition, former asbestos mines, mill sites, and other known processing areas have been mapped across the US (Van Gosen, 2006a, 2006b, 2007b, 2008, 2010; Van Gosen and Clinkenbeard, 2011 – all available from: USGS, 2014).

#### **MECHANISM OF NOA**

Asbestos refers to a group of silicate minerals that form long, thin, fibrous crystals. Asbestiform minerals have been widely used for a variety of industrial applications because they are resistant to heat and corrosion. The six most commonly regulated asbestiform minerals are divided into

two groups: serpentine asbestos, including chrysotile, and amphibole asbestos, including amosite, crocidolite, tremolite, anthophyllite, and actinolite. Chrysotile is the most commonly used asbestiform mineral for industrial applications. While only these six are typically regulated, other asbestiform minerals pose similar health hazards, and should be treated accordingly (NIOSH, 2011).

Asbestiform minerals are hazardous because they form very small (microscopic) crystals, which, when disturbed, can become airborne and can be inhaled. In the lungs, asbestos fibers can cause physical scarring of lung tissue and decreased lung capacity, as well as increased risk of lung cancer.

While there are existing regulations and health and safety guidance for managing asbestos in buildings and at industrial sites, there is little national guidance for NOA in rock and soil. The Association of Environmental and Engineering Geologists NOA EMP Commission is actively working on new testing guidance, preparing improved safety guidelines, and promoting better regulation of NOA (<http://noa-emp.info/>).

## **SITE INVESTIGATION GOALS**

- a) Identify the presence of NOA in bedrock and natural soils, on-site and in the vicinity of the site
- b) Evaluate the history of the site and identify artificial fills that may contain asbestos
- c) Characterize the concentration, distribution, and extent of asbestos containing material
- d) Prepare a mitigation plan (compliant with OSHA standards) to implement during site development

## **SITE INVESTIGATION ACTIONS**

### **Sampling**

In order to characterize the NOA distribution across a site, samples should be collected according to a predesigned plan. This can be either: sampling at regular intervals across the site and with depth, or taking initial samples at a sparse interval across the site and targeting later samples to locations with higher NOA concentrations. Sample locations should be accurately recorded in order to map NOA concentrations across the site. Samples can be somewhat disturbed (i.e. grab samples), but must be of sufficient quality for microscope identification of NOA particles. In addition, any disturbance of NOA containing material can potentially release asbestos particles into the air, so sampling teams should be equipped with proper PPE, including respirators.

### **Laboratory Testing**

Because asbestiform minerals are often identifiable only at the microscopic scale, the presence of asbestos must be evaluated using laboratory techniques. The following tests identify asbestos and provide an estimate of the asbestos concentration.

- Standard Test Method for Determination of Asbestos in Soil (ASTM D7521)
- Asbestos Content in Serpentine Aggregate (soil or rock) (CARB 435)
- Polarized Light Microscopy of Asbestos (Crane, 1995)
- Asbestos in Bulk Building Material (EPA 600/R-93/116)

Chrysotile can also often be identified in association with high concentrations (greater than California EPA allowable levels in non-hazardous landfill waste) of nickel and chromium via the California Waste Extraction Test (WET) (State of California Code of Regulations, Title 22; see California Regional Water Quality Control Board, Central Valley Region, 1986).

### **Interpretation of Laboratory Results**

The results from the laboratory tests and/or rock thin section analysis will indicate whether there is a need for NOA avoidance or mitigation. If development proceeds (including site investigation), OSHA standards and regulations must be met for handling hazardous NOA-containing material, including, but not limited to, monitoring, protective equipment, containment, and waste removal. US Federal asbestos safety regulations are contained in 29 Code of Federal Regulations (CFR) 1926.1101. Sites in some states may be subject to additional or more stringent state asbestos safety regulations.

### **POSSIBLE MITIGATION ACTIONS**

- Avoid disturbance
- Dust control during development and post development
  - Speed limits on site access roads
  - Wetting of soil during exposure and during hauling, grading, and excavating
  - Roadway wet sweeping
  - Cover soil stockpiles
- Implement perimeter airborne NOA monitoring during construction
- Cap exposed NOA with soils that are free of NOA. The thickness of a soil cap is dependent on future potential depth of disturbance
- Carefully document NOA analysis and mitigation efforts. Clearly communicate the locations of NOA containing material and of mitigative caps/structures to avoid later disturbance of NOA containing material

### **RECOMMENDED AND CITED REFERENCES**

Cahill, E. 2020. Sampling, Analysis, and Risk Assessment for Asbestos and Other Mineral Fibers in Soil. *Environmental and Engineering Geoscience*, 26 (1): pp. 121–127.

California Air Resources Board. 1991. Determination of Asbestos Content in Serpentine Aggregate. CARB Method 435, Sacramento, CA.

California Department of Transportation (Caltrans). 2020. Contaminants and Waste – Naturally Occurring Asbestos (NOA). <https://dot.ca.gov/programs/environmental-analysis/hazardous-waste/contaminants-waste/noa>.

California Regional Water Quality Control Board, Central Valley Region. 1986 (updated 1989). The Designated Level Methodology for Waste Classification and Cleanup Level Determination. Available from: [https://www.waterboards.ca.gov/centralvalley/plans\\_policies/guidance/dlm.pdf](https://www.waterboards.ca.gov/centralvalley/plans_policies/guidance/dlm.pdf)

Crane, D.T. 1992 (1995). Polarized Light Microscopy of Asbestos. Occupational Safety and Health Administration Analytical Methods Manual, Method ID-191. Salt Lake City, Utah.

International Agency for Research on Cancer (IARC). 2012. Asbestos (Chrysotile, Amosite, Crocidolite, Tremolite, Actinolite, Anthophyllite). *In* Arsenic, Metals, Fibres, and Dusts. A Review of Human Carcinogens. IARC Monographs on the Evaluation of Carcinogenic Risks to Humans. Volume 100C. Pages 219-309. Lyon, France, distributed by the World Health Organization. Available from: <http://monographs.iarc.fr/>

Lee, R.J., Strohmeier, B.R., Bunker, K.L., Van Orden, D.R. 2008. Naturally Occurring Asbestos-A Recurring Public Policy Challenge. *Journal of Hazardous Materials*. Volume 153, No. 1-2, pp.1-21.

McCloskey, T.F. 2005. Mitigation Practices for NOA. *In* Geological Society of America, Cordilleran Section, 101<sup>st</sup> annual meeting. Volume 37, No. 4, pp. 55.

National Institute of Occupational Safety and Health (NIOSH). 2011. Asbestos Fibers and Other Elongate Mineral Particles: State of the Science and Roadmap for Research : Current Intelligence Bulletin 62, Publication No. 2011-159, 174 p.

Perkins, R.L., Harvey, B.W. 1993. Method for the Determination of Asbestos in Bulk Building Materials. U.S. Environmental Protection Agency, EPA 600/R-93/116. Washington, DC.

United States Geological Survey (USGS). 2014. Minerals Information: Asbestos Statistics and Information. <https://www.usgs.gov/centers/nmic/asbestos-statistics-and-information>

Van Gosen, B.S., 2006a, Reported Historic Asbestos Mines, Historic Asbestos Prospects, and Natural Asbestos Occurrences in the Eastern United States: U.S. Geological Survey Open-File Report 2005-1189, 1 pl.

Van Gosen, B.S., 2006b, Reported historic asbestos prospects and natural asbestos occurrences in the Central United States: U.S. Geological Survey Open-File Report 2006-1211, 1 pl.

Van Gosen, B.S. 2007a. The Geology of Asbestos in the United States and its Practical Applications. *Environmental and Engineering Geoscience*. Volume XIII, No. 1, pp. 55-68.

Van Gosen, B.S., 2007b, Reported Historic Asbestos Mines, Historic Asbestos Prospects, and Natural Asbestos Occurrences in the Rocky Mountain States of the United States (Colorado, Idaho, Montana, New Mexico, and Wyoming): U.S. Geological Survey Open-File Report 2007-1182, 1 pl.



Van Gosen, B.S., 2008, Reported Historic Asbestos Mines, Historic Asbestos Prospects, and Natural Asbestos Occurrences in the Southwestern United States (Arizona, Nevada, and Utah): U.S. Geological Survey Open-File Report 2008-1095, 1 pl.

Van Gosen, B.S., 2010, Reported historic asbestos mines, historic asbestos prospects, and other natural occurrences of asbestos in Oregon and Washington: U.S. Geological Survey Open-File Report 2010-1041, 1 pl.

Van Gosen, B.S., and Clinkenbeard, J.P., 2011, Reported historic asbestos mines, historic asbestos prospects, and other natural occurrences of asbestos in California: U.S. Geological Survey Open-File Report 2011-1188, 22 p., 1 pl.

## **3.29 WILDFIRE BURN AREA HAZARDS**

### **THREATS POSED TO ENGINEERED WORKS**

The rest of the hazards discussed in this manual are generally caused either by earth material properties or by the movement of an earth material (soil, rock, water, ice). This chapter seeks to address the important effect of wildfire on these other hazards. While wildfire can also pose a direct threat to engineered structures by burning, this chapter does not address this threat because fires can be caused by other sources as well. Wildfire burn areas tend to have the following effects on geologic hazards:

- Increased erosion from hillslopes coupled with increased sedimentation in low-lying areas, culverts, and channels
- Increased risk of flooding in and downstream of the burned area
- Increased risk of debris flows (see Section 3.26)
- Increased risk of unstable soil slopes (see Section 3.20)
- Increased risk of rockfall (see Section 3.19)
- Disruption or temporary closure of transportation (main roads and Forest Service access routes) and drainage routes

### **FIELD INDICATORS OF WILDFIRE BURN AREAS**

- History of wildfire in the area, with the most important impacts lasting three to four years, but with some effects persisting up to 30 years after the fire (Santi et al., 2013)
- Charred/blackened vegetation, rock, and soils
- Rill networks and raveled zones developed on hillsides

### **OCCURRENCE OF WILDFIRE BURN AREAS**

Wildfires can burn large areas of land throughout the United States, leaving behind terrain that can be significantly altered due to the effects of heat on rock and soil, and vegetation removal. They tend to occur more frequently, and with more severity, in areas with arid or semi-arid climates and in areas that are experiencing drought, while wetter areas tend to experience wildfire less frequently. Wildfires can occur both in forested areas and in areas dominated by grasses and shrubs, however the burn severity of fires tends to be greater in forest environments where more fuel is available.

Variations in climate on short and long-term scales also affect the frequency and severity of wildfire. Climate trends towards reduced winter precipitation, warmer spring weather, earlier spring snowmelt, and longer summer dry seasons contribute to higher frequency of large-scale and longer duration wildfires (Cannon and DeGraff, 2009). Regardless of the specific climate change processes, more frequent and more intense wildfires over larger areas have a significant impact on engineered structures and human life.

Because flooding, erosion, and debris flows are driven largely by precipitation, some portions of burned areas are more vulnerable than others to these hazards. Within the burned area, higher-

elevation channels and steep slopes are most vulnerable to increased erosion and debris flow initiation, while lower-elevation channels, low-lying areas, and valleys are most vulnerable to flooding, increased sedimentation, and increased deposition.

## **MECHANISMS OF WILDFIRE BURN AREAS**

### **Heat and Fire-Driven Changes to the Landscape**

Wildfires cause several significant changes to natural environments. Fire consumes vegetation, removing both surface cover and sometimes root structures as well. The removal of vegetation destabilizes soil, contributing to increased erosion and slope instability. The combustion of vegetation produces ash, which is deposited on top of the soil, creating a barrier between developed soils and the atmosphere. At the same time, the intense heat of wildfires promotes formation of a temporary, hydrophobic layer in the topmost few inches of soil. The combination of the ash layer on top of the soil and the hydrophobic soil layer reduces infiltration and increases runoff, while at the same time impeding reestablishment of vegetation. The increase in runoff contributes to erosion and increases the chance of debris flow initiation. Heat from wildfire can also directly weather boulders and bedrock, weakening intact rock and contributing to increased rockfall. In general, longer duration and high intensity wildfires result in greater effects on soil, vegetation, surface runoff, and erosion (Santi et al., 2013).

### **Effects on Relevant Geohazards**

Wildfire increases the risk of flooding, erosion, debris flows, and other forms of slope instability in the years following a wildfire. These increased risks tend to be greatest in the first rainy season after wildfire, but can last for several years to decades after the fire (Cannon and Gartner, 2005; Santi et al., 2013). In addition, wildfire effects on geohazards are dependent on the local severity of the fire. Wildfires do not typically burn the entire affected area at the same level of severity; rather, there tend to be zones of less severely burned or untouched land that can be completely surrounded by intensely burned areas. Wildfire has the greatest effect on geohazards where it is the most intense and the landscape is most altered by the fire.

The three most common post-wildfire geohazards, flooding, erosion, and debris flows, are all closely related to each other because water (primarily from precipitation) is involved in all three processes. Flooding typically causes erosion along water flow paths. Debris flows often are initiated by erosion resulting from overland flow of rainwater. And, debris flows are themselves an erosive process. Because of this, all three hazards must be considered together in evaluating hazard conditions in wildfire burn areas.

#### ***Increased flooding risk***

Removal of vegetation and formation of hydrophobic soil layers contribute to increased overland flow of precipitation. Overland flow is eventually captured in a drainage channels and flows downstream, combining with flow from other channels. The increased discharge from these channels can combine to cause localized flash flooding. As in other cases of flooding, post-

wildfire flooding can have significant impacts on engineered works, including bridges, culverts, embankments, and roadways (Section 3.26).

### ***Increased erosion***

Removal of vegetation and root structures by wildfire increases the rate and extent of erosional processes on hillslopes, including dry ravel and development of rill networks (Wells, 1987). In wildfire burn areas, erosion is primarily driven by precipitation, as runoff water entrains particles of soil and causes them to move down-hill. On steep slopes, dry ravel may be caused by gravity acting on weakened soils. Erosion by these mechanisms can remove topsoil on hillslopes and cause sediment to accumulate in downhill areas and channels. This increased sedimentation can affect engineered works, as well as potentially provide additional material in channels for debris flows (Section 3.26).

### ***Increased debris flow risk***

Debris flows are a hazard relevant to mountain areas whether or not the area has been burned by a wildfire (Section 3.26). Wildfire tends to increase the risk, extent, and magnitude of debris flows by:

- Removing vegetation that stabilizes sediment and intercepts precipitation, and therefore increasing the sediment supply and the potential for debris flow formation
- Increasing surface runoff due to ash layers and hydrophobic soils

A majority of post-wildfire debris flows are initiated by runoff water (typically from rainstorms but can also be sourced from snowmelt) entraining loose sediment, while non-wildfire-related debris flows show more instances of initiation by fluidizing of shallow landslides (Cannon and Gartner, 2005). Post-wildfire debris flows occur more frequently during storms that occur soon after the fire, and decrease in frequency as the rainy season progresses (Wells, 1987). The likelihood of a storm initiating a post wildfire debris flow has more to do with storm intensity than storm duration (Wells, 1987; Kean et al., 2011). In post-wildfire areas, debris flows can occur with little to no antecedent moisture content and with no specifically identified initiation source (Cannon et al., 2008). Because the areas burned by wildfires are sometimes very large, storms can potentially initiate many debris flows simultaneously across a geographic area, if the sediment supply and burn conditions are prone to debris flow initiation. As they progress downslope, debris flows can increase in volume due to entrainment of additional material (Santi et al., 2008).

Debris flows generally have a leading edge primarily composed of boulders, a central bulk moving as a viscous flow, and finally, a mud slurry as a tail. Damage to foundations and abutments is caused by impact and drag forces. Material entrainment results from buoyant forces and has been known to carry bridges and buildings downstream. Burial of structures by the debris flow is also possible, especially in areas of low elevation gradient where deposition is likely to occur (Cannon and DeGraff, 2009).

### ***Increased Rock and Soil Slope Instability***

Wildfires can also increase the risk of other kinds of slope instability, such as landslides (see Section 3.20) and rockfall (see Section 3.19) by removing stabilizing vegetation, decreasing interception of precipitation by tree leaves, decreasing the rate of drying of the soils on the slope through the uptake of water by vegetation, increasing surface runoff, and weathering intact rock.

### **SITE INVESTIGATION GOALS**

- a) Determine the extent of the wildfire burn area; evaluate burn severity and the relationship of severely burned areas to drainages and transportation routes
- b) Assess inundation zones for flooding and debris flow within and downstream of the burn area
- c) Consider expected degree of erosion from slopes
- d) Investigate potentially unstable slopes (see Sections 3.19 - 3.21)

### **SITE INVESTIGATION ACTIONS**

#### **Extent of Wildfire Burn Area and Severity of Burn**

Maps and satellite/aerial images of the area around the project site should be acquired to evaluate the extent and severity of wildfire burn. Severely burned areas are the most likely portions of the burned area to require erosion/debris flow/overland flow mitigation. Historical records should be consulted to check for wildfires that may not be obvious on satellite/aerial images. Wildfire burn area maps and/or perimeters are available on InciWeb (2020), and other federal, state, and local agency websites. Rapid Analysis of Vegetation (RAVG) data prepared by the US Forest Service maps the severity of burning across the wildfire burn area (USDA FS, 2020). If regional information is not available, then field mapping of wildfire extent and severity should be completed. Alternatively, hazard evaluations can be completed using the conservative assumption that the entire basin/vicinity is severely impacted by wildfire, though this assumption will likely increase mitigation need estimates.

Coordination with Burned Area Emergency Response (BAER) and/or Emergency Rehabilitation and Stabilization (ERS) teams is suggested and sometimes necessary to assess the hazards of the burned area and necessary response (Santi et al., 2013).

#### **Assessing Flood and Debris Flow Hazard**

Floods and debris flows both tend to affect relatively low-lying areas, which accumulate and direct the flow of material. Inundation areas and channels should be mapped using topographic maps or digital topographic data (DEMs or LiDAR point clouds). Any historical information on flooding and debris flows along the same drainage or under similar conditions in the region should be reviewed. Locations of alluvial fans and debris fans should be mapped using Google Earth or other internet or printed aerial photographs and topographic data, since these are locations where future debris flows often occur. Many recent fires are quickly evaluated for

debris-flow hazards by the USGS (2020), who produce a series of maps showing expected debris-flow probability, volume, and overall hazard.

### **Consider Expected Sediment Supply and Precipitation**

To evaluate the expected sediment supply for post-wildfire erosion and debris flows, available soil thickness data from consulting reports, soil surveys, and government reports should be considered for severely burned basins. The resistance of hillslope soils to erosion is strongly affected by vegetation removal, so severely burned areas are especially vulnerable. If soil thickness data is not available, borings and geophysical methods can be used to evaluate soil thickness.

Weather records for the region should be reviewed to estimate the likely timing and severity of post-wildfire rainstorms. In anticipation of severe weather events, pre-emptive road/site closures may be necessary, especially in locations near or downstream of severely burned basins.

### **Investigate Potentially Unstable Rock and Soil Slopes**

See Sections 3.19 and 3.20.

## **POSSIBLE MITIGATION OPTIONS**

- Avoidance of burned areas in development
- Early warning systems for local communities
- Pre-emptive road closure within recently burned areas prior to storms
- Road closure or re-alignment
- Surface erosion mitigation, such as reseeding, mulching, straw wattles, log erosion barriers, flood barriers, and water bars (see Section 3.26)
- Debris-flow mitigation, including debris deflectors, sediment barriers, debris retention basins, and debris racks (see Section 3.26)
- Install additional rockfall (Section 3.19) and landslide (Section 3.20) mitigation measures

## **RECOMMENDED AND CITED REFERENCES**

Bradley, J.B., Richards, D.L., Bahner, C.D. 2005. Debris Control Structures – Evaluation and Countermeasures, Hydraulic Engineering Circular 9, 3<sup>rd</sup> Ed. U.S. Department of Transportation, Report No. FHWA-IF-04-016 HEC-9.

Cannon, S. H., and DeGraff, J. 2009. The Increasing Wildfire and Post-Fire Debris-Flow Threat in Western USA, and Implications for Consequences of Climate Change. *In*: K. Sassa & P. Canuti (Eds.) Landslides - Disaster Risk Reduction, pp. 177 - 190. Verlag Berlin Heidelberg: Springer.

Cannon, S. H., and Gartner, J. E. 2005. Wildfire-Related Debris Flow From a Hazards Perspective. *In*: M. Jakob & O. Hungr (Eds.), Debris-flow Hazards and Related Phenomena, pp. 363-385. Berlin Heidelberg: Springer.

Cannon, S. H., Gartner, J. E., Wilson, R. C., Bowers, J. C., and Laber, J. L. 2008. Storm Rainfall Conditions for Floods and Debris Flows from Recently Burned Areas in Southwestern Colorado and Southern California. *Geomorphology*, Vol. 96 (3-4), pp. 250-269, doi: 10.1016/j.geomorph.2007.03.019.

DeBano, L. F., Rice, R.M., and Conrad, C.E. 1979. Soil Heating in Chaparral Fires: effects on soil properties, plant nutrients, erosion, and runoff. U.S. Department of Agriculture; U.S. Forest Service. Research paper PSW-145.

Graber, A. (in press). Integrating Design Parameters for Reseeding and Mulching after Wildfire: A Case Study from the 416 Fire, Colorado. *Environmental and Engineering Geoscience*.

InciWeb, Incident Information System. 2020. Current Incidents. <http://inciweb.nwcg.gov/>.

Kean, J. W., Staley, D. M., & Cannon, S. H. 2011. In Situ Measurements of Post-Fire Debris Flows in Southern California: Comparisons of the Timing and Magnitude of 24 Debris-Flow Events with Rainfall and Soil Moisture Conditions. *Journal of Geophysical Research*, Vol. 116 (F04019), doi: 10.1029/2011jf002005.

National Interagency Fire Center (NIFC). 2020. <http://www.nifc.gov/>.

National Interagency Fire Center (NIFC). 2020. Wildland Fire Open Data. <https://data-nifc.opendata.arcgis.com/>

National Oceanic and Atmospheric Administration (NOAA). 2014. Early Warning Systems Forecast Deadly Mudslides. [http://www.noaa.gov/features/protecting\\_0409/mudslide.html](http://www.noaa.gov/features/protecting_0409/mudslide.html).

Santi, P., Cannon, S., and DeGraff, J. 2013. Wildfire and Landscape Change. In: John F. Shroder (Ed.) *Treatise on Geomorphology*, Vol. 13, pp. 262-287. San Diego: Academic Press.

Santi, P. M., deWolfe, V. G., Higgins, J. D., Cannon, S. H., and Gartner, J. E. 2008. Sources of Debris Flow Material in Burned Areas. *Geomorphology*, Vol. 96 (3-4), pp. 310-321, doi: 10.1016/j.geomorph.2007.02.022.

Staley, D. M., Wasklewicz, T. A., and Kean, J. W. 2014. Characterizing the Primary Material Sources and Dominant Erosional Processes for Post-Fire Debris-Flow Initiation in a Headwater Basin using Multi-Temporal Terrestrial Laser Scanning Data. *Geomorphology*, Vol. 214, pp. 324-338. doi: 10.1016/j.geomorph.2014.02.015.

Swanson, F. J. 1981. Fire and Geomorphic Processes. In H. A. Mooney, T. H. Bonnicksen, N. L. Christensen, J. E. Lotan & W. A. Reiners (Eds.), *Fire Regimes and Ecosystem Properties* (U.S. Department of Agriculture, Forest Service General Technical Report WO-26 ed., pp. 401-420). Washington D.C.

United States Department of Agriculture, Forest Service (USDA FS). 2020. RAVG Home.  
<https://fsapps.nwcg.gov/ravg/>

United States Geological Survey (USGS). 2020. Landslide Hazards Program, Emergency Assessment of Post-Fire Debris-Flow Hazards. Available from:  
[https://landslides.usgs.gov/hazards/postfire\\_debrisflow/](https://landslides.usgs.gov/hazards/postfire_debrisflow/)

Wells, W. G. 1987. The Effects of Fire on the Generation of Debris Flows in Southern California. *Geological Society of America, Reviews in Engineering Geology*. Vol. 7, pp. 105-114. doi: 10.1130/REG7-p105.



**APPENDIX: Spreadsheet of Geologic Hazards and Their Causative and Associative Factors**

GEOLOGIC HAZARD	DOMINANT CAUSATIVE FACTORS		DOMINANT ASSOCIATIVE FACTORS		CAUSATIVE AND ASSOCIATIVE FACTORS					
	Primary	Secondary	Primary	Secondary	Bedrock	Surficial Materials	Topography / Geomorphology	Location	Climate	Site History
Expansive clay soils	Surficial materials	-	Bedrock	Climate	Any (source-rocks are shale/claystone with smectite clay content)	Clay-rich, plastic, smectite clay content	Any	Any	Any (most problematic in arid or semi arid, or seasonal)	Any
Expansive clay bedrock	Bedrock	-	Surficial materials	Climate	Shale/claystone with smectite clay content	Any (Residual soils are clay-rich, plastic, smectite clay content)	Any	Any	Any (most problematic in arid or semi arid, or seasonal)	Any
Heaving bedrock	Bedrock	Surficial materials	Surficial materials	Climate	Interbedded shales, claystone with smectite clay content. Beds of variable swell potential dipping > 30 deg.	< 10 ft. thick (residual soils are often clay-rich, expansive)	Any (steeply-dipping beds may be indicated by parallel ridgelines)	Any	Any (most problematic in arid or semi arid, or seasonal)	Any
Expansive alkali soils	Surficial materials	Climate	Topography / geomorphology	Site history	Any	Soils with SAR ≥ 13	Any (concentrated on slopes above valley floors, flood plains with low water tables)	Any	Semi-arid to arid	Any (commonly associated with irrigated farmland)
Frost action	Climate	Surficial materials	Location	Topography / geomorphology	Any	Silts and clays most susceptible, coarse sands and gravels not susceptible	Any (most common in low-lying land, shallow or flat topography - shallow water table)	More northerly latitudes, and locations at altitude	Snow or polar (significant lengths of time both below and above freezing temperature)	Any
Carbonate karst	Bedrock	-	Topography / geomorphology	Surficial materials	Carbonate rock (limestone, dolomite, marble, chalk)	Any (residual soils are usually rich in clay and chert)	Karst topography (caves, fissures, blind valleys, closed drainages, depressions etc.)	Any	Any (more advanced karst development in warmer and more humid climates)	Any
Evaporite karst	Bedrock	-	Topography / geomorphology	Surficial materials	Evaporite rock (gypsum, anhydrite, halite)	Any (residual soils are usually rich in evaporite minerals)	Any (closed drainages and depressions are indicative)	Any	Any	Any
Subsidence due to underground mining	Location	-	-	-	Any	Any	Any	Regions of underground mining	Any	Any
Subsidence due to fluid withdrawal	Location	-	-	-	Any	Any	Any (often associated with large tectonic basins)	Regions of water/hydrocarbon extraction	Any	Any
Collapsible soils	Surficial materials	Climate	Topography / geomorphology	-	Any (may be sourced from weak sedimentary or evaporite rock)	Sand and silt-rich sediments with clay AND/OR evaporite soils. Uncompacted and dry.	Alluvial fans, debris flow deposits at slope bases; loess deposits on plains and leeward hill slopes	Any	Semi-arid to arid	Previously uncompacted
Organic soils and peat	Surficial materials	Climate	-	-	Any	Soils or sediments with organic content, peat	Any	Any	Temperate or snow (cool and wet)	Any
Sensitive clays	Surficial materials	Site history	-	-	Any (highly sensitive clays are associated with marine deposition - fine sedimentary rocks)	Clays	Any	Any	Any	Previously undisturbed
Permafrost	Climate	-	Location	Topography / geomorphology	Any	Any	Any (high mountain regions in conterminous U.S.)	Almost exclusively Alaska and Canada (northerly latitudes), apart from high mountain regions in conterminous U.S.	Polar (significant lengths of time below freezing)	Any

<b>Saline Soils</b>	Surficial materials	Climate	Topography / geomorphology	Bedrock	Any (may be sourced from anhydrite or halite)	Salt-bearing soils	Any (concentrated in low-lying areas, bases of slopes, valley floors, floodplains)	Any (commonly associated with land near to the coast)	Semi-arid to arid	Any (commonly associated with irrigated farmland)
<b>Gypsiferous Soils</b>	Surficial materials	Climate	Bedrock	Topography / geomorphology	Any (source-rock is gypsum)	Gypsiferous soils	Any (concentrated in low-lying areas, bases of slopes, valley floors, floodplains)	Any	Semi-arid to arid	Any
<b>Sulfate soils</b>	Surficial materials	Climate	Topography / geomorphology	Bedrock	Any (may be sourced from gypsum or pyrite-bearing rock)	Sulfate-bearing soils (gypsiferous, pyritic or from other source)	Any (concentrated in low-lying areas, bases of slopes, valley floors, floodplains)	Any	Semi-arid to arid (wet and humid climates forces sulfates to deeper strata)	Any (fertilizers and industrial effluents contribute)
<b>Acid sulfate soils</b>	Surficial materials	Topography / geomorphology	Location	-	Any (may be sourced from pyrite-bearing rock)	soils containing pyrite, waterlogged or shallow water table	Low-lying, waterlogged coastal areas (estuaries, salt marshes, swamps)	Coastal areas (brine groundwater)	Any	Any
<b>Sulfide rock</b>	Bedrock	-	Location	Site history	Pyrite-bearing (carbonaceous shales, argillaceous rocks from anoxic depositional env.. Igneous rock, coal and metal-ore deposits)	Any	Any	Any (associated with regions of coal or metal-ore mining)	Any (more rapid weathering in warmer and wetter climates)	Any (commonly associated with coal or metal-ore mines)
<b>Sulfide mine tailings</b>	Surficial materials	-	Site History	Location	Any	Mine tailings from coal or metal-ore mines	Any	Regions of coal or metal-ore mining	Any (more rapid weathering in warmer and wetter climates)	Mine tailings dump
<b>Unstable rock slopes</b>	Topography / geomorphology	Surficial materials	Climate	-	Any	Exposures of rock	Slopes	Any	Any (slope movements may be more common in wet or seasonal climates)	Any
<b>Unstable soil slopes</b>	Topography / geomorphology	Surficial materials	Climate	-	Any	Soil	Slopes	Any	Any (slope movements may be more common in wet or seasonal climates)	Any
<b>Unstable shale slopes</b>	Topography / geomorphology	Surficial materials	Climate	-	Shale; interbedded shale	Exposures of shale	Slopes	Any	Any (slope movements may be more common in wet or seasonal climates)	Any
<b>Talus</b>	Surficial materials	-	Topography / geomorphology	Location	Any	Talus	Slopes and slope-bases beneath rock outcrops	Any (most common in mountainous regions)	Any	Any
<b>Seismic activity</b>	Location	-	-	-	Any	Any	Any	Regions of seismic activity	Any	Any
<b>Active volcanic hazards</b>	Location	-	-	-	Any	Any	Any	Areas close to active volcanoes	Any	Any
<b>Volcanic terrain hazards</b>	Bedrock / Surficial materials	Topography / geomorphology	Location	-	Extrusive igneous rocks (basalt, andesite, rhyolite)	Bentonite clays (weathered volcanic ash)	Any	Areas of historic volcanic activity	Any	Any
<b>Surface Water Hazards</b>	Climate	-	Topography / geomorphology	-	Any	Any	Flood plains, valleys, canyons	Any	Any climate with periods of intense rainfall. (producing excess surface water)	Any
<b>Coastal hazards</b>	Location	-	-	-	Any	Any	Any	Coastal regions	Any	Any
<b>Naturally occurring asbestos</b>	Bedrock	Surficial materials	Location	-	Ultramafic host rocks (eg. serpentinite)	Serpentine soils (magnesium-rich; calcium, potassium, phosphorous-poor)	Any	Asbestos known to occur in Eastern and southwestern US (have asbestos maps)	Any	Any
<b>Wildfire burn areas</b>	Fire (not represented elsewhere on chart)	-	Site History	Location	Any	Any	Any	Any location with significant vegetation, especially in arid or semi-arid climates	Any	History of recent wildfire on-site or upstream

### Summary of Flow Chart Outcomes

Section	Hazard	Flow Chart Outcomes				
		Flow Chart 1	Flow Chart 2	Flow Chart 3	Flow Chart 4	Flow Chart 5
		Bedrock	Surficial Materials	Topography and Geomorphology	Location	Climate
3.1	Expansive clay soils					
	Expansive clay bedrock					
3.2	Heaving bedrock					
3.3	Expansive alkali soils					
3.4	Frost action					
3.5	Carbonate karst					
3.6	Evaporite karst					
3.7	Subsidence due to underground mining					
3.8	Subsidence due to fluid withdrawal					
3.9	Collapsible soils					
3.10	Organic soils and peat					
3.11	Sensitive clays					
3.12	Permafrost					
3.13	Saline Soils					
3.14	Gypsiferous Soils					
3.15	Sulfate soils					
3.16	Acid sulfate soils					
3.17	Sulfide rock					
3.18	Sulfide mine tailings					
3.19	Unstable rock slopes					
3.20	Unstable soil slopes					
3.21	Unstable shale slopes					
3.22	Talus					
3.23	Seismic hazards					
3.24	Active volcanic hazards					
3.25	Volcanic terrain hazards					
3.26	Surface water hazards					
3.27	Coastal hazards					
3.28	Naturally occurring asbestos					
3.29	Wildfire burn areas					